

2N7001T-Q1 Single-bit 双电源缓冲电压信号转换器

1 特性

- 在 1.65V 至 3.6 V 范围内进行上行和下行电平转换
- 符合 AEC-Q100 汽车标准
- 工作温度等级 1：-40°C 至 +125°C
- 最大静态电流 ($I_{CCA} + I_{CCB}$) 14 μ A (最高 125°C)
- 在整个电源范围内支持高达 100Mbps 的速率
- V_{CC} 隔离特性
 - 如果任何一个 V_{CC} 输入低于 100mV，则输出处于高阻态
- I_{off} 支持局部断电模式运行
- 闩锁性能超过 100mA，符合 JESD 78 II 类规范
- ESD 保护性能超过 JEDEC JS-001 规范要求
 - 2000V 人体放电模型
 - 1000V 充电器件模型

2 应用

- MCU/FPGA/处理器 GPIO 转换
- 通信模块至处理器转换
- 推挽式 I/O 缓冲

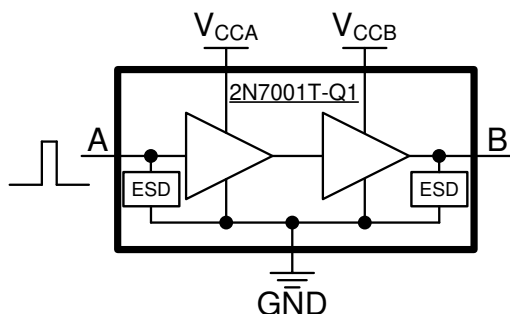

方框图和引脚配置

3 说明

2N7001T-Q1 器件符合 AEC-Q100 标准，是一款采用两个独立可配置电源轨的 single-bit 缓冲电压信号转换器，可对单向信号进行升压/降压转换。该器件通过 1.65V 至 3.60V 的 V_{CCA} 和 V_{CCB} 电源供电。 V_{CCA} 定义了 A 输入端的输入阈值电压。 V_{CCB} 定义了 B 输出端的输出驱动电压。

该器件完全符合使用 I_{off} 电流的部分断电应用的规范要求。当器件断电时， I_{off} 保护电路可确保不从输入、输出或偏置到特定电压的组合 I/O 获取多余电流，也不向其提供多余电流。

V_{CC} 隔离功能确保当 V_{CCA} 或 V_{CCB} 低于 100mV 时，输出端口 (B) 进入高阻态。

器件信息⁽¹⁾

器件型号	封装	封装尺寸 (标称值)
2N7001TDCKRQ1	SC70 (5)	2.00mm × 1.25mm

(1) 如需了解所有可用封装，请参阅数据表末尾的可订购产品附录。

DCK Package

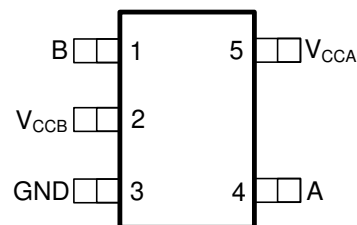

Table of Contents

1 特性	1	8.3 Feature Description.....	10
2 应用	1	8.4 Device Functional Modes.....	11
3 说明	1	9 Application and Implementation	12
4 Revision History	2	9.1 Application Information.....	12
5 Pin Configuration and Functions	3	9.2 Typical Applications.....	12
6 Specifications	4	10 Power Supply Recommendations	14
6.1 Absolute Maximum Ratings.....	4	11 Layout	14
6.2 ESD Ratings.....	4	11.1 Layout Guidelines.....	14
6.3 Recommended Operating Conditions.....	5	11.2 Layout Example.....	14
6.4 Thermal Information.....	5	12 Device and Documentation Support	15
6.5 Electrical Characteristics.....	6	12.1 Documentation Support.....	15
6.6 Switching Characteristics.....	6	12.2 Receiving Notification of Documentation Updates..	15
6.7 Operating Characteristics: $T_A = 25^\circ\text{C}$	6	12.3 Support Resources.....	15
6.8 Typical Characteristics.....	8	12.4 Trademarks.....	15
7 Parameter Measurement Information	9	12.5 Electrostatic Discharge Caution.....	15
7.1 Load Circuit and Voltage Waveforms.....	9	12.6 Glossary.....	15
8 Detailed Description	10	13 Mechanical, Packaging, and Orderable Information	15
8.1 Overview.....	10		
8.2 Functional Block Diagram.....	10		

4 Revision History

注：以前版本的页码可能与当前版本的页码不同

Changes from Revision * (February 2020) to Revision A (July 2020)	Page
• 将器件状态从“预告信息”更改为“量产数据”	1

5 Pin Configuration and Functions



图 5-1. DCK Package 5-Pin SC70 Top View

Pin Functions

PIN		TYPE	DESCRIPTION
NAME	DCK		
B	1	O	Data Output. This pin is referenced to V _{CCB} .
V _{CCB}	2	—	Output Supply voltage. $1.65\text{V} \leq V_{CCB} \leq 3.6\text{ V}$.
GND	3	—	Ground
A	4	I	Data Input. This pin is referenced to V _{CCA} .
V _{CCA}	5	—	Input Supply voltage. $1.65\text{V} \leq V_{CCA} \leq 3.6\text{ V}$.

6 Specifications

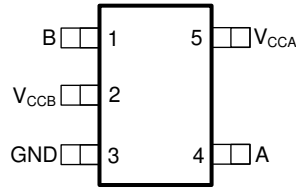
6.1 Absolute Maximum Ratings

over operating free-air temperature range (unless otherwise noted)⁽¹⁾

		MIN	MAX	UNIT
V _{CCA}	Supply voltage	- 0.5	4.2	V
V _{CCB}		- 0.5	4.2	V
V _I	Input voltage ⁽²⁾	- 0.5	4.2	V
V _O	Voltage range applied to any output in the high-impedance or power-off state ⁽²⁾	- 0.5	4.2	V
V _O	Voltage range applied to any output in the high or low state ^{(2) (3)}	- 0.5	V _{CCB} + 0.2	V
I _{IK}	Input clamp current		- 50	mA
I _{OK}	Output clamp current		- 50	
I _O	Continuous output current	- 50	50	mA
I _{CC}	Continuous output current through V _{CCA} , V _{CCB} , or GND	- 100	100	mA
T _J	Junction temperature	- 40	150	°C
T _{stg}	Storage temperature	- 65	150	°C

- (1) Stresses beyond those listed under *Absolute Maximum Rating* may cause permanent damage to the device. These are stress ratings only, which do not imply functional operation of the device at these or any other conditions beyond those indicated under *Recommended Operating Condition*. Exposure to absolute-maximum-rated conditions for extended periods may affect device reliability.
- (2) The input and output voltage ratings may be exceeded if the input and output current ratings are observed.
- (3) The output positive-voltage rating may be exceeded up to 4.2V maximum if the output current ratings are observed.

6.2 ESD Ratings

		VALUE	UNIT
V _(ESD)	Electrostatic discharge	Human body model (HBM), per AEC Q100-002 ⁽¹⁾	V
		Charged device model (CDM), per AEC Q100-011	

- (1) AEC Q100-002 indicate that HBM stressing shall be in accordance with the ANSI/ESDA/JEDEC JS-001 specification.

6.3 Recommended Operating Conditions

over operating free-air temperature range (unless otherwise noted)

		MIN	MAX	UNIT
V _{CCA}	Supply voltage	1.65	3.6	V
V _{CCB}	Supply voltage	1.65	3.6	V
V _{IH}	High-level input voltage	V _{CCA} = 1.65 V - 1.95V	V _{CCA} × 0.65	
		V _{CCA} = 2.30 V - 2.70V	1.6	
		V _{CCA} = 3.00 V - 3.60V	2.0	
V _{IL}	Low-level input voltage	V _{CCA} = 1.65 V - 1.95V	V _{CCA} × 0.35	
		V _{CCA} = 2.30 V - 2.70V	0.7	
		V _{CCA} = 3.00 V - 3.60V	0.8	
V _I	Input voltage	0	3.6	V
V _O	Output voltage	Active State	0	V _{CCB}
		Tri-State	0	3.6
Δt/Δv	Input transition rise and fall rate		100	ns/V
T _A	Operating free-air temperature	-40	125	°C

6.4 Thermal Information

THERMAL METRIC ⁽¹⁾		2N7001T-Q1	UNIT
		DCK (SC70)	
		5 PINS	
R _{θJA}	Junction-to-ambient thermal resistance	253.5	°C/W
R _{θJC(top)}	Junction-to-case (top) thermal resistance	162.6	°C/W
R _{θJB}	Junction-to-board thermal resistance	140.6	°C/W
Ψ _{JT}	Junction-to-top characterization parameter	69.8	°C/W
Ψ _{JB}	Junction-to-board characterization parameter	139.7	°C/W
R _{θJC(bot)}	Junction-to-case (bottom) thermal resistance	NA	°C/W

- (1) For more information about traditional and new thermal metrics, see the [Semiconductor and IC Package Thermal Metrics](#) application report.

6.5 Electrical Characteristics

over operating free-air temperature range (unless otherwise noted)

PARAMETER		TEST CONDITIONS	V _{CCA}	V _{CCB}	MIN	TYP	MAX	UNIT
V _{OH}	High Level Output Voltage	V _I = V _{IH}	I _{OH} = -100 μA	1.65 V - 3.6 V	1.65 V - 3.6 V	V _{CCB} -0.1		V
			I _{OH} = -8 mA	1.65 V	1.65 V	1.2		
			I _{OH} = -9 mA	2.30 V	2.30 V	1.75		
			I _{OH} = -12 mA	3.00 V	3.00 V	2.3		
V _{OL}	Low Level Output Voltage	V _I = V _{IL}	I _{OL} = 100 μA	1.65 V - 3.6 V	1.65 V - 3.6 V	0.1		V
			I _{OL} = 8 mA	1.65 V	1.65 V	0.45		
			I _{OL} = 9 mA	2.30 V	2.30 V	0.55		
			I _{OL} = 12 mA	3.00 V	3.00 V	0.7		
I _{off}	Partial power down current	V _I or V _O = 0 V - 3.6 V	0 V	0 V - 3.6 V	- 8		8	μA
		V _I or V _O = 0 V - 3.6 V	0 V - 3.6 V	0 V	- 8			
I _{CCA}	V _{CCA} Supply Current	V _I = V _{CCA} or GND; I _o = 0 mA	1.65 V - 3.6 V	1.65 V - 3.6 V	8		μA	
			0 V	3.60 V	- 8			
			3.60 V	0 V	8			
I _{CCB}	V _{CCB} Supply Current	V _I = V _{CCA} or GND; I _o = 0 mA	1.65 V - 3.6 V	1.65 V - 3.6 V	8		μA	
			0 V	3.60 V	8			
			3.60 V	0 V	- 8			
I _{CCA} + I _{CCB}	Combined Supply Current	V _I = V _{CCA} or GND; I _o = 0 mA	1.65 V - 3.6 V	1.65 V - 3.6 V	14		μA	
C _I	Input Capacitance	V _I = 1.65V DC + 1 MHz, -16 dBm sine wave	3.30V	0V	2		pF	
C _O	Output Capacitance	V _O = 1.65V DC + 1 MHz, -16 dBm sine wave	0V	3.30V	4		pF	

6.6 Switching Characteristics

over operating free-air temperature range (unless otherwise noted)

PARAMETER		V _{CCA}	V _{CCB}	MIN	MAX	UNIT
t _{pd}	Propagation delay	1.65 V - 1.95 V	1.65 V - 1.95 V	0.5	20	ns
			2.30 V - 2.70 V	0.5	17	ns
			3.00 V - 3.60 V	0.5	14	ns
		2.30 V - 2.70 V	1.65 V - 1.95 V	0.5	18	ns
			2.30 V - 2.70 V	0.5	15	ns
			3.00 V - 3.60 V	0.5	12	ns
		3.00 V - 3.60 V	1.65 V - 1.95 V	0.5	16	ns
			2.30 V - 2.70 V	0.5	13	ns
			3.00 V - 3.60 V	0.5	10	ns

6.7 Operating Characteristics: T_A = 25°C

PARAMETER	TEST CONDITIONS	MIN	TYP	MAX	UNIT
C _{pdA}	I _o = 0 mA, C _L = 0 pF, f = 1 MHz t _r = t _f = 1 ns	V _{CCA} = V _{CCB} = 1.8 V	1		pF
		V _{CCA} = V _{CCB} = 2.5 V	1.3		
		V _{CCA} = V _{CCB} = 3.3 V	1.8		

PARAMETER		TEST CONDITIONS		MIN	TYP	MAX	UNIT
C _{pdB}	Power Dissipation Capacitance - Port B	I _O = 0 mA, C _L = 0 pF, f = 1 MHz t _r = t _f = 1 ns	V _{CCA} = V _{CCB} = 1.8 V		12		pF
			V _{CCA} = V _{CCB} = 2.5 V		15		
			V _{CCA} = V _{CCB} = 3.3 V		18		

6.8 Typical Characteristics

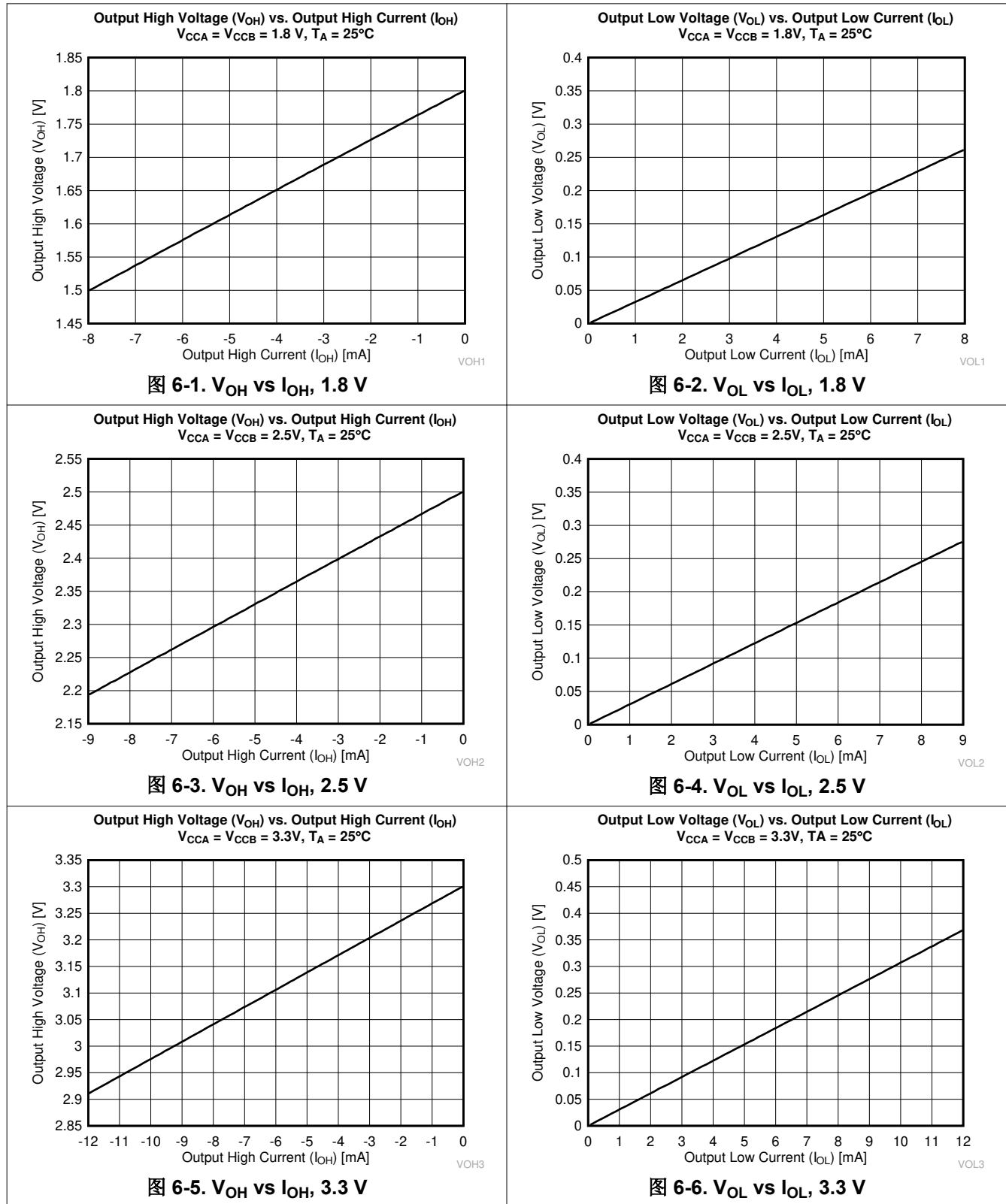

7 Parameter Measurement Information

7.1 Load Circuit and Voltage Waveforms

Unless otherwise noted, all input pulses are supplied by generators having the following characteristics:

- $f = 1 \text{ MHz}$
- $Z_O = 50 \ \Omega$
- $dv/dt \leq 1 \text{ ns/V}$

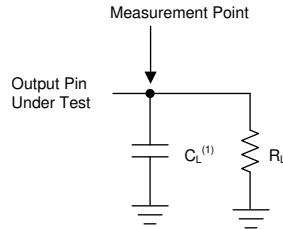

A. C_L includes probe and jig capacitance.

图 7-1. Load Circuit

表 7-1. Load Circuit Conditions

Parameter	V_{CC}	R_L	C_L
t_{pd} Propagation (delay) time	1.65 V - 3.6 V	2 k Ω	15 pF

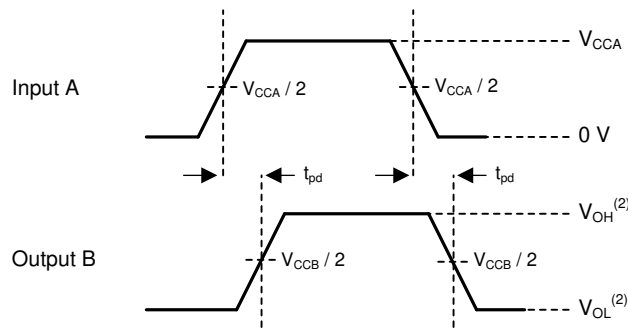

- A. V_{CCI} is the supply pin associated with the input port.
 B. V_{OH} and V_{OL} are typical output voltage levels that occur with specified R_L and C_L .

图 7-2. Propagation Delay

8 Detailed Description

8.1 Overview

The 2N7001T-Q1 is an automotive AEC-Q100 qualified single-bit dual-supply buffered voltage signal converter that can be used to up or down-translate a single unidirectional signal. The device is operational with both V_{CCA} and V_{CCB} supplies down to 1.65 V and up to 3.60 V. V_{CCA} defines the input threshold voltage on the A input while V_{CCB} defines the output voltage on the B output.

8.2 Functional Block Diagram

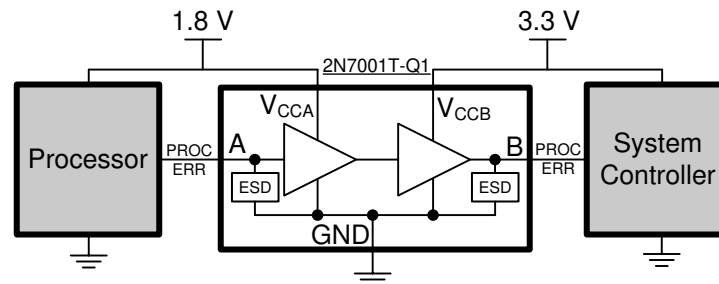

8.3 Feature Description

8.3.1 Up-Translation or Down-Translation from 1.65 V to 3.60 V

The V_{CCA} and V_{CCB} pins can both be supplied by a voltage range from 1.65 V to 3.6 V. This voltage range makes the device suitable for translating between any of the voltage nodes (1.8 V, 2.5 V, and 3.3 V).

8.3.2 Balanced CMOS Push-Pull Outputs

A balanced output allows the device to sink and source similar currents. The drive capability of this device may create fast edges into light loads, so routing and load conditions should be considered to prevent ringing. Additionally, the outputs of this device are capable of driving larger currents than the device can sustain without being damaged. It is important for the output power of the device to be limited to avoid damage due to over-current. The electrical and thermal limits defined in the [Absolute Maximum Ratings](#) must be followed at all times.

8.3.3 Standard CMOS Inputs

Standard CMOS inputs are high impedance and are typically modeled as a resistor in parallel with the input capacitance shown in the [Electrical Characteristics](#). The worst case resistance is calculated with the maximum input voltage, shown in the [Absolute Maximum Ratings](#), and the maximum input leakage current, shown in the [Electrical Characteristics](#), using Ohm's law ($R = V \div I$).

Signals applied to the inputs need to have fast edge rates, as defined by $\Delta t / \Delta v$ in the [Recommended Operating Conditions](#) to avoid excessive current consumption and oscillations. If a slow or noisy input signal is required, a device with a Schmitt-trigger input should be used to condition the input signal prior to the standard CMOS input.

8.3.4 Negative Clamping Diodes

The inputs and outputs to this device have negative clamping diodes as shown in 图 8-1.

CAUTION

Voltages beyond the values specified in the *Absolute Maximum Ratings* table can cause damage to the device. The input negative-voltage and output voltage ratings may be exceeded if the input and output clamp-current ratings are observed.



图 8-1. Electrical Placement of Clamping Diodes for Each Input and Output

8.3.5 Partial Power Down (I_{off})

The inputs and outputs for this device enter a high-impedance state when the supply voltage is 0 V. The maximum leakage into or out of any input pin or output pin on the device is specified by I_{off} in the *Electrical Characteristics*.

8.3.6 Over-voltage Tolerant Inputs

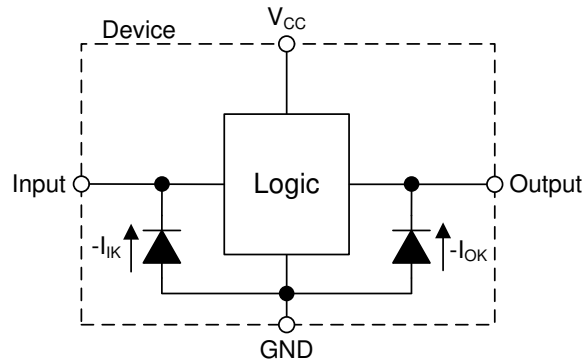
Input signals to this device can be driven above the input supply voltage (V_{CCA}), as long as they remain below the maximum input voltage value specified in the *Recommended Operating Conditions*.

8.4 Device Functional Modes

表 8-1 lists the functional modes of the 2N7001T-Q1 device.

表 8-1. Function Table

INPUT	OUTPUT
L (Referenced to V_{CCA})	L (Referenced to V_{CCB})
H (Referenced to V_{CCA})	H (Referenced to V_{CCB})

9 Application and Implementation

Note

以下应用部分的信息不属于 TI 组件规范，TI 不担保其准确性和完整性。客户应负责确定 TI 组件是否适用于其应用。客户应验证并测试其设计，以确保系统功能。

9.1 Application Information

The 2N7001T-Q1 device can be used in level-translation applications for interfacing between devices or systems that are operating at different interface voltages.

9.2 Typical Applications

9.2.1 Processor Error Up Translation

图 9-1 shows an example of the 2N7001T-Q1 being used in a unidirectional logic level-shifting application.



图 9-1. Processor Error Up Translation Application

9.2.1.1 Design Requirements

For this design example, use the parameters shown in 表 9-1.

表 9-1. Design Parameters

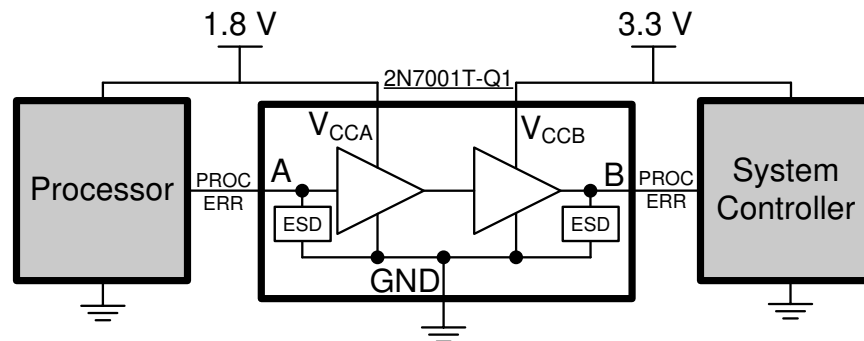
DESIGN PARAMETER	EXAMPLE VALUE
Input voltage supply	1.8 V
Output voltage supply	3.3 V

9.2.1.2 Detailed Design Procedure

To begin the design process, determine the following:

- Input voltage range
 - The supply voltage of the upstream device (device that is driving input pin A) will determine the appropriate input voltage range. For a valid logic-high, the value must exceed the high-level input voltage (V_{IH}) of the input port. For a valid logic low the value must be less than the low-level input voltage (V_{IL}) of the input port.
- Output voltage range
 - The supply voltage of the downstream device (device that output pin B is driving) will determine the appropriate output voltage range.

9.2.1.3 Application Curve



图 9-2. Up Translation (1.8 V to 3.3 V) at 1 MHz

9.2.2 Discrete FET Translation Replacement

The 2N7001T-Q1 device is an excellent option for replacing discrete translators, as shown in 图 9-3, and has the following benefits regarding discrete translation implementations:

- A single device vs a four component solution
- Minimized implementation size
- Lower power consumption
- V_{CC} isolation feature
- Higher data rates
- Integrated ESD protection
- Improved glitch performance

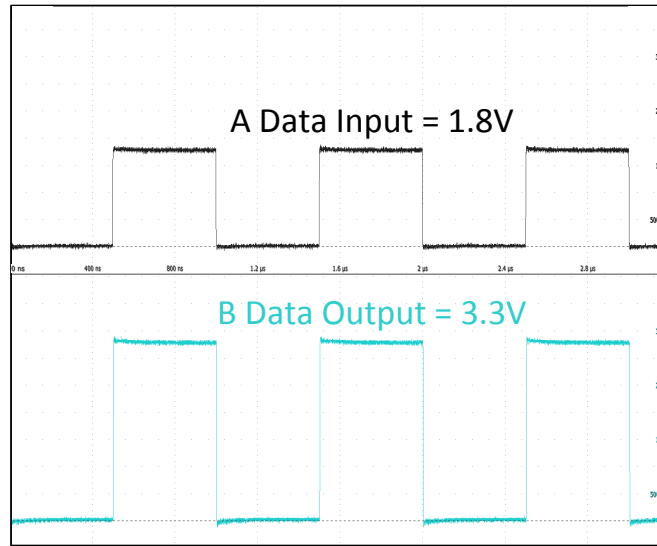
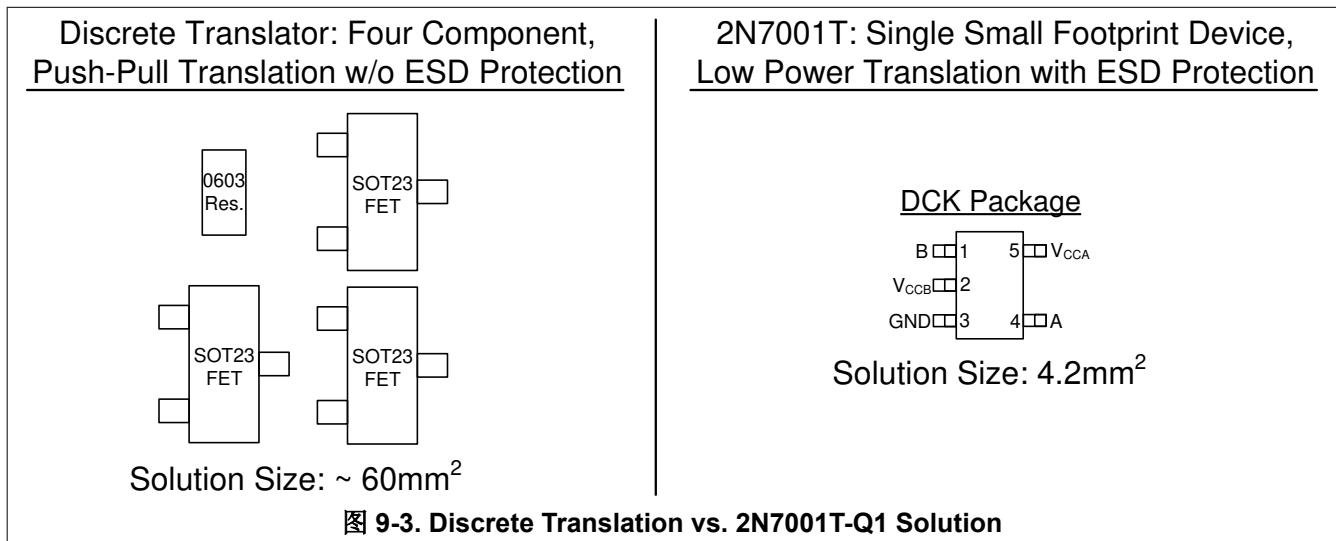

10 Power Supply Recommendations

The 2N7001T-Q1 device uses two separate configurable power-supply rails, V_{CCA} and V_{CCB} . The V_{CCA} and V_{CCB} power-supply rails accept any supply voltage that range from 1.65 V to 3.6 V. The A input and B output are referenced to V_{CCA} and V_{CCB} respectively allowing up or down translation among the 1.8-V, 2.5-V, and 3.3-V voltage nodes. A 0.1 μF bypass capacitor is recommended on all V_{CC} pins.

Always apply a ground reference to the GND pin first. However, there are no additional requirement for power supply sequencing.

11 Layout

11.1 Layout Guidelines

To ensure reliability of the device, following common printed-circuit board layout guidelines are recommended:

- Use bypass capacitors on the power supply pins and place them as close to the device as possible. A 0.1 μF capacitor is recommended, but transient performance can be improved by having both 1 μF and 0.1 μF capacitors in parallel as bypass capacitors.
- Use short trace lengths to avoid excessive loading.

11.2 Layout Example



图 11-1. DCK Package Example Layout

12 Device and Documentation Support

12.1 Documentation Support

12.1.1 Related Documentation

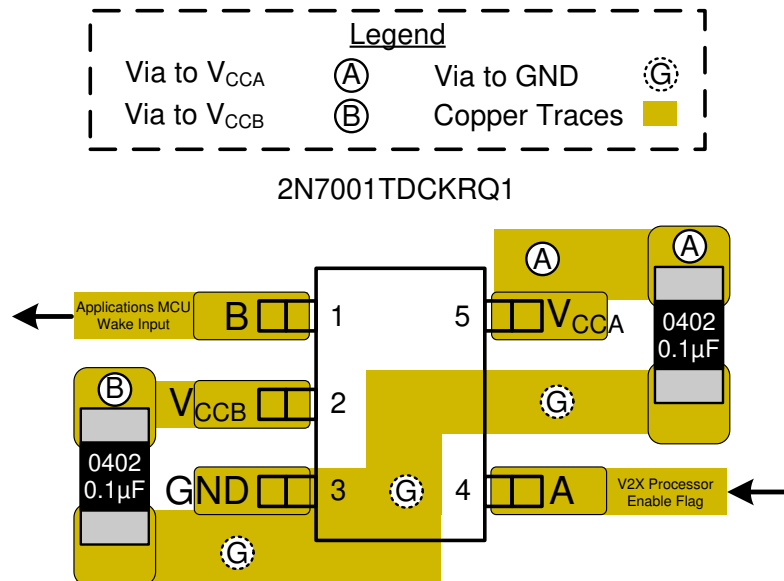
For related documentation see the following:

- Texas Instruments, [Common Risks with FET Translation and Advantages of 2N7001T](#) application report
- Texas Instruments, [Implications of Slow or Floating CMOS Inputs](#) application report
- Texas Instruments, [Designing and Manufacturing with TI's X2SON Packages](#) application report

12.2 Receiving Notification of Documentation Updates

To receive notification of documentation updates, navigate to the device product folder on [ti.com](#). Click on *Subscribe to updates* to register and receive a weekly digest of any product information that has changed. For change details, review the revision history included in any revised document.

12.3 Support Resources

[TI E2E™ support forums](#) are an engineer's go-to source for fast, verified answers and design help — straight from the experts. Search existing answers or ask your own question to get the quick design help you need.

Linked content is provided "AS IS" by the respective contributors. They do not constitute TI specifications and do not necessarily reflect TI's views; see TI's [Terms of Use](#).

12.4 Trademarks

TI E2E™ is a trademark of Texas Instruments.

所有商标均为其各自所有者的财产。

12.5 Electrostatic Discharge Caution



This integrated circuit can be damaged by ESD. Texas Instruments recommends that all integrated circuits be handled with appropriate precautions. Failure to observe proper handling and installation procedures can cause damage.

ESD damage can range from subtle performance degradation to complete device failure. Precision integrated circuits may be more susceptible to damage because very small parametric changes could cause the device not to meet its published specifications.

12.6 Glossary

[TI Glossary](#) This glossary lists and explains terms, acronyms, and definitions.

13 Mechanical, Packaging, and Orderable Information

The following pages include mechanical, packaging, and orderable information. This information is the most current data available for the designated devices. This data is subject to change without notice and revision of this document. For browser-based versions of this data sheet, refer to the left-hand navigation.

PACKAGING INFORMATION

Orderable Device	Status (1)	Package Type	Package Drawing	Pins	Package Qty	Eco Plan (2)	Lead finish/ Ball material (6)	MSL Peak Temp (3)	Op Temp (°C)	Device Marking (4/5)	Samples
2N7001TQDCKRQ1	ACTIVE	SC70	DCK	5	3000	RoHS & Green	SN	Level-1-260C-UNLIM	-40 to 125	W9	Samples

(1) The marketing status values are defined as follows:

ACTIVE: Product device recommended for new designs.

LIFEBUY: TI has announced that the device will be discontinued, and a lifetime-buy period is in effect.

NRND: Not recommended for new designs. Device is in production to support existing customers, but TI does not recommend using this part in a new design.

PREVIEW: Device has been announced but is not in production. Samples may or may not be available.

OBSOLETE: TI has discontinued the production of the device.

(2) **RoHS:** TI defines "RoHS" to mean semiconductor products that are compliant with the current EU RoHS requirements for all 10 RoHS substances, including the requirement that RoHS substance do not exceed 0.1% by weight in homogeneous materials. Where designed to be soldered at high temperatures, "RoHS" products are suitable for use in specified lead-free processes. TI may reference these types of products as "Pb-Free".

RoHS Exempt: TI defines "RoHS Exempt" to mean products that contain lead but are compliant with EU RoHS pursuant to a specific EU RoHS exemption.

Green: TI defines "Green" to mean the content of Chlorine (Cl) and Bromine (Br) based flame retardants meet JS709B low halogen requirements of <=1000ppm threshold. Antimony trioxide based flame retardants must also meet the <=1000ppm threshold requirement.

(3) MSL, Peak Temp. - The Moisture Sensitivity Level rating according to the JEDEC industry standard classifications, and peak solder temperature.

(4) There may be additional marking, which relates to the logo, the lot trace code information, or the environmental category on the device.

(5) Multiple Device Markings will be inside parentheses. Only one Device Marking contained in parentheses and separated by a "-" will appear on a device. If a line is indented then it is a continuation of the previous line and the two combined represent the entire Device Marking for that device.

(6) Lead finish/Ball material - Orderable Devices may have multiple material finish options. Finish options are separated by a vertical ruled line. Lead finish/Ball material values may wrap to two lines if the finish value exceeds the maximum column width.

Important Information and Disclaimer:The information provided on this page represents TI's knowledge and belief as of the date that it is provided. TI bases its knowledge and belief on information provided by third parties, and makes no representation or warranty as to the accuracy of such information. Efforts are underway to better integrate information from third parties. TI has taken and continues to take reasonable steps to provide representative and accurate information but may not have conducted destructive testing or chemical analysis on incoming materials and chemicals. TI and TI suppliers consider certain information to be proprietary, and thus CAS numbers and other limited information may not be available for release.

In no event shall TI's liability arising out of such information exceed the total purchase price of the TI part(s) at issue in this document sold by TI to Customer on an annual basis.

TAPE AND REEL INFORMATION

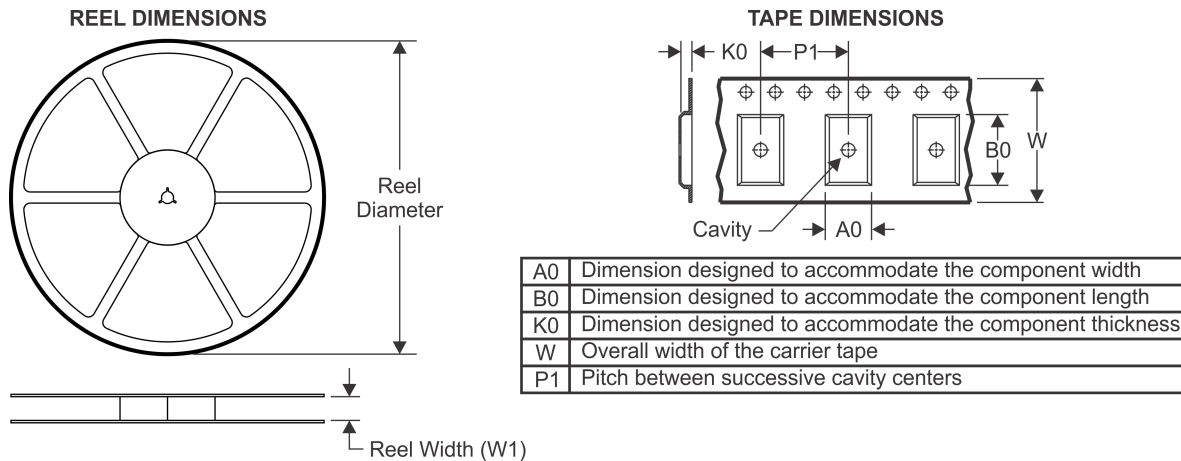

QUADRANT ASSIGNMENTS FOR PIN 1 ORIENTATION IN TAPE



*All dimensions are nominal

Device	Package Type	Package Drawing	Pins	SPQ	Reel Diameter (mm)	Reel Width W1 (mm)	A0 (mm)	B0 (mm)	K0 (mm)	P1 (mm)	W (mm)	Pin1 Quadrant
2N7001TQDCKRQ1	SC70	DCK	5	3000	178.0	9.0	2.4	2.5	1.2	4.0	8.0	Q3

TAPE AND REEL BOX DIMENSIONS

*All dimensions are nominal

Device	Package Type	Package Drawing	Pins	SPQ	Length (mm)	Width (mm)	Height (mm)
2N7001TQDCKRQ1	SC70	DCK	5	3000	180.0	180.0	18.0

DCK0005A



PACKAGE OUTLINE

SOT - 1.1 max height

SMALL OUTLINE TRANSISTOR

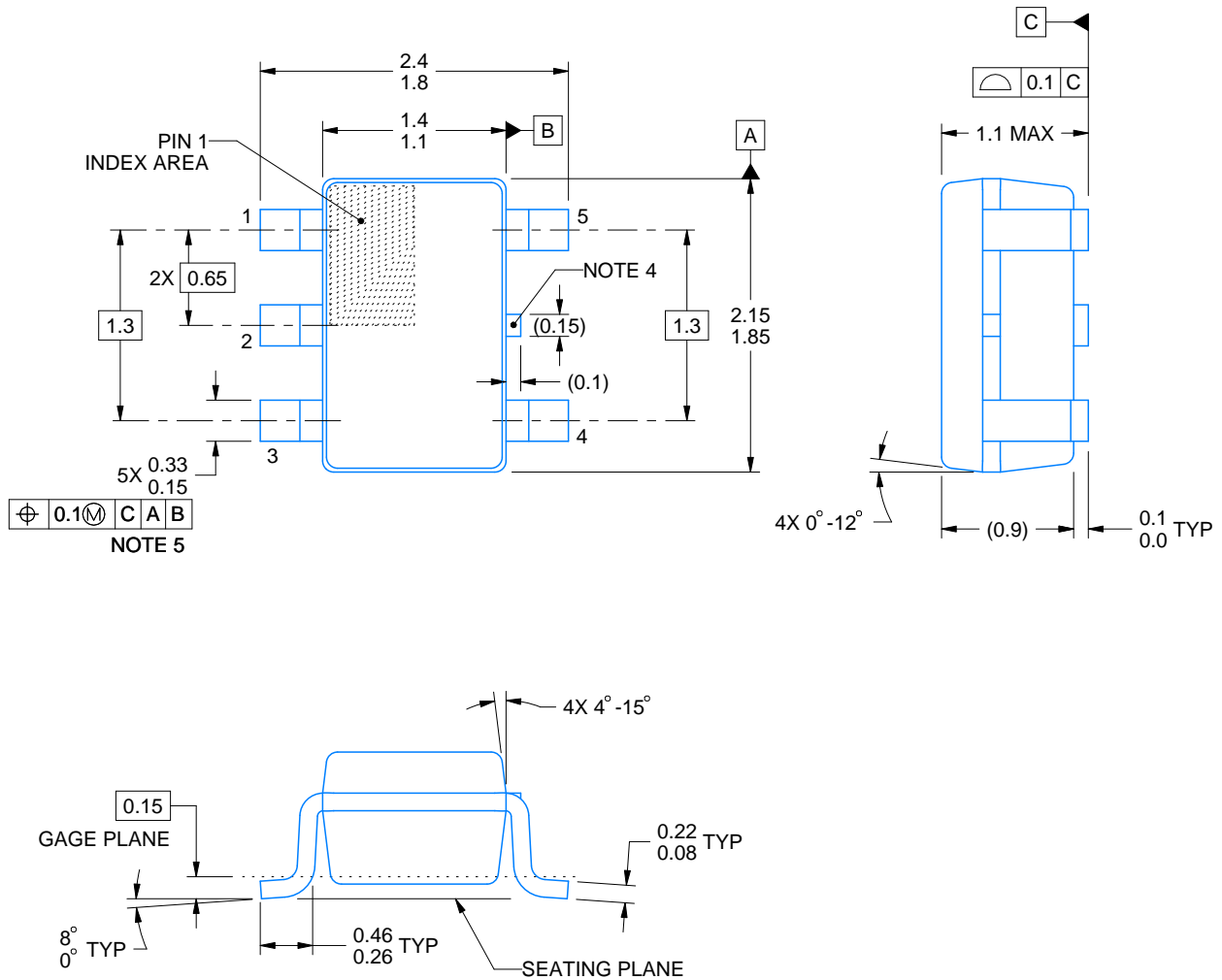

4214834/G 11/2024

NOTES:

1. All linear dimensions are in millimeters. Any dimensions in parenthesis are for reference only. Dimensioning and tolerancing per ASME Y14.5M.
2. This drawing is subject to change without notice.
3. Reference JEDEC MO-203.
4. Support pin may differ or may not be present.
5. Lead width does not comply with JEDEC.
6. Body dimensions do not include mold flash, protrusions, or gate burrs. Mold flash, protrusions, or gate burrs shall not exceed 0.25mm per side

EXAMPLE BOARD LAYOUT

DCK0005A

SOT - 1.1 max height

SMALL OUTLINE TRANSISTOR

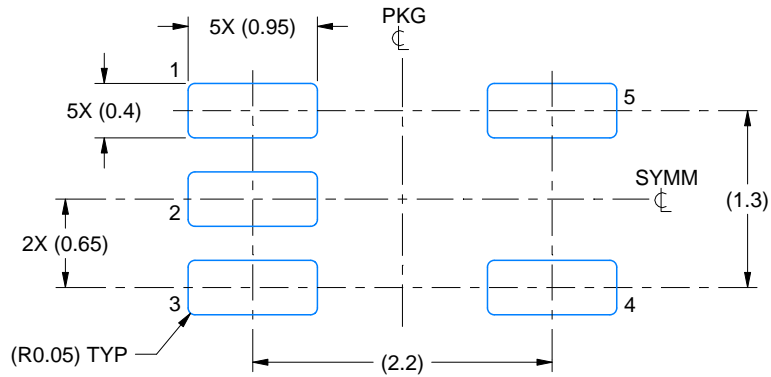

LAND PATTERN EXAMPLE
EXPOSED METAL SHOWN
SCALE:18X

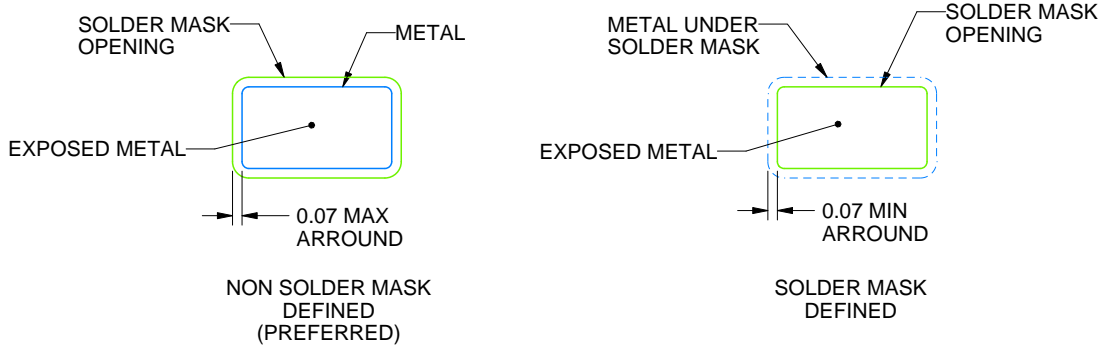

SOLDER MASK DETAILS

4214834/G 11/2024

NOTES: (continued)

- 7. Publication IPC-7351 may have alternate designs.
- 8. Solder mask tolerances between and around signal pads can vary based on board fabrication site.

EXAMPLE STENCIL DESIGN

DCK0005A

SOT - 1.1 max height

SMALL OUTLINE TRANSISTOR

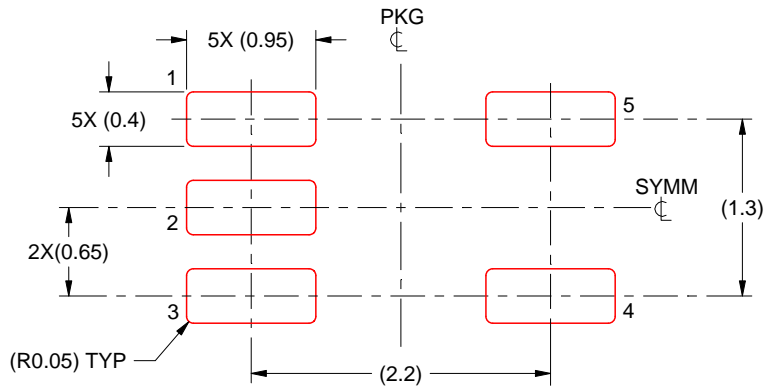

SOLDER PASTE EXAMPLE
BASED ON 0.125 THICK STENCIL
SCALE:18X

4214834/G 11/2024

NOTES: (continued)

9. Laser cutting apertures with trapezoidal walls and rounded corners may offer better paste release. IPC-7525 may have alternate design recommendations.
10. Board assembly site may have different recommendations for stencil design.

重要通知和免责声明

TI“按原样”提供技术和可靠性数据（包括数据表）、设计资源（包括参考设计）、应用或其他设计建议、网络工具、安全信息和其他资源，不保证没有瑕疵且不做任何明示或暗示的担保，包括但不限于对适销性、某特定用途方面的适用性或不侵犯任何第三方知识产权的暗示担保。

这些资源可供使用 TI 产品进行设计的熟练开发人员使用。您将自行承担以下全部责任：(1) 针对您的应用选择合适的 TI 产品，(2) 设计、验证并测试您的应用，(3) 确保您的应用满足相应标准以及任何其他功能安全、信息安全、监管或其他要求。

这些资源如有变更，恕不另行通知。TI 授权您仅可将这些资源用于研发本资源所述的 TI 产品的相关应用。严禁以其他方式对这些资源进行复制或展示。您无权使用任何其他 TI 知识产权或任何第三方知识产权。您应全额赔偿因在这些资源的使用中对 TI 及其代表造成的任何索赔、损害、成本、损失和债务，TI 对此概不负责。

TI 提供的产品受 [TI 的销售条款](#) 或 [ti.com](#) 上其他适用条款/TI 产品随附的其他适用条款的约束。TI 提供这些资源并不会扩展或以其他方式更改 TI 针对 TI 产品发布的适用的担保或担保免责声明。

TI 反对并拒绝您可能提出的任何其他或不同的条款。

邮寄地址：Texas Instruments, Post Office Box 655303, Dallas, Texas 75265
版权所有 © 2025，德州仪器 (TI) 公司