

bq27532-G1 用于 bq2425x 充电器的电池管理单元 Impedance Track™ 电量监测计

1 特性

- 电池电量计和充电器控制器适用于 1 节锂离子电池应用（最高容量 14,500mAh）
- 驻留在系统主板上
- 基于已获专利的 Impedance Track™ 技术的电池电量计量
 - 对电池放电曲线建模以精确预测剩余电量
 - 针对电池老化、电池自放电以及温度和速率低效情况进行自动调节
 - 低值感测电阻器（5 至 20mΩ）
- 采用可定制充电配置文件的电池充电控制器
 - 可根据温度配置的充电电压和电流
 - 可选择运行状态 (SoH) 和多级别充电配置文件
- 无主机自主电池管理系统
 - 减少了软件开销，提升了各平台间的可移植性同时缩短了 OEM 设计周期
 - 提高了安全性
- 运行时间提升
 - 通过 Impedance Track™ 技术延长电池续航时间
 - 能够对充电器终端进行更精确的控制
 - 提高了再充电阈值
- 智能充电 – 定制化和自适应充电配置文件
 - 基于 SoH 的充电器控制
 - 温度水平充电 (TLC)
- 适用于 bq2425x 单节开关模式电池充电器的独立电池充电控制器
- 用于连接系统微控制器端口的 400kHz I²C 接口

2 应用

- 智能手机、功能型手机和平板电脑
- 数码相机与视频摄像机
- 手持式终端
- MP3 或多媒体播放器

3 说明

bq27532-G1 系统端，锂离子电池管理单元是具有 Impedance Track™ 电量监测功能和对单节锂离子电池组进行充电控制的微控制器外设。电量监测计对系统微控制器固件开发的要求极低。电量监测计可配合 bq2425x 单节开关模式充电器管理嵌入式电池（不可拆卸）或可拆卸电池组。

此电量监测计使用已经获得专利的 Impedance Track 算法来进行电量计量，并提供诸如剩余电量 (mAh)，充电状态 (%), 续航时间 (分钟)，电池电压 (mV)、和温度 (°C) 和 SoH (%) 等信息。

通过该器件进行电池电量监测只需将 PACK+ (P+)、PACK- (P-) 和热敏电阻 (T) 连接至可拆卸电池组或嵌入式电池电路。15 引脚 NanoFree™ 芯片级封装 (CSP) 的尺寸为 2.61mm × 1.96mm，引线间距 0.5mm。它是空间受限类应用的理想选择。

器件信息⁽¹⁾

部件号	封装	封装尺寸 (标称值)
bq27532-G1	CSP (15)	2.61mm x 1.96mm

(1) 要了解所有可用封装，请见数据表末尾的可订购产品附录。

4 简化电路原理图

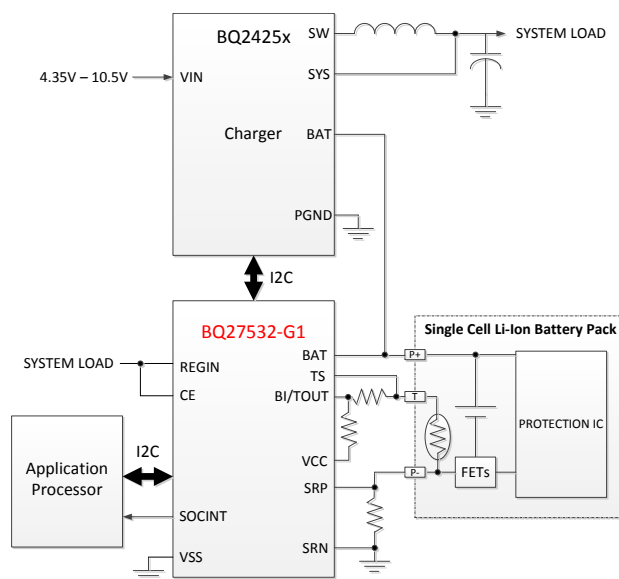

目录

1	特性	1	7.13	I ² C-compatible Interface Communication Timing Characteristics	7
2	应用	1	7.14	Typical Characteristics	7
3	说明	1	8	Detailed Description	9
4	简化电路原理图	1	8.1	Overview	9
5	修订历史记录	2	8.2	Functional Block Diagram	10
6	Pin Configuration and Functions	3	8.3	Feature Description	11
7	Specifications	4	8.4	Device Functional Modes	11
7.1	Absolute Maximum Ratings	4	8.5	Programming	12
7.2	Handling Ratings	4	9	Application and Implementation	17
7.3	Recommended Operating Conditions	4	9.1	Typical Application	18
7.4	Thermal Information	4	10	Power Supply Recommendations	21
7.5	Supply Current	5	10.1	Power Supply Decoupling	21
7.6	Digital Input and Output DC Electrical Characteristics	5	11	Layout	22
7.7	Power-on Reset	5	11.1	Layout Guidelines	22
7.8	2.5-V LDO Regulator	5	12	器件和文档支持	23
7.9	Internal Clock Oscillators	5	12.1	文档支持	23
7.10	ADC (Temperature and Cell Measurement) Characteristics	6	12.2	商标	23
7.11	Integrating ADC (Coulomb Counter) Characteristics	6	12.3	静电放电警告	23
7.12	Data Flash Memory Characteristics	6	12.4	术语表	23
			13	机械封装和可订购信息	24

5 修订历史记录

日期	修订版本	注释
2014 年 9 月	*	最初发布版本

6 Pin Configuration and Functions

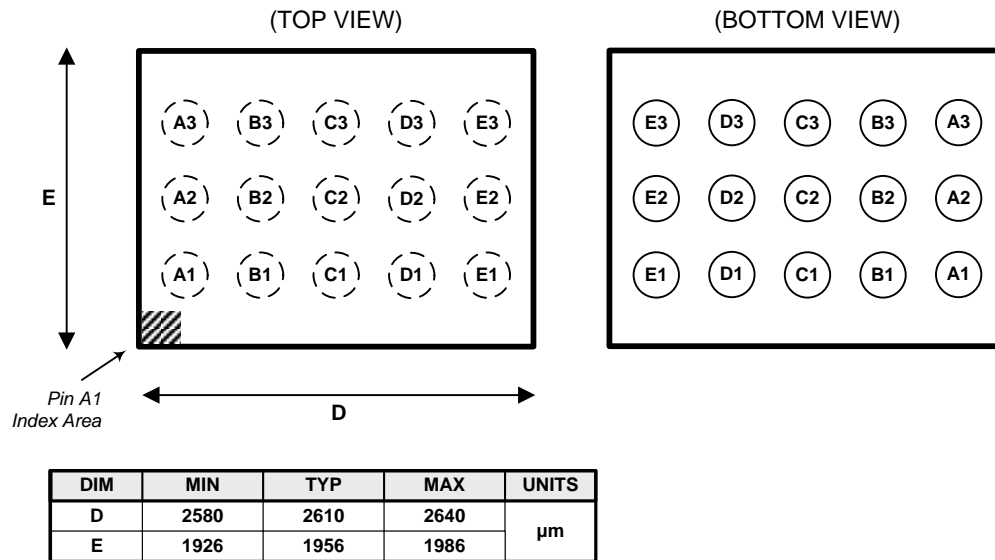

Pin Functions

PIN		TYPE ⁽¹⁾	DESCRIPTION
NAME	NUMBER		
BAT	E2	I	Cell-voltage measurement input. ADC input. TI recommends 4.8 V maximum for conversion accuracy.
BI/TOUT	E3	IO	Battery-insertion detection input. Power pin for pack thermistor network. Thermistor-multiplexer control pin. Use with pullup resistor > 1 MΩ (1.8 MΩ typical).
B_SCL	B2	O	Battery charger clock output line for chipset communication. Use without external pullup resistor. Push-pull output.
B_SDA	C3	IO	Battery charger data line for chipset communication. Use without external pullup resistor. Push-pull output.
CE	D2	I	Chip enable. Internal LDO is disconnected from REGIN when driven low. Note: CE has an internal ESD protection diode connected to REGIN. TI recommends maintaining $V_{CE} \leq V_{REGIN}$ under all conditions.
REGIN	E1	P	Regulator input. Decouple with 0.1-μF ceramic capacitor to V_{SS} .
SCL	A3	I	Slave I ² C serial communications clock input line for communication with system (master). Open-drain IO. Use with 10-kΩ pullup resistor (typical).
SDA	B3	IO	Slave I ² C serial communications data line for communication with system (master). Open-drain IO. Use with 10-kΩ pullup resistor (typical).
SOC_INT	A2	IO	SOC state interrupts output. Generates a pulse as described in <i>SLUUB04, bq27532-G1 Technical Reference Manual</i> . Open-drain output.
SRN	B1	AI	Analog input pin connected to the internal coulomb counter where SRN is nearest the V_{SS} connection. Connect to 5- to 20-mΩ sense resistor.
SRP	A1	AI	Analog input pin connected to the internal coulomb counter where SRP is nearest the PACK- connection. Connect to 5- to 20-mΩ sense resistor.
TS	D3	AI	Pack thermistor voltage sense (use 103AT-type thermistor). ADC input.
V_{CC}	D1	P	Regulator output and bq27532-G1 device power. Decouple with 1-μF ceramic capacitor to V_{SS} . Pin is not intended to power additional external loads.
V_{SS}	C1, C2	P	Device ground

(1) IO = Digital input-output, AI = Analog input, P = Power connection

7 Specifications

7.1 Absolute Maximum Ratings

 over operating free-air temperature range (unless otherwise noted)⁽¹⁾

		MIN	MAX	UNIT
V _{REGIN}	Regulator input range	-0.3	5.5	V
		-0.3	6.0 ⁽²⁾	V
V _{CE}	CE input pin	-0.3	V _{REGIN} + 0.3	V
V _{CC}	Supply voltage range	-0.3	2.75	V
V _{IOD}	Open-drain IO pins (SDA, SCL, SOC_INT)	-0.3	5.5	V
V _{BAT}	BAT input pin	-0.3	5.5	V
		-0.3	6.0 ⁽²⁾	V
V _I	Input voltage range to all other pins (BI/TOUT, TS, SRP, SRN, BSCL, BSDA)	-0.3	V _{CC} + 0.3	V
T _A	Operating free-air temperature range	-40	85	°C

- (1) Stresses beyond those listed as *absolute maximum ratings* may cause permanent damage to the device. These are stress ratings only, and functional operation of the device at these or any other conditions beyond those indicated as recommended operating conditions is not implied. Exposure to absolute-maximum-rated conditions for extended periods may affect device reliability.
- (2) Condition not to exceed 100 hours at 25°C lifetime.

7.2 Handling Ratings

		MIN	MAX	UNIT	
T _{stg}	Storage temperature range	-65	150	°C	
V _(ESD)	Electrostatic discharge	Human-body model (HBM), per ANSI/ESDA/JEDEC JS-001, BAT pin ⁽¹⁾	0	1.5	kV
		Charged device model (CDM), per JEDEC specification JESD22-C101, all other pins ⁽²⁾	0	2	

- (1) JEDEC document JEP155 states that 500-V HBM allows safe manufacturing with a standard ESD control process.
- (2) JEDEC document JEP157 states that 250-V CDM allows safe manufacturing with a standard ESD control process.

7.3 Recommended Operating Conditions

 T_A = -40°C to 85°C, V_{REGIN} = V_{BAT} = 3.6 V (unless otherwise noted)

PARAMETER	TEST CONDITIONS	MIN	NOM	MAX	UNIT
V _{REGIN}	Supply voltage	No operating restrictions	2.8	4.5	V
		No flash writes	2.45	2.8	
C _{REGIN}	External input capacitor for internal LDO between REGIN and V _{SS}	Nominal capacitor values specified. Recommend a 5% ceramic X5R-type capacitor located close to the device.		0.1	μF
C _{LDO25}	External output capacitor for internal LDO between V _{CC} and V _{SS}	0.47	1		μF
t _{PUCD}	Power-up communication delay		250		ms

7.4 Thermal Information

	THERMAL METRIC ⁽¹⁾	CSP (15 PINS)	UNIT
R _{θJA}	Junction-to-ambient thermal resistance	70	°C/W
R _{θJC(top)}	Junction-to-case (top) thermal resistance	17	
R _{θJB}	Junction-to-board thermal resistance	20	
ψ _{JT}	Junction-to-top characterization parameter	1	
ψ _{JB}	Junction-to-board characterization parameter	18	
R _{θJC(bottom)}	Junction-to-case (bottom) thermal resistance	n/a	

- (1) For more information about traditional and new thermal metrics, see the *IC Package Thermal Metrics* application report, [SPRA953](#).

7.5 Supply Current

 $T_A = 25^\circ\text{C}$ and $V_{\text{REGIN}} = V_{\text{BAT}} = 3.6\text{ V}$ (unless otherwise noted)

PARAMETER		TEST CONDITIONS	MIN	TYP	MAX	UNIT
I_{CC} ⁽¹⁾	Normal operating-mode current	Fuel gauge in NORMAL mode $I_{\text{LOAD}} > \textit{Sleep current}$		118		μA
$I_{\text{SLP+}}$ ⁽¹⁾	Sleep+ operating-mode current	Fuel gauge in SLEEP+ mode $I_{\text{LOAD}} < \textit{Sleep current}$		62		μA
I_{SLP} ⁽¹⁾	Low-power storage-mode current	Fuel gauge in SLEEP mode $I_{\text{LOAD}} < \textit{Sleep current}$		23		μA
I_{HIB} ⁽¹⁾	Hibernate operating-mode current	Fuel gauge in HIBERNATE mode $I_{\text{LOAD}} < \textit{Hibernate current}$		8		μA

(1) Specified by design. Not production tested. Actual supply current consumption will vary slightly depending on firmware operation and dataflash configuration.

7.6 Digital Input and Output DC Electrical Characteristics

 $T_A = -40^\circ\text{C}$ to 85°C , typical values at $T_A = 25^\circ\text{C}$ and $V_{\text{REGIN}} = 3.6\text{ V}$ (unless otherwise noted)

PARAMETER		TEST CONDITIONS	MIN	TYP	MAX	UNIT
V_{OL}	Output voltage, low (SCL, SDA, SOC_INT, BSDA, BSCL)	$I_{\text{OL}} = 3\text{ mA}$			0.4	V
$V_{\text{OH(PP)}}$	Output voltage, high (BSDA, BSCL)	$I_{\text{OH}} = -1\text{ mA}$	$V_{\text{CC}} - 0.5$			V
$V_{\text{OH(OD)}}$	Output voltage, high (SDA, SCL, SOC_INT)	External pullup resistor connected to V_{CC}	$V_{\text{CC}} - 0.5$			V
V_{IL}	Input voltage, low (SDA, SCL)		-0.3		0.6	V
	Input voltage, low (BI/TOUT)	BAT INSERT CHECK MODE active	-0.3		0.6	V
V_{IH}	Input voltage, high (SDA, SCL)		1.2			V
	Input voltage, high (BI/TOUT)	BAT INSERT CHECK MODE active	1.2	$V_{\text{CC}} + 0.3$		V
$V_{\text{IL(CE)}}$	Input voltage, low (CE)	$V_{\text{REGIN}} = 2.8$ to 4.5 V			0.8	V
$V_{\text{IH(CE)}}$	Input voltage, high (CE)		2.65			V
I_{IKG} ⁽¹⁾	Input leakage current (IO pins)				0.3	μA

(1) Specified by design. Not production tested.

7.7 Power-on Reset

 $T_A = -40^\circ\text{C}$ to 85°C , typical values at $T_A = 25^\circ\text{C}$ and $V_{\text{REGIN}} = 3.6\text{ V}$ (unless otherwise noted)

PARAMETER		MIN	TYP	MAX	UNIT
$V_{\text{IT+}}$	Positive-going battery voltage input at V_{CC}	2.05	2.15	2.20	V
V_{HYS}	Power-on reset hysteresis		115		mV

7.8 2.5-V LDO Regulator

 $T_A = -40^\circ\text{C}$ to 85°C , $C_{\text{LDO25}} = 1\text{ }\mu\text{F}$, $V_{\text{REGIN}} = 3.6\text{ V}$ (unless otherwise noted)

PARAMETER		TEST CONDITIONS	MIN	NOM	MAX	UNIT
V_{REG25}	Regulator output voltage (V_{CC})	$2.8\text{ V} \leq V_{\text{REGIN}} \leq 4.5\text{ V}$, $I_{\text{OUT}} \leq 16\text{ mA}$ ⁽¹⁾	2.3	2.5	2.6	V
		$2.45\text{ V} \leq V_{\text{REGIN}} < 2.8\text{ V}$ (low battery), $I_{\text{OUT}} \leq 3\text{ mA}$	2.3			V

(1) LDO output current, I_{OUT} , is the total load current. LDO regulator should be used to power internal fuel gauge only.

7.9 Internal Clock Oscillators

 $T_A = -40^\circ\text{C}$ to 85°C , $2.4\text{ V} < V_{\text{CC}} < 2.6\text{ V}$; typical values at $T_A = 25^\circ\text{C}$ and $V_{\text{CC}} = 2.5\text{ V}$ (unless otherwise noted)

PARAMETER		MIN	TYP	MAX	UNIT
f_{OSC}	High-frequency oscillator		8.389		MHz
f_{LOSC}	Low-frequency oscillator		32.768		kHz

7.10 ADC (Temperature and Cell Measurement) Characteristics

 $T_A = -40^{\circ}\text{C}$ to 85°C , $2.4\text{ V} < V_{CC} < 2.6\text{ V}$; typical values at $T_A = 25^{\circ}\text{C}$ and $V_{CC} = 2.5\text{ V}$ (unless otherwise noted)

PARAMETER	TEST CONDITIONS	MIN	TYP	MAX	UNIT
V_{ADC1}	Input voltage range (TS)	$V_{\text{SS}} - 0.125$		2	V
V_{ADC2}	Input voltage range (BAT)	$V_{\text{SS}} - 0.125$		5	V
$V_{\text{IN(ADC)}}$	Input voltage range	0.05		1	V
G_{TEMP}	Internal temperature sensor voltage gain		-2		mV/ $^{\circ}\text{C}$
$t_{\text{ADC_CONV}}$	Conversion time			125	ms
	Resolution	14		15	bits
$V_{\text{OS(ADC)}}$	Input offset		1		mV
$Z_{\text{ADC1}}^{(1)}$	Effective input resistance (TS)	8			M Ω
$Z_{\text{ADC2}}^{(1)}$	Effective input resistance (BAT)	Device not measuring cell voltage			M Ω
		Device measuring cell voltage		100	k Ω
$I_{\text{lkq(ADC)}}^{(1)}$	Input leakage current			0.3	μA

(1) Specified by design. Not tested in production.

7.11 Integrating ADC (Coulomb Counter) Characteristics

 $T_A = -40^{\circ}\text{C}$ to 85°C , $2.4\text{ V} < V_{CC} < 2.6\text{ V}$; typical values at $T_A = 25^{\circ}\text{C}$ and $V_{CC} = 2.5\text{ V}$ (unless otherwise noted)

PARAMETER	TEST CONDITIONS	MIN	TYP	MAX	UNIT
V_{SR}	Input voltage range, $V_{(\text{SRP})}$ and $V_{(\text{SRN})}$	$V_{\text{SR}} = V_{(\text{SRP})} - V_{(\text{SRN})}$		0.125	V
$t_{\text{SR_CONV}}$	Conversion time		1		s
	Resolution	14		15	bits
$V_{\text{OS(SR)}}$	Input offset		10		μV
INL	Integral nonlinearity error		± 0.007	± 0.034	% FSR
$Z_{\text{IN(SR)}}^{(1)}$	Effective input resistance	2.5			M Ω
$I_{\text{lkq(SR)}}^{(1)}$	Input leakage current			0.3	μA

(1) Specified by design. Not tested in production.

7.12 Data Flash Memory Characteristics

 $T_A = -40^{\circ}\text{C}$ to 85°C , $2.4\text{ V} < V_{CC} < 2.6\text{ V}$; typical values at $T_A = 25^{\circ}\text{C}$ and $V_{CC} = 2.5\text{ V}$ (unless otherwise noted)

PARAMETER	TEST CONDITIONS	MIN	TYP	MAX	UNIT
$t_{\text{DR}}^{(1)}$	Data retention	10			Years
	Flash-programming write cycles ⁽¹⁾	20,000			Cycles
$t_{\text{WORDPROG}}^{(1)}$	Word programming time			2	ms
$I_{\text{CCPROG}}^{(1)}$	Flash-write supply current		5	10	mA
$t_{\text{DFERASE}}^{(1)}$	Data flash master erase time	200			ms
$t_{\text{IFERASE}}^{(1)}$	Instruction flash master erase time	200			ms
$t_{\text{PGERASE}}^{(1)}$	Flash page erase time	20			ms

(1) Specified by design. Not production tested

7.13 I²C-compatible Interface Communication Timing Characteristics

T_A = -40°C to 85°C, 2.4 V < V_{CC} < 2.6 V; typical values at T_A = 25°C and V_{CC} = 2.5 V (unless otherwise noted)

PARAMETER		MIN	TYP	MAX	UNIT
t _r	SCL or SDA rise time			300	ns
t _f	SCL or SDA fall time			300	ns
t _{w(H)}	SCL pulse duration (high)	600			ns
t _{w(L)}	SCL pulse duration (low)	1.3			µs
t _{su(STA)}	Setup for repeated start	600			ns
t _{d(STA)}	Start to first falling edge of SCL	600			ns
t _{su(DAT)}	Data setup time	100			ns
t _{h(DAT)}	Data hold time	0			ns
t _{su(STOP)}	Setup time for stop	600			ns
t _(BUF)	Bus free time between stop and start	66			µs
f _{SCL}	Clock frequency ⁽¹⁾			400	kHz

(1) If the clock frequency (f_{SCL}) is > 100 kHz, use 1-byte write commands for proper operation. All other transactions types are supported at 400 kHz (see I²C Interface and I²C Command Waiting Time).

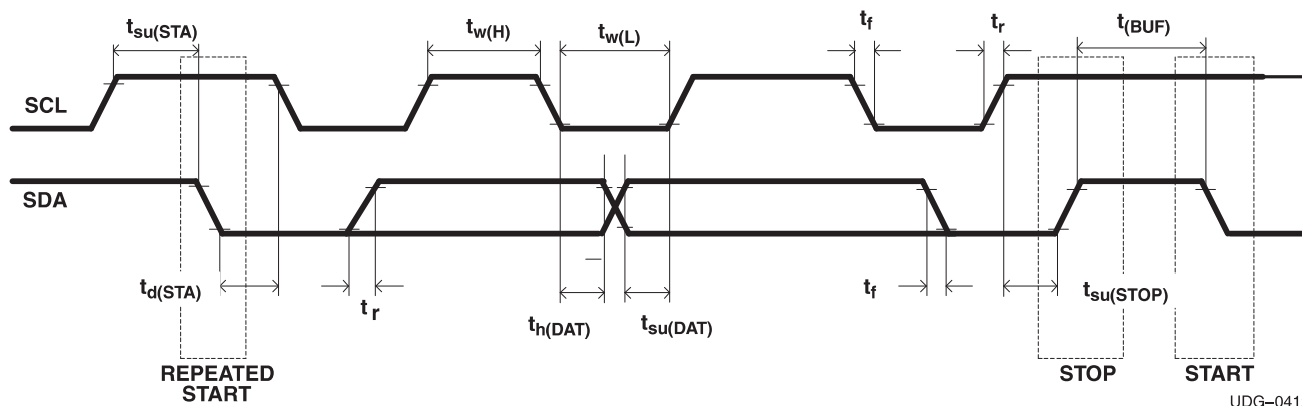

Figure 1. I²C-compatible Interface Timing Diagrams

7.14 Typical Characteristics



图 2. Regulator Output Voltage vs. Temperature



图 3. High-Frequency Oscillator Frequency vs. Temperature

Typical Characteristics (接下页)

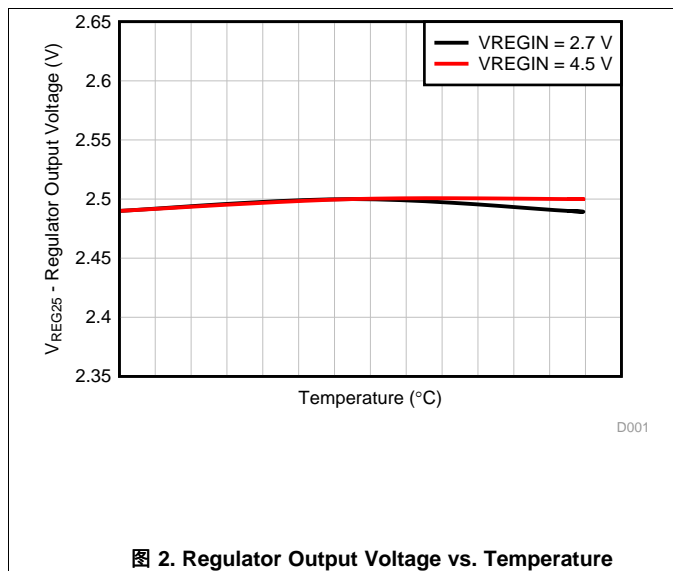

图 4. Low-Frequency Oscillator Frequency vs. Temperature

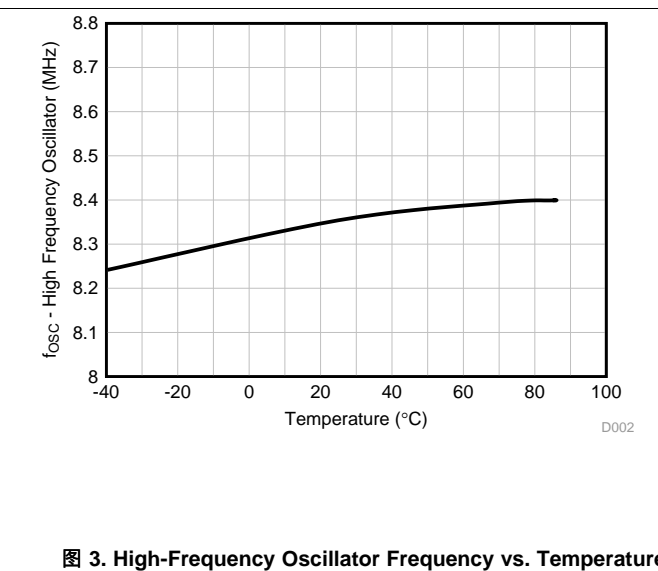

图 5. Reported Internal Temperature Measurement vs. Temperature

8 Detailed Description

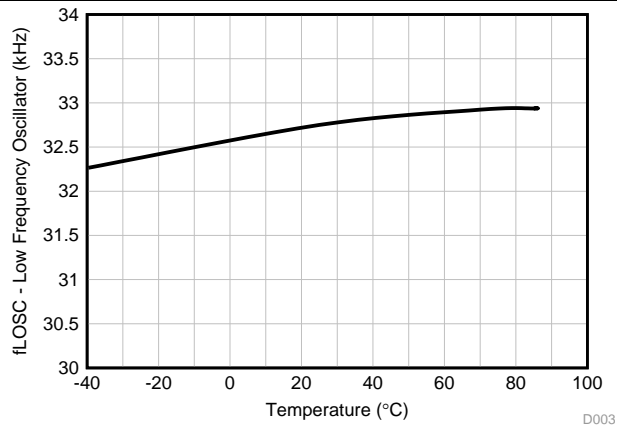
8.1 Overview

The fuel gauge accurately predicts the battery capacity and other operational characteristics of a single, Li-based, rechargeable cell. It can be interrogated by a system processor to provide cell information, such as remaining capacity and state-of-charge (SOC) as well as SOC interrupt signal to the host.

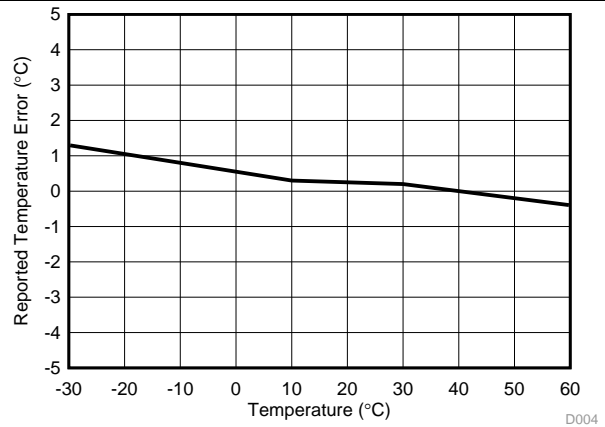
The fuel gauge can control a bq2425x Charger IC without the intervention from an application system processor. Using the bq27532-G1 and bq2425x chipset, batteries can be charged with the typical constant-current, constant-voltage (CCCV) profile or charged using a Multi-Level Charging (MLC) algorithm.

The fuel gauge can also be configured to suggest charge voltage and current values to the system so that the host can control a charger that is not part of the bq2425x charger family.

注

Formatting conventions used in this document:

Commands: *italics* with parentheses and no breaking spaces, for example, *Control()*

Data flash: *italics*, **bold**, and *breaking spaces*, for example, ***Design Capacity***

Register bits and flags: brackets and *italics*, for example, *[TDA]*

Data flash bits: brackets, *italics* and **bold**, for example, ***[LED1]***

Modes and states: ALL CAPITALS, for example, UNSEALED mode

8.2 Functional Block Diagram

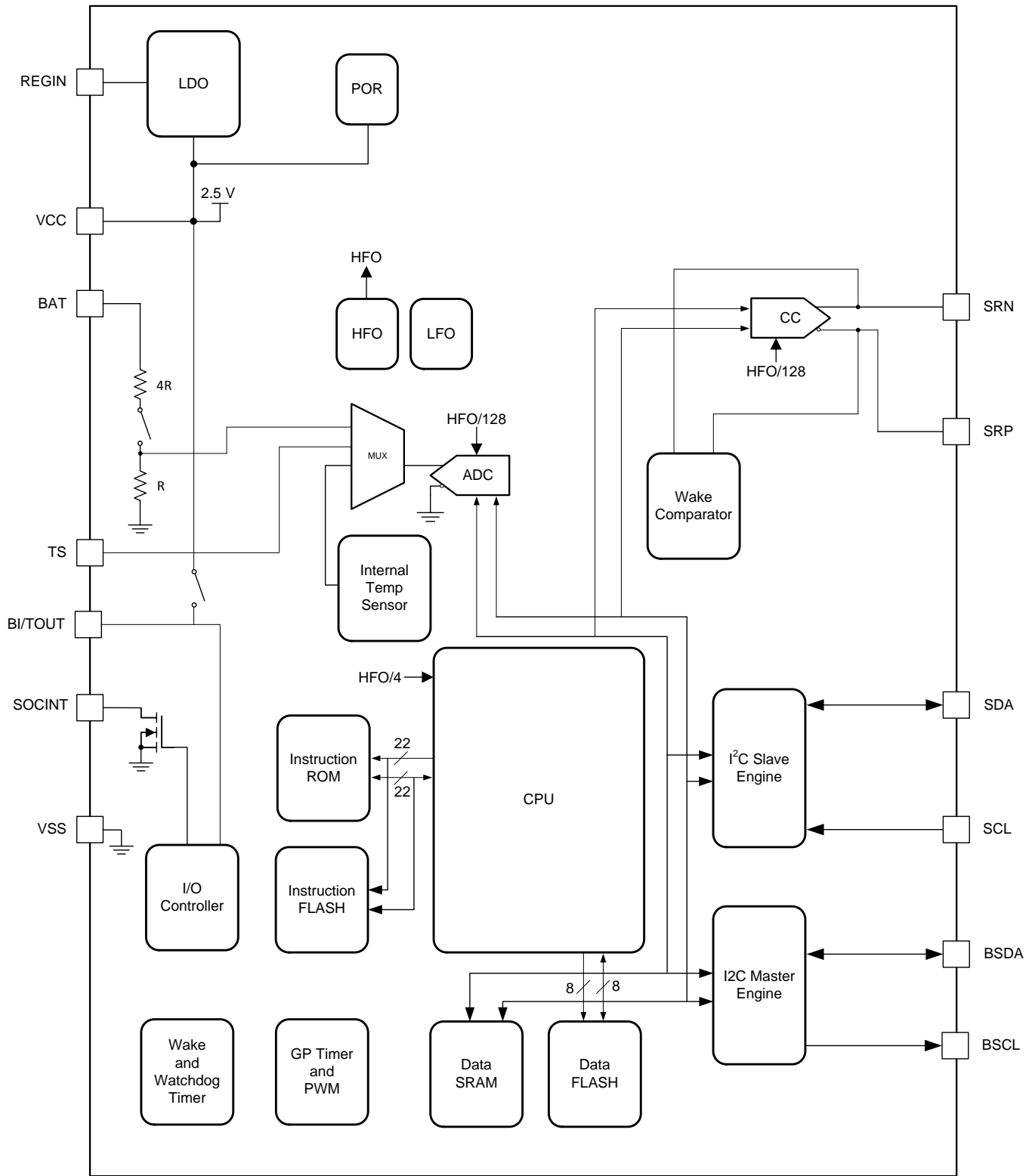

8.3 Feature Description

Information is accessed through a series of commands, called *Standard Commands*. Further capabilities are provided by the additional *Extended Commands* set. Both sets of commands, indicated by the general format *Command()*, are used to read and write information contained within the control and status registers, as well as its data flash locations. Commands are sent from system to gauge using the I²C serial communications engine, and can be executed during application development, pack manufacture, or end-equipment operation.

Cell information is stored in non-volatile flash memory. Many of these data flash locations are accessible during application development. They cannot, generally, be accessed directly during end-equipment operation. Access to these locations is achieved by either use of the companion evaluation software, through individual commands, or through a sequence of data-flash-access commands. To access a desired data flash location, the correct data flash subclass and offset must be known.

The key to the high-accuracy gas gauging prediction is the TI proprietary Impedance Track™ algorithm. This algorithm uses cell measurements, characteristics, and properties to create SOC predictions that can achieve less than 1% error across a wide variety of operating conditions and over the lifetime of the battery.

The fuel gauge measures the charging and discharging of the battery by monitoring the voltage across a small-value series sense resistor (5 to 20 mΩ, typical) located between the system V_{SS} and the battery PACK-terminal. When a cell is attached to the fuel gauge, cell impedance is computed, based on cell current, cell open-circuit voltage (OCV), and cell voltage under loading conditions.

The external temperature sensing is optimized with the use of a high-accuracy negative temperature coefficient (NTC) thermistor with R₂₅ = 10.0 kΩ ±1%, B_{25/85} = 3435 K ± 1% (such as Semitec NTC 103AT). The fuel gauge can also be configured to use its internal temperature sensor. When an external thermistor is used, a 18.2-kΩ pullup resistor between the BI/TOUT and TS pins is also required. The fuel gauge uses temperature to monitor the battery-pack environment, which is used for fuel gauging and cell protection functionality.

To minimize power consumption, the fuel gauge has different power modes: NORMAL, SLEEP, SLEEP+, HIBERNATE, and BAT INSERT CHECK. The fuel gauge passes automatically between these modes, depending upon the occurrence of specific events, though a system processor can initiate some of these modes directly.

For complete operational details, see [SLUUB04, bq27532-G1 Technical Reference Manual](#).

8.4 Device Functional Modes

8.4.1 Functional Description

The fuel gauge measures the cell voltage, temperature, and current to determine battery SOC. The fuel gauge monitors the charging and discharging of the battery by sensing the voltage across a small-value resistor (5 mΩ to 20 mΩ, typical) between the SRP and SRN pins and in series with the cell. By integrating charge passing through the battery, the battery SOC is adjusted during battery charge or discharge.

The total battery capacity is found by comparing states of charge before and after applying the load with the amount of charge passed. When an application load is applied, the impedance of the cell is measured by comparing the OCV obtained from a predefined function for present SOC with the measured voltage under load. Measurements of OCV and charge integration determine chemical SOC and chemical capacity (Q_{max}). The initial Q_{max} values are taken from a cell manufacturers' data sheet multiplied by the number of parallel cells. It is also used for the value in **Design Capacity**. The fuel gauge acquires and updates the battery-impedance profile during normal battery usage. It uses this profile, along with SOC and the Q_{max} value, to determine *FullChargeCapacity()* and *StateOfCharge()*, specifically for the present load and temperature. *FullChargeCapacity()* is reported as capacity available from a fully-charged battery under the present load and temperature until *Voltage()* reaches the **Terminate Voltage**. *NominalAvailableCapacity()* and *FullAvailableCapacity()* are the uncompensated (no or light load) versions of *RemainingCapacity()* and *FullChargeCapacity()*, respectively.

The fuel gauge has two flags accessed by the *Flags()* function that warn when the battery SOC has fallen to critical levels. When *RemainingCapacity()* falls below the first capacity threshold as specified in **SOC1 Set Threshold**, the [SOC1] (*State of Charge Initial*) flag is set. The flag is cleared once *RemainingCapacity()* rises above **SOC1 Clear Threshold**.

When the voltage is discharged to **Terminate Voltage**, the SOC will be set to 0.

8.5 Programming

8.5.1 Standard Data Commands

The fuel gauge uses a series of 2-byte standard commands to enable system reading and writing of battery information. Each standard command has an associated command-code pair, as indicated in [Table 1](#). Because each command consists of two bytes of data, two consecutive I²C transmissions must be executed both to initiate the command function, and to read or write the corresponding two bytes of data. Additional details are found in the [SLUUB04, bq27532-G1 Technical Reference Manual](#).

Table 1. Standard Commands

NAME	COMMAND CODE	UNIT	SEALED ACCESS	UNSEALED ACCESS
<i>Control()</i>	0x00 and 0x01	NA	RW	RW
<i>AtRate()</i>	0x02 and 0x03	mA	RW	RW
<i>AtRateTimeToEmpty()</i>	0x04 and 0x05	Minutes	R	RW
<i>Temperature()</i>	0x06 and 0x07	0.1 K	RW	RW
<i>Voltage()</i>	0x08 and 0x09	mV	R	RW
<i>Flags()</i>	0x0A and 0x0B	Hex	R	RW
<i>NominalAvailableCapacity()</i>	0x0C and 0x0D	mAh	R	RW
<i>FullAvailableCapacity()</i>	0x0E and 0x0F	mAh	R	RW
<i>RemainingCapacity()</i>	0x10 and 0x11	mAh	R	RW
<i>FullChargeCapacity()</i>	0x12 and 0x13	mAh	R	RW
<i>AverageCurrent()</i>	0x14 and 0x15	mA	R	RW
<i>InternalTemperature()</i>	0x16 and 0x17	0.1 K	R	RW
<i>ResScale()</i>	0x18 and 0x19	Num	R	RW
<i>ChargingLevel()</i>	0x1A and 0x1B	Num	R	RW
<i>StateOfHealth()</i>	0x1C and 0x1D	% / num	R	RW
<i>CycleCount()</i>	0x1E and 0x1F	Counters	R	R
<i>StateOfCharge()</i>	0x20 and 0x21	%	R	R
<i>InstantaneousCurrentReading()</i>	0x22 and 0x23	mA	R	RW
<i>FineQPass()</i>	0x24 and 0x25	mAh	R	RW
<i>FineQPassFract()</i>	0x26 and 0x27	num	R	RW
<i>ProgChargingCurrent()</i>	0x28 and 0x29	mA	R	RW
<i>ProgChargingVoltage()</i>	0x2A and 0x2B	mV	R	RW
<i>LevelTaperCurrent()</i>	0x2C and 0x2D	mA	R	RW
<i>CalcChargingCurrent()</i>	0x2E and 0x2F	mA	R	RW
<i>CalcChargingVoltage()</i>	0x30 and 0x31	mV	R	RW
<i>ChargerStatus()</i>	0x32	Hex	R	RW
<i>ChargReg0()</i>	0x33	Hex	RW	RW
<i>ChargReg1()</i>	0x34	Hex	RW	RW
<i>ChargReg2()</i>	0x35	Hex	RW	RW
<i>ChargReg3()</i>	0x36	Hex	RW	RW
<i>ChargReg4()</i>	0x37	Hex	RW	RW
<i>ChargReg5()</i>	0x38	Hex	RW	RW
<i>ChargReg6()</i>	0x39	Hex	RW	RW
<i>RemainingCapacityUnfiltered()</i>	0x6C and 0x6D	mAh	R	RW
<i>RemainingCapacityFiltered()</i>	0x6E and 0x6F	mAh	R	RW
<i>FullChargeCapacityUnfiltered()</i>	0x70 and 0x71	mAh	R	RW
<i>FullChargeCapacityFiltered()</i>	0x72 and 0x73	mAh	R	RW
<i>TrueSOC()</i>	0x74 and 0x75	%	R	RW
<i>MaxCurrent()</i>	0x76 and 0x77	mA	R	RW

8.5.2 Control(): 0x00 and 0x01

Issuing a *Control()* command requires a subsequent 2-byte subcommand. These additional bytes specify the particular control function desired. The *Control()* command allows the system to control specific features of the fuel gauge during normal operation and additional features when the fuel gauge is in different access modes, as described in [Table 2](#). Additional details are found in the [SLUUB04, bq27532-G1 Technical Reference Manual](#).

Table 2. Control() Subcommands

CONTROL FUNCTION	CONTROL DATA	SEALED ACCESS	DESCRIPTION
CONTROL_STATUS	0x0000	Yes	Reports the status of HIBERNATE, IT, and so on
DEVICE_TYPE	0x0001	Yes	Reports the device type (for example, 0x0532 for bq27532-G1)
FW_VERSION	0x0002	Yes	Reports the firmware version on the device type
HW_VERSION	0x0003	Yes	Reports the hardware version of the device type
MLC_ENABLE	0x0004	Yes	Charge profile is based on MaxLife profile
MLC_DISABLE	0x0005	Yes	Charge profile is solely based on charge temperature tables and, if enabled, State of Health
CLEAR_IMAX_INT	0x0006	Yes	Clears the IMAX status bit and the interrupt signal from SOC_INT pin.
PREV_MACWRITE	0x0007	Yes	Returns previous MAC subcommand code
CHEM_ID	0x0008	Yes	Reports the chemical identifier of the Impedance Track™ configuration
BOARD_OFFSET	0x0009	No	Forces the device to measure and store the board offset
CC_OFFSET	0x000A	No	Forces the device to measure the internal CC offset
CC_OFFSET_SAVE	0x000B	No	Forces the device to store the internal CC offset
OCV_CMD	0x000C	Yes	Request the gauge to take a OCV measurement
BAT_INSERT	0x000D	Yes	Forces the BAT_DET bit set when the [BIE] bit is 0
BAT_REMOVE	0x000E	Yes	Forces the BAT_DET bit clear when the [BIE] bit is 0
SET_HIBERNATE	0x0011	Yes	Forces CONTROL_STATUS [HIBERNATE] to 1
CLEAR_HIBERNATE	0x0012	Yes	Forces CONTROL_STATUS [HIBERNATE] to 0
SET_SLEEP+	0x0013	Yes	Forces CONTROL_STATUS [SNOOZE] to 1
CLEAR_SLEEP+	0x0014	Yes	Forces CONTROL_STATUS [SNOOZE] to 0
ILIMIT_LOOP_ENABLE	0x0015	Yes	When the gauge is not connected to the charger through I ² C, this command indicates to the gauge that there is a charger input current limiting loop active. Disables charge termination detection by the gauge.
ILIMIT_LOOP_DISABLE	0x0016	Yes	When the gauge is not connected to the charger through I ² C, this command indicates to the gauge that battery charge current is not limited. Allows charge termination detection by the gauge.
SHIPMODE_ENABLE	0x0017	Yes	Commands the bq2425x to turn off BATFET after a delay time programmed in data flash so that system load does not draw power from the battery
SHIPMODE_DISABLE	0x0018	Yes	Commands the bq2425x to disregard turning off BATFET before the delay time or commands BATFET to turn on if a VIN had power during the SHIPMODE enabling process
CHG_ENABLE	0x001A	Yes	Enable charger. Charge will continue as dictated by the gauge charging algorithm.
CHG_DISABLE	0x001B	Yes	Disable charger (Set \overline{CE} bit of bq2425x)
GG_CHGRCTL_ENABLE	0x001C	Yes	Enables the gas gauge to control the charger while continuously resetting the charger watchdog
GG_CHGRCTL_DISABLE	0x001D	Yes	The gas gauge stops resetting the charger watchdog
SMOOTH_SYNC	0x001E	Yes	Synchronizes <i>RemainingCapacityFiltered()</i> and <i>FullChargeCapacityFiltered()</i> with <i>RemainingCapacityUnfiltered()</i> and <i>FullChargeCapacityUnfiltered()</i>
DF_VERSION	0x001F	Yes	Returns the Data Flash Version
SEALED	0x0020	No	Places device in SEALED access mode
IT_ENABLE	0x0021	No	Enables the Impedance Track™ algorithm
RESET	0x0041	No	Forces a full reset of the bq27532-G1 device

8.5.3 Charger Data Commands

The charger registers are mapped to a series of single-byte Charger Data Commands to enable system reading and writing of battery charger registers. During charger power up, the registers are initialized to Charger Reset State. The fuel gauge can change the values of these registers during the System Reset State.

Each of the bits in the Charger Data Commands can be read or write. Note that System Access can be different from the read or write access as defined in bq2425x charger hardware. The fuel gauge may block write access to the charger hardware when the bit function is controlled by the fuel gauge exclusively. For example, the [VBATREGx] bits of *Chrgr_Reg2* are controlled by the fuel gauge and cannot be modified by system.

The fuel gauge reads the corresponding registers of *Chrgr_Reg0*() and *Chrgr_Reg2*() every second to mirror the charger status. Other registers in the bq2425x device are read when registers are modified by the fuel gauge.

表 3. Charger Data Commands

NAME	COMMAND CODE	bq2425x CHARGER MEMORY LOCATION	SEALED ACCESS	UNSEALED ACCESS	REFRESH RATE
<i>ChargerStatus</i> ()	CHGRSTAT	0x32	NA	R	Every second
<i>Chrgr_Reg0</i> ()	CHGR0	0x33	0x00	RW	Every second
<i>Chrgr_Reg1</i> ()	CHGR1	0x34	0x01	RW	Data change
<i>Chrgr_Reg2</i> ()	CHGR2	0x35	0x02	RW	Every second
<i>Chrgr_Reg3</i> ()	CHGR3	0x36	0x03	RW	Data change
<i>Chrgr_Reg4</i> ()	CHGR4	0x37	0x04	RW	Every second
<i>Chrgr_Reg5</i> ()	CHGR5	0x38	0x05	RW	Data change
<i>Chrgr_Reg6</i> ()	CHGR6	0x39	0x06	RW	Data change

8.5.4 Communications

8.5.4.1 I²C Interface

The fuel gauge supports the standard I²C read, incremental read, quick read, one-byte write, and incremental write functions. The 7-bit device address (ADDR) is the most significant 7 bits of the hex address and is fixed as 1010101. The first 8 bits of the I²C protocol are, therefore, 0xAA or 0xAB for write or read, respectively.

Host generated Gauge generated

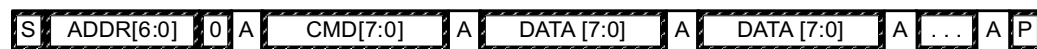
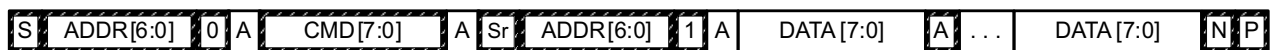
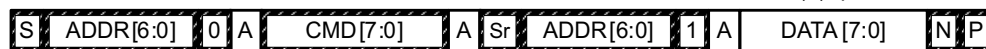

(S = Start, Sr = Repeated Start, A = Acknowledge, N = No Acknowledge, and P = Stop).

The quick read returns data at the address indicated by the address pointer. The address pointer, a register internal to the I²C communication engine, increments whenever data is acknowledged by the fuel gauge or the I²C master. "Quick writes" function in the same manner and are a convenient means of sending multiple bytes to consecutive command locations (such as two-byte commands that require two bytes of data).

The following command sequences are not supported:

Attempt to write a read-only address (NACK after data sent by master):

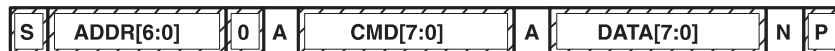

Attempt to read an address above 0x6B (NACK command):



8.5.4.2 I²C Time Out

The I²C engine releases both SDA and SCL if the I²C bus is held low for 2 seconds. If the fuel gauge is holding the lines, releasing them frees them for the master to drive the lines. If an external condition is holding either of the lines low, the I²C engine enters the low-power SLEEP mode.

8.5.4.3 I²C Command Waiting Time

To ensure proper operation at 400 kHz, a $t_{(BUF)} \geq 66 \mu s$ bus-free waiting time must be inserted between all packets addressed to the fuel gauge. In addition, if the SCL clock frequency (f_{SCL}) is > 100 kHz, use individual 1-byte write commands for proper data flow control. The following diagram shows the standard waiting time required between issuing the control subcommand the reading the status result. For read-write standard command, a minimum of 2 seconds is required to get the result updated. For read-only standard commands, there is no waiting time required, but the host must not issue any standard command more than two times per second. Otherwise, the gauge could result in a reset issue due to the expiration of the watchdog timer.

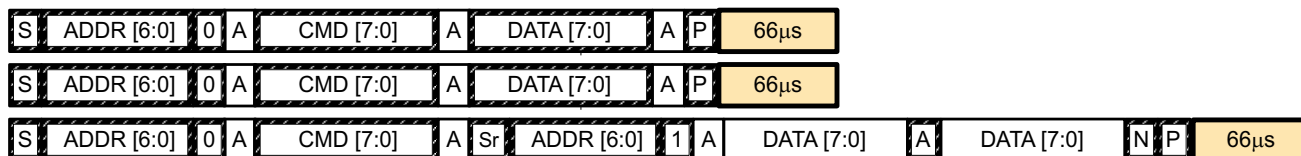

Waiting time inserted between two 1-byte write packets for a subcommand and reading results
(required for $100 \text{ kHz} < f_{SCL} \leq 400 \text{ kHz}$)

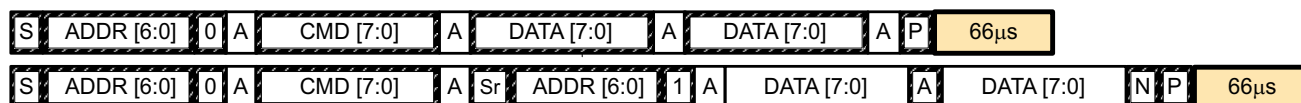

Waiting time inserted between incremental 2-byte write packet for a subcommand and reading results
(acceptable for $f_{SCL} \leq 100 \text{ kHz}$)

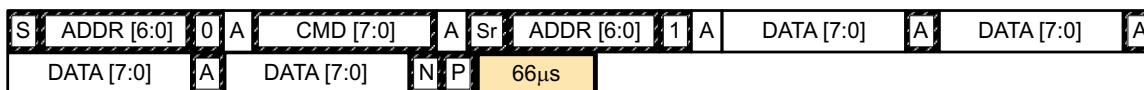

Waiting time inserted after incremental read

8.5.4.4 I²C Clock Stretching

A clock stretch can occur during all modes of fuel gauge operation. In SLEEP and HIBERNATE modes, a short clock stretch occurs on all I²C traffic as the device must wake-up to process the packet. In the other modes (INITIALIZATION, NORMAL) clock stretching only occurs for packets addressed for the fuel gauge. The majority of clock stretch periods are small as the I²C interface performs normal data flow control. However, less frequent yet more significant clock stretch periods may occur as blocks of data flash are updated. The following table summarizes the approximate clock stretch duration for various fuel gauge operating conditions.

GAUGING MODE	OPERATING CONDITION / COMMENT	APPROXIMATE DURATION
SLEEP HIBERNATE	Clock stretch occurs at the beginning of all traffic as the device wakes up.	≤ 4 ms
INITIALIZATION NORMAL	Clock stretch occurs within the packet for flow control (after a start bit, ACK or first data bit).	≤ 4 ms
	Normal Ra table data flash updates.	24 ms
	Data flash block writes.	72 ms
	Restored data flash block write after loss of power.	116 ms
	End of discharge Ra table data flash update.	144 ms

9 Application and Implementation

注

Information in the following applications sections is not part of the TI component specification, and TI does not warrant its accuracy or completeness. TI's customers are responsible for determining suitability of components for their purposes. Customers should validate and test their design implementation to confirm system functionality.

9.1 Typical Application



图 6. Schematic

Typical Application (接下页)

9.1.1 Design Requirements

Several key parameters must be updated to align with a given application's battery characteristics. For highest accuracy gauging, it is important to follow-up this initial configuration with a learning cycle to optimize resistance and maximum chemical capacity (Qmax) values prior to sealing and shipping systems to the field. Successful and accurate configuration of the fuel gauge for a target application can be used as the basis for creating a "golden" gas gauge (.fs) file that can be written to all gauges, assuming identical pack design and Li-ion cell origin (chemistry, lot, and so on). Calibration data is included as part of this golden GG file to cut down on system production time. If going this route, it is recommended to average the voltage and current measurement calibration data from a large sample size and use these in the golden file. 表 4, *Key Data Flash Parameters for Configuration*, shows the items that should be configured to achieve reliable protection and accurate gauging with minimal initial configuration.

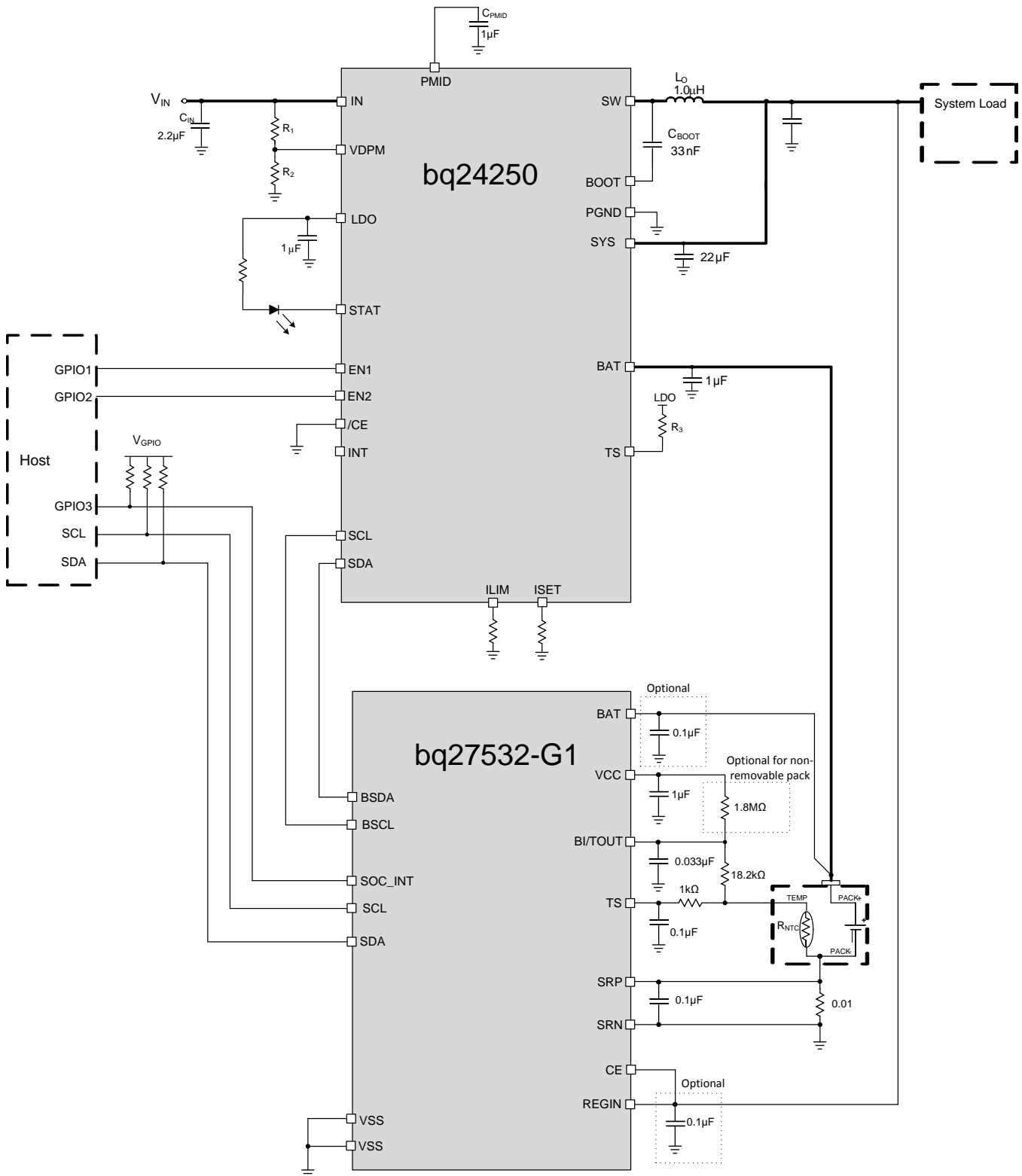
表 4. Key Data Flash Parameters for Configuration

NAME	DEFAULT	UNIT	RECOMMENDED SETTING
Design Capacity	1000	mAh	Set based on the nominal pack capacity as interpreted from cell manufacturer's datasheet. If multiple parallel cells are used, should be set to N x Cell Capacity.
Design Energy Scale	1	-	Set to 10 to convert all power values to cWh or to 1 for mWh. Design Energy is divided by this value.
Reserve Capacity-mAh	0	mAh	Set to desired runtime remaining (in seconds / 3600) x typical applied load between reporting 0% SOC and reaching Terminate Voltage , if needed.
Cycle Count Threshold	900	mAh	Set to 90% of configured Design Capacity .
Chem ID	0100	hex	Should be configured using TI-supplied Battery Management Studio software. Default open-circuit voltage and resistance tables are also updated in conjunction with this step. Do not attempt to manually update reported Device Chemistry as this does not change all chemistry information! Always update chemistry using the appropriate software tool (that is, bqStudio).
Load Mode	1	-	Set to applicable load model, 0 for constant current or 1 for constant power.
Load Select	1	-	Set to load profile which most closely matches typical system load.
Qmax Cell 0	1000	mAh	Set to initial configured value for Design Capacity. The gauge will update this parameter automatically after the optimization cycle and for every regular Qmax update thereafter.
Cell0 V at Chg Term	4200	mV	Set to nominal cell voltage for a fully charged cell. The gauge will update this parameter automatically each time full charge termination is detected.
Terminate Voltage	3200	mV	Set to empty point reference of battery based on system needs. Typical is between 3000 and 3200 mV.
Ra Max Delta	44	mΩ	Set to 15% of Cell0 R_a 4 resistance after an optimization cycle is completed.
Charging Voltage	4200	mV	Set based on nominal charge voltage for the battery in normal conditions (25°C, etc). Used as the reference point for offsetting by Taper Voltage for full charge termination detection.
Taper Current	100	mA	Set to the nominal taper current of the charger + taper current tolerance to ensure that the gauge will reliably detect charge termination.
Taper Voltage	100	mV	Sets the voltage window for qualifying full charge termination. Can be set tighter to avoid or wider to ensure possibility of reporting 100% SOC in outer JEITA temperature ranges that use derated charging voltage.
Dsg Current Threshold	60	mA	Sets threshold for gauge detecting battery discharge. Should be set lower than minimal system load expected in the application and higher than Quit Current .
Chg Current Threshold	75	mA	Sets the threshold for detecting battery charge. Can be set higher or lower depending on typical trickle charge current used. Also should be set higher than Quit Current .
Quit Current	40	mA	Sets threshold for gauge detecting battery relaxation. Can be set higher or lower depending on typical standby current and exhibited in the end system.
Avg I Last Run	-299	mA	Current profile used in capacity simulations at onset of discharge or at all times if Load Select = 0. Should be set to nominal system load. Is automatically updated by the gauge every cycle.
Avg P Last Run	-1131	mW	Power profile used in capacity simulations at onset of discharge or at all times if Load Select = 0. Should be set to nominal system power. Is automatically updated by the gauge every cycle.

Typical Application (接下页)
表 4. Key Data Flash Parameters for Configuration (接下页)

NAME	DEFAULT	UNIT	RECOMMENDED SETTING
Sleep Current	15	mA	Sets the threshold at which the fuel gauge enters SLEEP mode. Take care in setting above typical standby currents else entry to SLEEP may be unintentionally blocked.
Charge T0	0	°C	Sets the boundary between charging inhibit and charging with T0 parameters.
Charge T1	10	°C	Sets the boundary between charging with T0 and T1 parameters.
Charge T2	45	°C	Sets the boundary between charging with T1 and T2 parameters.
Charge T3	50	°C	Sets the boundary between charging with T2 and T3 parameters.
Charge T4	60	°C	Sets the boundary between charging with T3 and T4 parameters.
Charge Current T0	50	% Des Cap	Sets the charge current parameter for T0.
Charge Current T1	50	% Des Cap	Sets the charge current parameter for T1.
Charge Current T2	50	% Des Cap	Sets the charge current parameter for T2.
Charge Current T3	50	% Des Cap	Sets the charge current parameter for T3.
Charge Current T4	0	% Des Cap	Sets the charge current parameter for T4.
Charge Voltage T0	210	20-mV	Sets the charge voltage parameter for T0.
Charge Voltage T1	210	20-mV	Sets the charge voltage parameter for T1.
Charge Voltage T2	207	20-mV	Sets the charge voltage parameter for T2.
Charge Voltage T3	205	20-mV	Sets the charge voltage parameter for T3.
Charge Voltage T4	0	20-mV	Sets the charge voltage parameter for T4.
Chg Temp Hys	5	°C	Adds temperature hysteresis for boundary crossings to avoid oscillation if temperature is changing by a degree or so on a given boundary.
Chg Disabled Regulation V	4200	mV	Sets the voltage threshold for voltage regulation to system when charge is disabled. It is recommended to program to same value as Charging Voltage and maximum charge voltage that is obtained from Charge Voltage Tn parameters.
CC Gain	10	mohms	Calibrate this parameter using TI-supplied bqStudio software and calibration procedure in the TRM. Determines conversion of coulomb counter measured sense resistor voltage to current.
CC Delta	10	mohms	Calibrate this parameter using TI-supplied bqStudio software and calibration procedure in the TRM. Determines conversion of coulomb counter measured sense resistor voltage to passed charge.
CC Offset	-1418	Counts	Calibrate this parameter using TI-supplied bqStudio software and calibration procedure in the TRM. Determines native offset of coulomb counter hardware that should be removed from conversions.
Board Offset	0	Counts	Calibrate this parameter using TI-supplied bqStudio software and calibration procedure in the TRM. Determines native offset of the printed circuit board parasitics that should be removed from conversions.
Pack V Offset	0	mV	Calibrate this parameter using TI-supplied bqStudio software and calibration procedure in the TRM. Determines voltage offset between cell tab and ADC input node to incorporate back into or remove from measurement, depending on polarity.

9.1.2 Detailed Design Procedure
9.1.2.1 BAT Voltage Sense Input

A ceramic capacitor at the input to the BAT pin is used to bypass AC voltage ripple to ground, greatly reducing its influence on battery voltage measurements. It proves most effective in applications with load profiles that exhibit high-frequency current pulses (that is, cell phones) but is recommended for use in all applications to reduce noise on this sensitive high-impedance measurement node.

9.1.2.2 SRP and SRN Current Sense Inputs

The filter network at the input to the coulomb counter is intended to improve differential mode rejection of voltage measured across the sense resistor. These components should be placed as close as possible to the coulomb counter inputs and the routing of the differential traces length-matched to best minimize impedance mismatch-induced measurement errors.

9.1.2.3 Sense Resistor Selection

Any variation encountered in the resistance present between the SRP and SRN pins of the fuel gauge will affect the resulting differential voltage, and derived current, it senses. As such, it is recommended to select a sense resistor with minimal tolerance and temperature coefficient of resistance (TCR) characteristics. The standard recommendation based on best compromise between performance and price is a 1% tolerance, 100 ppm drift sense resistor with a 1-W power rating.

9.1.2.4 TS Temperature Sense Input

Similar to the BAT pin, a ceramic decoupling capacitor for the TS pin is used to bypass AC voltage ripple away from the high-impedance ADC input, minimizing measurement error. Another helpful advantage is that the capacitor provides additional ESD protection since the TS input to system may be accessible in systems that use removable battery packs. It should be placed as close as possible to the respective input pin for optimal filtering performance.

9.1.2.5 Thermistor Selection

The fuel gauge temperature sensing circuitry is designed to work with a negative temperature coefficient-type (NTC) thermistor with a characteristic 10-k Ω resistance at room temperature (25°C). The default curve-fitting coefficients configured in the fuel gauge specifically assume a 103AT-2 type thermistor profile and so that is the default recommendation for thermistor selection purposes. Moving to a separate thermistor resistance profile (for example, JT-2 or others) requires an update to the default thermistor coefficients in data flash to ensure highest accuracy temperature measurement performance.

9.1.2.6 RGIN Power Supply Input Filtering

A ceramic capacitor is placed at the input to the fuel gauge internal LDO to increase power supply rejection (PSR) and improve effective line regulation. It ensures that voltage ripple is rejected to ground instead of coupling into the internal supply rails of the fuel gauge.

9.1.2.7 V_{CC} LDO Output Filtering

A ceramic capacitor is also needed at the output of the internal LDO to provide a current reservoir for fuel gauge load peaks during high peripheral utilization. It acts to stabilize the regulator output and reduce core voltage ripple inside of the fuel gauge.

10 Power Supply Recommendations

10.1 Power Supply Decoupling

Both the RGIN input pin and the V_{CC} output pin require low equivalent series resistance (ESR) ceramic capacitors placed as closely as possible to the respective pins to optimize ripple rejection and provide a stable and dependable power rail that is resilient to line transients. A 0.1- μ F capacitor at the RGIN and a 1- μ F capacitor at V_{CC} will suffice for satisfactory device performance.

11 Layout

11.1 Layout Guidelines

11.1.1 Sense Resistor Connections

Kelvin connections at the sense resistor are just as critical as those for the battery terminals themselves. The differential traces should be connected at the inside of the sense resistor pads and not anywhere along the high-current trace path to prevent false increases to measured current that could result when measuring between the sum of the sense resistor and trace resistance between the tap points. In addition, the routing of these leads from the sense resistor to the input filter network and finally into the SRP and SRN pins needs to be as closely matched in length as possible else additional measurement offset could occur. It is further recommended to add copper trace or pour-based "guard rings" around the perimeter of the filter network and coulomb counter inputs to shield these sensitive pins from radiated EMI into the sense nodes. This prevents differential voltage shifts that could be interpreted as real current change to the fuel gauge. All of the filter components need to be placed as close as possible to the coulomb counter input pins.

11.1.2 Thermistor Connections

The thermistor sense input should include a ceramic bypass capacitor placed as close to the TS input pin as possible. The capacitor helps to filter measurements of any stray transients as the voltage bias circuit pulses periodically during temperature sensing windows.

11.1.3 High-Current and Low-Current Path Separation

For best possible noise performance, it is extremely important to separate the low-current and high-current loops to different areas of the board layout. The fuel gauge and all support components should be situated on one side of the boards and tap off of the high-current loop (for measurement purposes) at the sense resistor. Routing the low-current ground around instead of under high-current traces will further help to improve noise rejection.

12 器件和文档支持

12.1 文档支持

12.1.1 相关文档

如需以下任何 TI 文档的副本，请致电 (800) 477-8924 联系德州仪器 (TI) 文献咨询中心或致电 (512) 434-1560 联系支持中心。订购时，可通过文档标题或文献编号识别文档。也可通过 TI 网站获取更新版本的文档，网址：www.ti.com。

1. 《bq27532-G1 技术参考手册用户指南》(SLUUB04)
2. 《bq27532EVM, 带 bq27532 电池管理单元 Track™ 电量监测计和 bq24250 2.0A, 适用于单节应用的开关模式电池充电器用户指南》(SLUUB58)

12.2 商标

Impedance Track, NanoFree are trademarks of Texas Instruments.

All other trademarks are the property of their respective owners.

12.3 静电放电警告



ESD 可能会损坏该集成电路。德州仪器 (TI) 建议通过适当的预防措施处理所有集成电路。如果不遵守正确的处理措施和安装程序，可能会损坏集成电路。

ESD 的损坏小至导致微小的性能降级，大至整个器件故障。精密的集成电路可能更容易受到损坏，这是因为非常细微的参数更改都可能会导致器件与其发布的规格不相符。

12.4 术语表

[SLYZ022](#) — TI 术语表。

这份术语表列出并解释术语、首字母缩略词和定义。

13 机械封装和可订购信息

以下页中包括机械封装和可订购信息。 这些信息是针对指定器件可提供的最新数据。 这些数据会在无通知且不对本文档进行修订的情况下发生改变。 欲获得该数据表的浏览器版本，请查阅左侧的导航栏。

PACKAGING INFORMATION

Orderable Device	Status (1)	Package Type	Package Drawing	Pins	Package Qty	Eco Plan (2)	Lead finish/ Ball material (6)	MSL Peak Temp (3)	Op Temp (°C)	Device Marking (4/5)	Samples
BQ27532YZFR-G1	ACTIVE	DSBGA	YZF	15	3000	RoHS & Green	SNAGCU	Level-1-260C-UNLIM	-40 to 85	BQ27532	Samples
BQ27532YZFT-G1	ACTIVE	DSBGA	YZF	15	250	RoHS & Green	SNAGCU	Level-1-260C-UNLIM	-40 to 85	BQ27532	Samples

(1) The marketing status values are defined as follows:

ACTIVE: Product device recommended for new designs.

LIFEBUY: TI has announced that the device will be discontinued, and a lifetime-buy period is in effect.

NRND: Not recommended for new designs. Device is in production to support existing customers, but TI does not recommend using this part in a new design.

PREVIEW: Device has been announced but is not in production. Samples may or may not be available.

OBSELETE: TI has discontinued the production of the device.

(2) **RoHS:** TI defines "RoHS" to mean semiconductor products that are compliant with the current EU RoHS requirements for all 10 RoHS substances, including the requirement that RoHS substance do not exceed 0.1% by weight in homogeneous materials. Where designed to be soldered at high temperatures, "RoHS" products are suitable for use in specified lead-free processes. TI may reference these types of products as "Pb-Free".

RoHS Exempt: TI defines "RoHS Exempt" to mean products that contain lead but are compliant with EU RoHS pursuant to a specific EU RoHS exemption.

Green: TI defines "Green" to mean the content of Chlorine (Cl) and Bromine (Br) based flame retardants meet JS709B low halogen requirements of <=1000ppm threshold. Antimony trioxide based flame retardants must also meet the <=1000ppm threshold requirement.

(3) MSL, Peak Temp. - The Moisture Sensitivity Level rating according to the JEDEC industry standard classifications, and peak solder temperature.

(4) There may be additional marking, which relates to the logo, the lot trace code information, or the environmental category on the device.

(5) Multiple Device Markings will be inside parentheses. Only one Device Marking contained in parentheses and separated by a "~" will appear on a device. If a line is indented then it is a continuation of the previous line and the two combined represent the entire Device Marking for that device.

(6) Lead finish/Ball material - Orderable Devices may have multiple material finish options. Finish options are separated by a vertical ruled line. Lead finish/Ball material values may wrap to two lines if the finish value exceeds the maximum column width.

Important Information and Disclaimer:The information provided on this page represents TI's knowledge and belief as of the date that it is provided. TI bases its knowledge and belief on information provided by third parties, and makes no representation or warranty as to the accuracy of such information. Efforts are underway to better integrate information from third parties. TI has taken and continues to take reasonable steps to provide representative and accurate information but may not have conducted destructive testing or chemical analysis on incoming materials and chemicals. TI and TI suppliers consider certain information to be proprietary, and thus CAS numbers and other limited information may not be available for release.

In no event shall TI's liability arising out of such information exceed the total purchase price of the TI part(s) at issue in this document sold by TI to Customer on an annual basis.

YZF0015

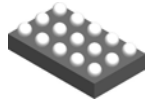

PACKAGE OUTLINE

DSBGA - 0.625 mm max height

DIE SIZE BALL GRID ARRAY

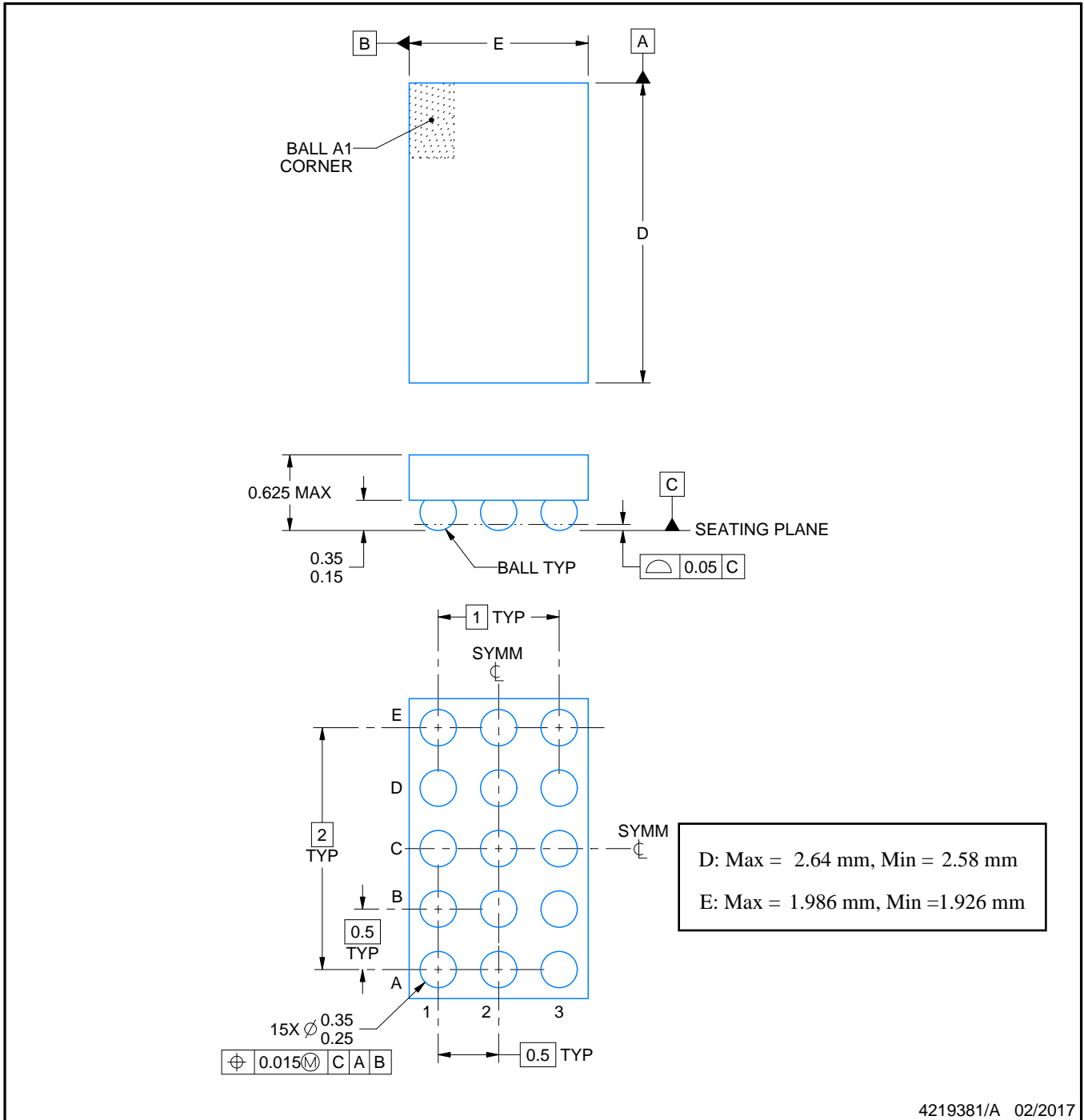

NOTES:

NanoFree is a trademark of Texas Instruments.

1. All linear dimensions are in millimeters. Any dimensions in parenthesis are for reference only. Dimensioning and tolerancing per ASME Y14.5M.
2. This drawing is subject to change without notice.
3. NanoFree™ package configuration.

EXAMPLE BOARD LAYOUT

YZF0015

DSBGA - 0.625 mm max height

DIE SIZE BALL GRID ARRAY

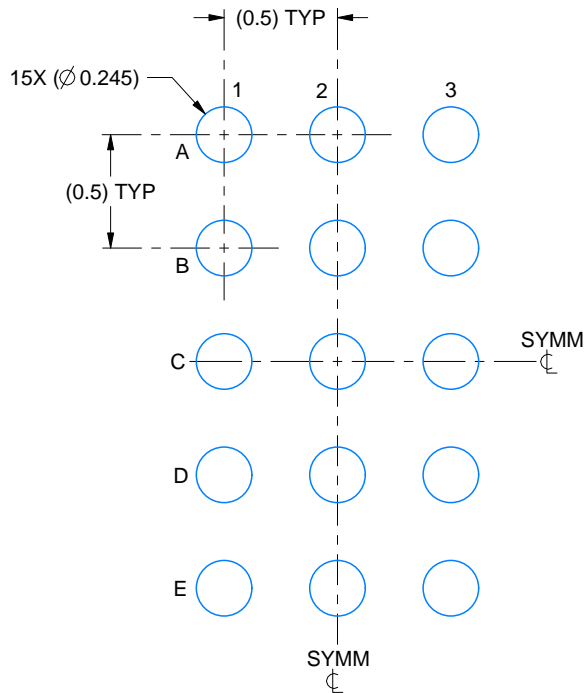

LAND PATTERN EXAMPLE
EXPOSED METAL SHOWN
SCALE:30X

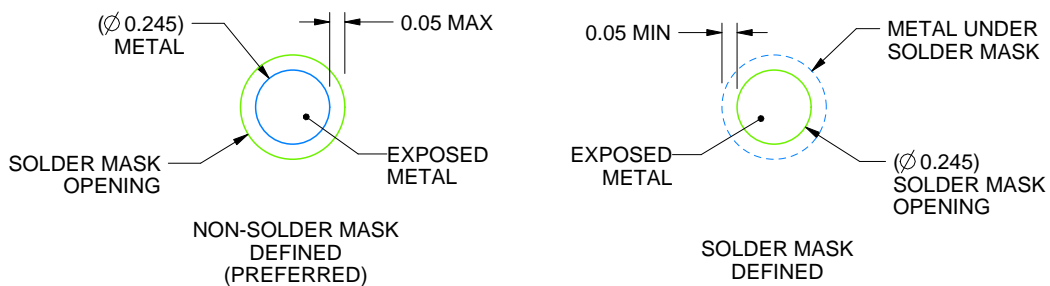

SOLDER MASK DETAILS
NOT TO SCALE

4219381/A 02/2017

NOTES: (continued)

- Final dimensions may vary due to manufacturing tolerance considerations and also routing constraints. For more information, see Texas Instruments literature number SNVA009 (www.ti.com/lit/snva009).

EXAMPLE STENCIL DESIGN

YZF0015

DSBGA - 0.625 mm max height

DIE SIZE BALL GRID ARRAY

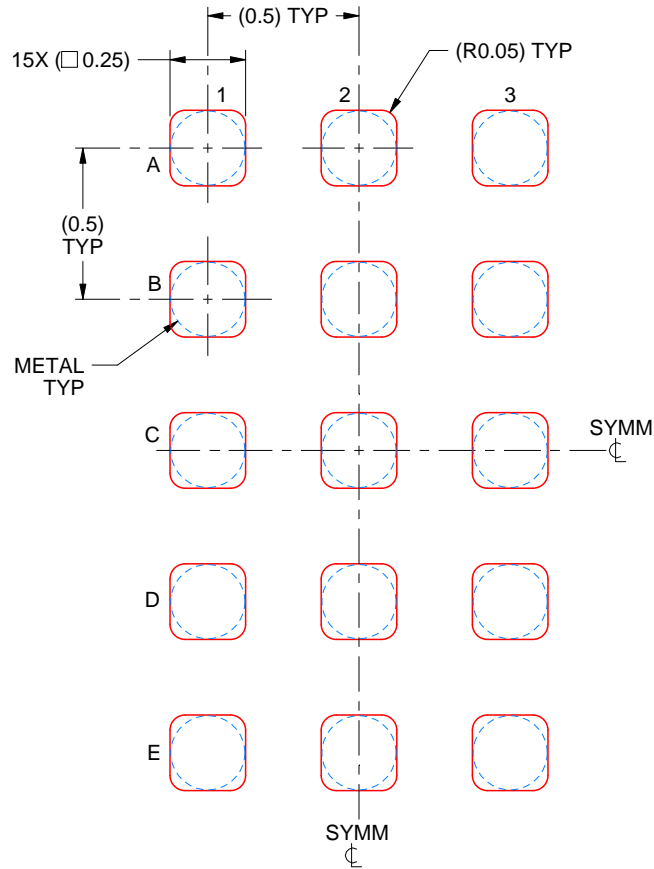

SOLDER PASTE EXAMPLE
BASED ON 0.1 mm THICK STENCIL
SCALE:40X

4219381/A 02/2017

NOTES: (continued)

5. Laser cutting apertures with trapezoidal walls and rounded corners may offer better paste release.

重要声明和免责声明

TI“按原样”提供技术和可靠性数据（包括数据表）、设计资源（包括参考设计）、应用或其他设计建议、网络工具、安全信息和其他资源，不保证没有瑕疵且不做任何明示或暗示的担保，包括但不限于对适销性、某特定用途方面的适用性或不侵犯任何第三方知识产权的暗示担保。

这些资源可供使用 TI 产品进行设计的熟练开发人员使用。您将自行承担以下全部责任：(1) 针对您的应用选择合适的 TI 产品，(2) 设计、验证并测试您的应用，(3) 确保您的应用满足相应标准以及任何其他功能安全、信息安全、监管或其他要求。

这些资源如有变更，恕不另行通知。TI 授权您仅可将这些资源用于研发本资源所述的 TI 产品的应用。严禁对这些资源进行其他复制或展示。您无权使用任何其他 TI 知识产权或任何第三方知识产权。您应全额赔偿因在这些资源的使用中对 TI 及其代表造成的任何索赔、损害、成本、损失和债务，TI 对此概不负责。

TI 提供的产品受 [TI 的销售条款](#) 或 [ti.com](#) 上其他适用条款/TI 产品随附的其他适用条款的约束。TI 提供这些资源并不会扩展或以其他方式更改 TI 针对 TI 产品发布的适用的担保或担保免责声明。

TI 反对并拒绝您可能提出的任何其他或不同的条款。

邮寄地址：Texas Instruments, Post Office Box 655303, Dallas, Texas 75265

Copyright © 2022，德州仪器 (TI) 公司