

LM4041 精密低功耗并联电压基准

1 特性

- 具有 1.225V 固定输出电压和可调输出电压 (1.225V 至 10V)
- 严格输出容差和低温度系数
 - 0.1% (最大值), 100ppm/°C - A 级
 - 0.2% (最大值), 100ppm/°C - B 级
 - 0.5% (最大值), 100ppm/°C - C 级
 - 1.0% (最大值), 150ppm/°C - D 级
- 低输出噪声 ...20 μ V_{RMS} (典型值)
- 宽工作电流范围 ...
45 μ A (典型值) 至 12mA
- 与所有容性负载一起工作时保持稳定 ; 无需输出电容器
- 可采用
 - 工业温度 : -40°C 至 85°C
 - 工作温度范围 : -40°C 至 125°C

2 应用

- 数据采集系统
- 电源和电源监控器
- 仪表和测试设备
- 过程控制
- 精密音频
- 汽车电子产品
- 能源管理/计量
- 电池供电设备

3 说明

LM4041 系列并联电压基准功能多样、易于使用, 适合各种应用。这些器件无需外部电容器即可运行, 与所有容性负载一起工作时均保持稳定。此外, 该基准具备低动态阻抗、低噪声和低温度系数, 可确保在宽工作电流和温度范围内实现稳定的输出电压。LM4041 在晶圆筛选期间使用保险丝和齐纳击穿反向击穿电压修整, 以提供四种输出电压容差 - 从最高 0.1% (A 级) 到最高 1% (D 级)。这样设计人员可以非常灵活地为应用选择具有高性价比的产品。LM4041 可提供固定电压 (1.225V 标称值) 或可调电压版本 (需要外部电阻分压器将输出设为 1.225V 至 10V 间的任意值)。

LM4041 采用节省空间的 SC-70 和 SOT-23-3 封装, 最低电流为 45 μ A (典型值), 也适用于便携式应用。如需穿孔封装, 我们还提供 TO-92 封装。LM4041xI 的额定工作环境温度范围是 - 40°C 至 85°C。LM4041xQ 的额定工作环境温度范围是 - 40°C 至 125°C。



4 Pin Configuration and Functions



图 4-1. DBZ Package 3-Pin SOT-23 Top View



图 4-2. DCK Package 5-Pin SC70 Top View

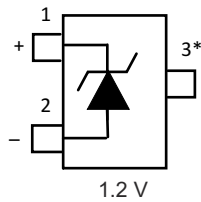

图 4-3. LP Package 3-Pin TO-92 Bottom View

Pin Functions

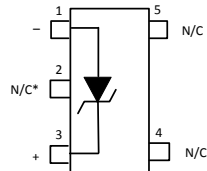
NAME	PIN			I/O	DESCRIPTION
	SOT-23	SC70	TO-92		
Anode	2	1	1	O	Anode pin, normally grounded
Cathode	1	3	2	I/O	Shunt current and output voltage
FB	—	—	—	I	Feedback pin for adjustable output voltage
NC*	3	2	3	—	**Must float or connect to anode
NC	—	4, 5	—	—	No connect

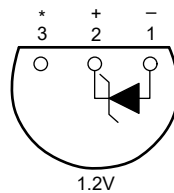

图 4-4. DBZ Package 3-Pin SOT-23 Top View



图 4-5. DCK Package 5-Pin SC70 Top View

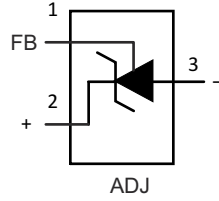

图 4-6. LP Package 3-Pin TO-92 Bottom View

Pin Functions: ADJ Pinouts

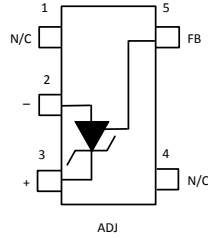
NAME	PIN			I/O	DESCRIPTION
	SOT-23	SC70	TO-92		
Anode	3	2	1	O	Anode pin, normally grounded
Cathode	2	3	2	I/O	Shunt current and output voltage
FB	1	5	3	I	Feedback pin for adjustable output voltage
NC**	—	—	—	—	**Must float or connect to anode
NC	—	1, 4	—	—	No connect

5 Functional Block Diagram

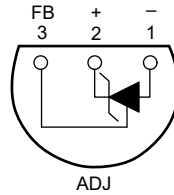

图 5-1. Functional Block Diagram

6 Specifications

6.1 Absolute Maximum Ratings

over free-air temperature range (unless otherwise noted)

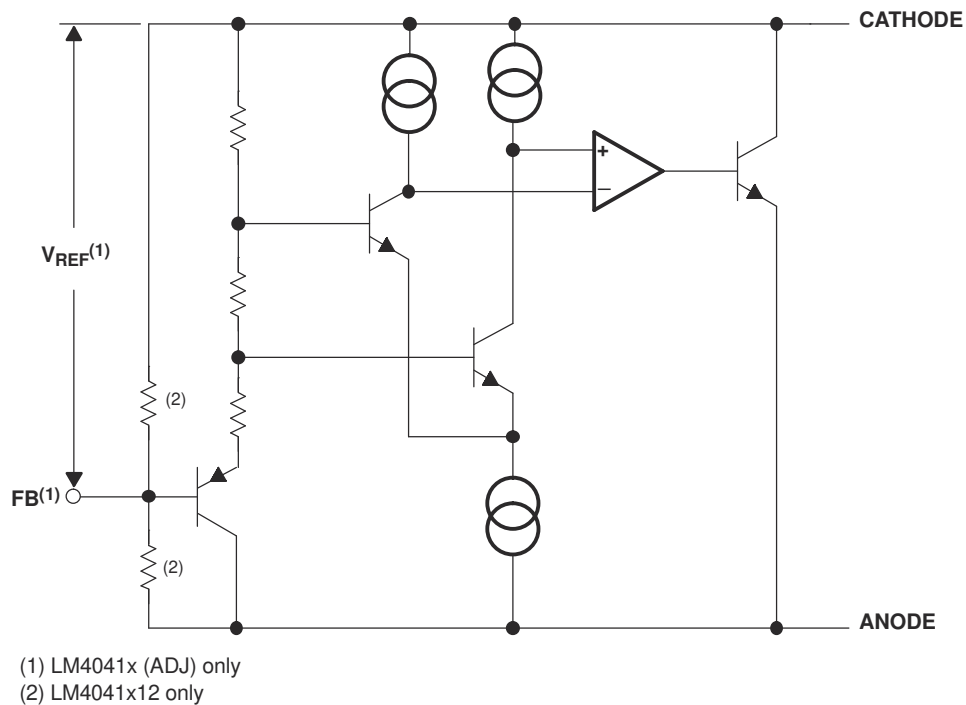
		MIN	MAX ⁽¹⁾	UNIT
V_Z	Continuous cathode voltage		15	V
I_Z	Continuous cathode current	- 10	25	mA
θ_{JA}	Package thermal impedance ^{(2) (3)}	DBZ package	206	°C/W
		DCK package	252	
		LP package	156	
T_J	Operating virtual junction temperature		150	°C
T_{stg}	Storage temperature range	- 65	150	°C

- (1) Stresses beyond those listed under "absolute maximum ratings" may cause permanent damage to the device. These are stress ratings only, and functional operation of the device at these or any other conditions beyond those indicated under "recommended operating conditions" is not implied. Exposure to absolute-maximum-rated conditions for extended periods may affect device reliability.
- (2) Maximum power dissipation is a function of $T_J(\text{max})$, θ_{JA} , and T_A . The maximum allowable power dissipation at any allowable ambient temperature is $P_D = (T_J(\text{max}) - T_A) / \theta_{JA}$. Operating at the absolute maximum T_J of 150°C can affect reliability.
- (3) The package thermal impedance is calculated in accordance with JESD 51-7.

6.2 Recommended Operating Conditions

		MIN	MAX	UNIT	
I_Z	Cathode current	(1)	12	mA	
V_Z	Reverse breakdown voltage (adjustable version)		10	V	
T_A	Free-air temperature	LM4041 (I temperature)	- 40	85	°C
		LM4041 (Q temperature)	- 40	125	

(1) See parametric tables

6.3 LM4041x12I Electrical Characteristics

full-range $T_A = -40^\circ\text{C}$ to 85°C (unless otherwise noted)

PARAMETER	TEST CONDITIONS	T_A	LM4041A12I			LM4041B12I			UNIT
			MIN	TYP	MAX	MIN	TYP	MAX	
V_Z	Reverse breakdown voltage	$I_Z = 100\ \mu\text{A}$	1.225			1.225			V
	Reverse breakdown voltage tolerance	$I_Z = 100\ \mu\text{A}$	25°C	- 1.2	1.2	- 2.4	2.4	mV	
			Full range	- 9.2	9.2	- 10.4	10.4		
$I_{Z,\text{min}}$	Minimum cathode current		25°C	45	75	45	75	μA	
			Full range	80		80			
α_{V_Z}	Average temperature coefficient of reverse breakdown voltage	$I_Z = 10\text{mA}$	25°C	± 20		± 20		ppm/°C	
		$I_Z = 1\text{mA}$	25°C	± 15		± 15			
			Full range	± 100		± 100			
		$I_Z = 100\ \mu\text{A}$	25°C	± 15		± 15			
$\frac{\Delta V_Z}{\Delta I_Z}$	Reverse breakdown voltage change with cathode current change	$I_{Z,\text{min}} < I_Z < 1\text{mA}$	25°C	0.7	1.5	0.7	1.5	mV	
			Full range	2		2			
		$1\text{mA} < I_Z < 12\text{mA}$	25°C	4	6	4	6		
			Full range	8		8			
Z_Z	Reverse dynamic impedance	$I_Z = 1\text{mA}$, $f = 120\text{Hz}$, $I_{AC} = 0.1 I_Z$	25°C	0.5	1.5	0.5	1.5	Ω	
e_N	Wideband noise	$I_Z = 100\ \mu\text{A}$, $10\text{Hz} \leq f \leq 10\text{kHz}$	25°C	20		20		μV_{RMS}	
	Long-term stability of reverse breakdown voltage	$t = 1000\text{h}$, $T_A = 25^\circ\text{C} \pm 0.1^\circ\text{C}$, $I_Z = 100\ \mu\text{A}$	25°C	120		120		ppm	

6.4 LM4041x12I Electrical Characteristics

full-range $T_A = -40^\circ\text{C}$ to 85°C (unless otherwise noted)

PARAMETER	TEST CONDITIONS	T_A	LM4041C12I			LM4041D12I			UNIT	
			MIN	TYP	MAX	MIN	TYP	MAX		
V_Z	Reverse breakdown voltage	$I_Z = 100\ \mu\text{A}$	1.225			1.225			V	
	Reverse breakdown voltage tolerance	$I_Z = 100\ \mu\text{A}$	25°C		-6	6	-12		12	mV
			Full range		-14	14	-24		24	
$I_{Z,\text{min}}$	Minimum cathode current		25°C		45	75	45		75	μA
			Full range		80		80			
α_{V_Z}	Average temperature coefficient of reverse breakdown voltage	$I_Z = 10\text{mA}$	25°C		± 20		± 20		ppm/°C	
		$I_Z = 1\text{mA}$	25°C		± 15		± 15			
			Full range		± 100		± 150			
$\frac{\Delta V_Z}{\Delta I_Z}$	Reverse breakdown voltage change with cathode current change	$I_{Z,\text{min}} < I_Z < 1\text{mA}$	25°C		0.7	1.5	0.7		2	mV
			Full range		2		2.5			
		$1\text{mA} < I_Z < 12\text{mA}$	25°C		2.5	6	2.5		8	
			Full range		8		10			
Z_Z	Reverse dynamic impedance	$I_Z = 1\text{mA}$, $f = 120\text{Hz}$, $I_{AC} = 0.1 I_Z$	25°C		0.5	1.5	0.5		2	Ω
e_N	Wideband noise	$I_Z = 100\ \mu\text{A}$, $10\text{Hz} \leq f \leq 10\text{kHz}$	25°C		20		20		μV_{RMS}	
	Long-term stability of reverse breakdown voltage	$t = 1000\text{h}$, $T_A = 25^\circ\text{C} \pm 0.1^\circ\text{C}$, $I_Z = 100\ \mu\text{A}$	25°C		120		120		ppm	

6.5 LM4041x12Q Electrical Characteristics

full-range $T_A = -40^\circ\text{C}$ to 125°C (unless otherwise noted)

PARAMETER	TEST CONDITIONS	T_A	LM4041C12Q			LM4041D12Q			UNIT
			MIN	TYP	MAX	MIN	TYP	MAX	
V_Z	Reverse breakdown voltage	$I_Z = 100 \mu\text{A}$	25°C			1.225			V
	Reverse breakdown voltage tolerance	$I_Z = 100 \mu\text{A}$	25°C			- 6 6			mV
			Full range			- 18.4 18.4			
$I_{Z,\text{min}}$	Minimum cathode current		25°C			45 75			μA
			Full range			80 80			
α_{V_Z}	Average temperature coefficient of reverse breakdown voltage	$I_Z = 10\text{mA}$	25°C			± 20			ppm/°C
		$I_Z = 1\text{mA}$	25°C			± 15			
			Full range			± 100			
$\frac{\Delta V_Z}{\Delta I_Z}$	Reverse breakdown voltage change with cathode current change	$I_{Z,\text{min}} < I_Z < 1\text{mA}$	25°C			0.7 1.5			mV
			Full range			2 2.5			
		$1\text{mA} < I_Z < 12\text{mA}$	25°C			2.5 6			
			Full range			8 10			
Z_Z	Reverse dynamic impedance	$I_Z = 1\text{mA}$, $f = 120\text{Hz}$, $I_{AC} = 0.1 I_Z$	25°C			0.5			Ω
			Full range			1.5 2			
e_N	Wideband noise	$I_Z = 100 \mu\text{A}$, $10\text{Hz} \leq f \leq 10\text{kHz}$	25°C			20			μV_{RMS}
	Long-term stability of reverse breakdown voltage	$t = 1000\text{h}$, $T_A = 25^\circ\text{C} \pm 0.1^\circ\text{C}$, $I_Z = 100 \mu\text{A}$	25°C			120			ppm

6.6 LM4041xl (Adjustable Version) Electrical Characteristics

full-range $T_A = -40^\circ\text{C}$ to 85°C (unless otherwise noted)

PARAMETER	TEST CONDITIONS	T_A	LM4041BI			LM4041CI			UNIT	
			MIN	TYP	MAX	MIN	TYP	MAX		
V_{REF}	Reference voltage	$I_Z = 100\ \mu\text{A}$, $V_Z = 5\text{V}$	25°C			1.233			V	
	Reference voltage tolerance ⁽¹⁾	$I_Z = 100\ \mu\text{A}$, $V_Z = 5\text{V}$	25°C			-2.5	2.5	-6.2	6.2	mV
			Full range			-10.5	10.5	-14	14	
$I_{Z,min}$	Minimum cathode current		25°C			45	75	45	75	μA
			Full range				80		80	
$\Delta V_{REF}/\Delta I_Z$	Reference voltage change with cathode current change	$I_{Z,min} < I_Z < 1\text{mA}$	25°C			0.7	1.5	0.7	1.5	mV
			Full range				2		2	
		$1\text{mA} < I_Z < 12\text{mA}$	25°C			2	4	2	4	
			Full range				6		6	
$\Delta V_{REF}/\Delta V_{KA}$	Reference voltage change with output voltage change	$I_Z = 1\text{mA}$	25°C			-1.55	-2	-1.55	-2	mV/V
			Full range				-2.5		-2.5	
I_{FB}	Feedback current		25°C			60	100	60	100	nA
			Full range				120		120	
αV_{REF}	Average temperature coefficient of reference voltage ⁽¹⁾	$I_Z = 10\text{mA}$, $V_Z = 5\text{V}$	25°C			± 20			ppm/°C	
		$I_Z = 1\text{mA}$, $V_Z = 5\text{V}$	25°C			± 15				
			Full range			± 100				
		$I_Z = 100\ \mu\text{A}$, $V_Z = 5\text{V}$	25°C			± 15				
Z_Z	Reverse dynamic impedance	$I_Z = 1\text{mA}$, $f = 120\text{Hz}$, $I_{AC} = 0.1 I_Z$, $V_Z = V_{REF}$	25°C			0.3			Ω	
		$I_Z = 1\text{mA}$, $f = 120\text{Hz}$, $I_{AC} = 0.1 I_Z$, $V_Z = 10\text{V}$	25°C			2				
e_N	Wideband noise	$I_Z = 100\ \mu\text{A}$, $V_Z = V_{REF}$, $10\text{Hz} \leq f \leq 10\text{kHz}$	25°C			20			μV_{RMS}	
	Long-term stability of reverse breakdown voltage	$t = 1000\text{ h}$, $T_A = 25^\circ\text{C} \pm 0.1^\circ\text{C}$, $I_Z = 100\ \mu\text{A}$	25°C			120			ppm	

(1) Reference voltage tolerance and average temperature coefficient change with output voltage (V_Z). See *Typical Characteristics*.

6.7 LM4041xl (Adjustable Version) Electrical Characteristics

full-range $T_A = -40^\circ\text{C}$ to 85°C (unless otherwise noted)

PARAMETER	TEST CONDITIONS	T_A	LM4041DI			UNIT
			MIN	TYP	MAX	
V_{REF}	Reference voltage	$I_Z = 100\ \mu\text{A}$, $V_Z = 5\text{V}$	25°C	1.233		V
	Reference voltage tolerance ⁽¹⁾	$I_Z = 100\ \mu\text{A}$, $V_Z = 5\text{V}$	25°C	- 12	12	mV
			Full range	- 24	24	
$I_{Z,\text{min}}$	Minimum cathode current		25°C	45	75	μA
			Full range		80	
$\Delta V_{REF}/\Delta I_Z$	Reference voltage change with cathode current change	$I_{Z,\text{min}} < I_Z < 1\text{mA}$	25°C	0.7	2	mV
			Full range		2.5	
		$1\text{mA} < I_Z < 12\text{mA}$	25°C	2	6	
			Full range		8	
$\Delta V_{REF}/\Delta V_{KA}$	Reference voltage change with output voltage change	$I_Z = 1\text{mA}$	25°C	- 1.55	- 2	mV/V
			Full range		- 3	
I_{FB}	Feedback current		25°C	60	150	nA
			Full range		200	
αV_{REF}	Average temperature coefficient of reference voltage ⁽¹⁾	$I_Z = 10\text{mA}$, $V_Z = 5\text{V}$	25°C	± 20	ppm/ $^\circ\text{C}$	
			25°C	± 15		
		$I_Z = 1\text{mA}$, $V_Z = 5\text{V}$	Full range	± 150		
			25°C	± 15		
Z_Z	Reverse dynamic impedance	$I_Z = 1\text{mA}$, $f = 120\text{Hz}$, $I_{AC} = 0.1 I_Z$, $V_Z = V_{REF}$	25°C	0.3	Ω	
			25°C	2		
e_N	Wideband noise	$I_Z = 100\ \mu\text{A}$, $V_Z = V_{REF}$, $10\text{Hz} \leq f \leq 10\text{kHz}$	25°C	20	μV_{RMS}	
	Long-term stability of reverse breakdown voltage	$t = 1000\text{ h}$, $T_A = 25^\circ\text{C} \pm 0.1^\circ\text{C}$, $I_Z = 100\ \mu\text{A}$	25°C	120	ppm	

(1) Reference voltage tolerance and average temperature coefficient change with output voltage (V_Z). See *Typical Characteristics*.

6.8 LM4041xQ (Adjustable Version) Electrical Characteristics

full-range $T_A = -40^\circ\text{C}$ to 125°C (unless otherwise noted)

PARAMETER	TEST CONDITIONS	T_A	LM4041CQ			LM4041DQ			UNIT			
			MIN	TYP	MAX	MIN	TYP	MAX				
V_{REF}	Reference voltage	$I_Z = 100\ \mu\text{A}$, $V_Z = 5\text{V}$	25°C			1.233			V			
	Reference voltage tolerance ⁽¹⁾	$I_Z = 100\ \mu\text{A}$, $V_Z = 5\text{V}$	25°C			-6.2	6.2		-12	12	mV	
			Full range			-18	18		-30	30		
$I_{Z,min}$	Minimum cathode current		25°C			45		45		75	μA	
			Full range			80			80			
$\Delta V_{REF}/\Delta I_Z$	Reference voltage change with cathode current change	$I_{Z,min} < I_Z < 1\text{mA}$	25°C			0.7	1.5		0.7	2	mV	
			Full range			2			2.5			
		$1\text{mA} < I_Z < 12\text{mA}$	25°C			2		4		2		6
			Full range			8			10			
$\Delta V_{REF}/\Delta V_{KA}$	Reference voltage change with output voltage change	$I_Z = 1\text{mA}$	25°C			-1.55	-2		-1.55	-2.5	mV/V	
			Full range			-3			-4			
I_{FB}	Feedback current		25°C			60	100		60	150	nA	
			Full range			120			200			
αV_{REF}	Average temperature coefficient of reference voltage ⁽¹⁾	$I_Z = 10\text{mA}$, $V_Z = 5\text{V}$	25°C			± 20			± 20	ppm/°C		
		$I_Z = 1\text{mA}$, $V_Z = 5\text{V}$	25°C			± 15			± 15			
			Full range			± 100			± 150			
		$I_Z = 100\ \mu\text{A}$, $V_Z = 5\text{V}$	25°C			± 15			± 15			
Z_Z	Reverse dynamic impedance	$I_Z = 1\text{mA}$, $f = 120\text{Hz}$, $I_{AC} = 0.1 I_Z$, $V_Z = V_{REF}$	25°C			0.3			0.3	Ω		
		$I_Z = 1\text{mA}$, $f = 120\text{Hz}$, $I_{AC} = 0.1 I_Z$, $V_Z = 10\text{V}$	25°C			2			2			
e_N	Wideband noise	$I_Z = 100\ \mu\text{A}$, $V_Z = V_{REF}$, $10\text{Hz} \leq f \leq 10\text{kHz}$	25°C			20			20	μV_{RMS}		
	Long-term stability of reverse breakdown voltage	$t = 1000\text{ h}$, $T_A = 25^\circ\text{C} \pm 0.1^\circ\text{C}$, $I_Z = 100\ \mu\text{A}$	25°C			120			120	ppm		

(1) Reference voltage tolerance and average temperature coefficient change with output voltage (V_Z). See *Typical Characteristics*.

6.9 Typical Characteristics



图 6-1. Temperature Drift for Different Average Temperature Coefficients



图 6-2. Noise Voltage vs Frequency

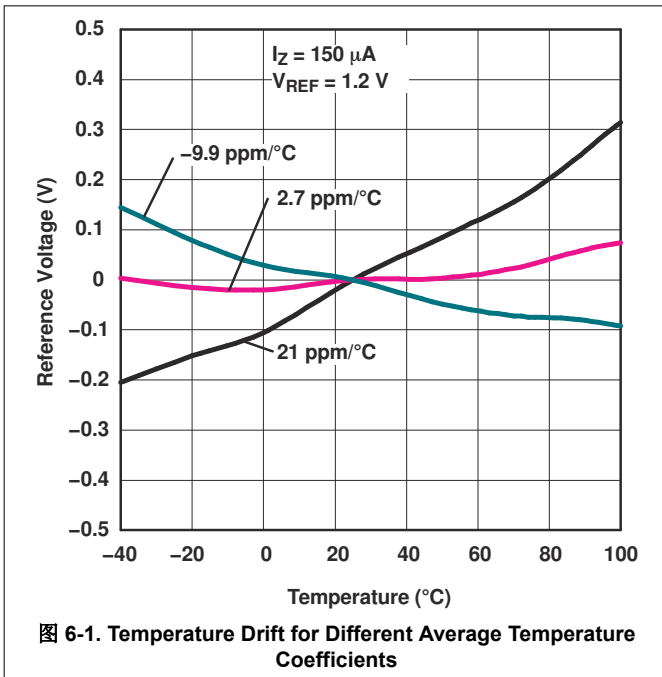

图 6-3. Start-Up Characteristics

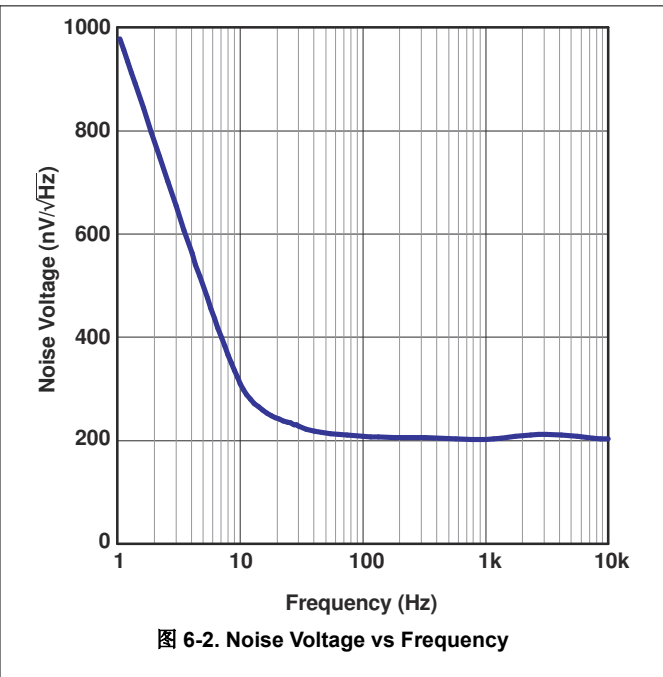

图 6-4. Reference Voltage vs Reverse (Output) Voltage (for Different Temperatures)

6.9 Typical Characteristics (continued)

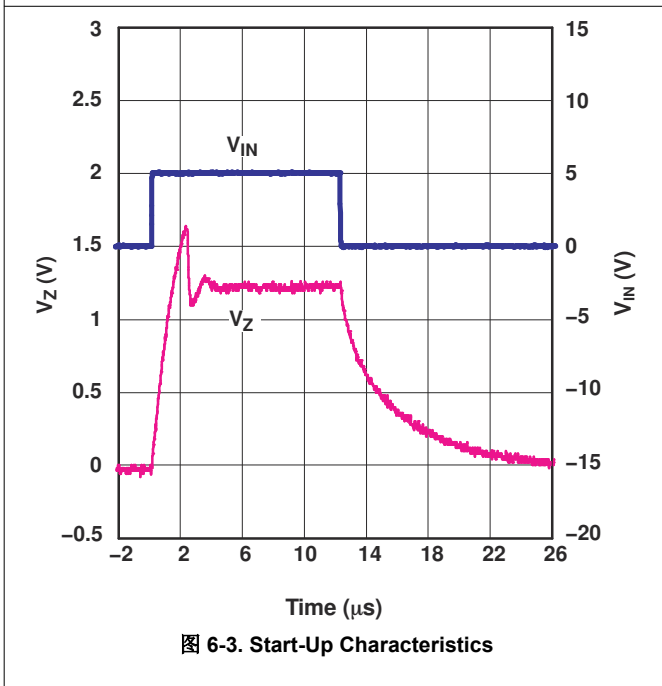

图 6-5. Reference Voltage vs Temperature (for Different Reverse Voltages)

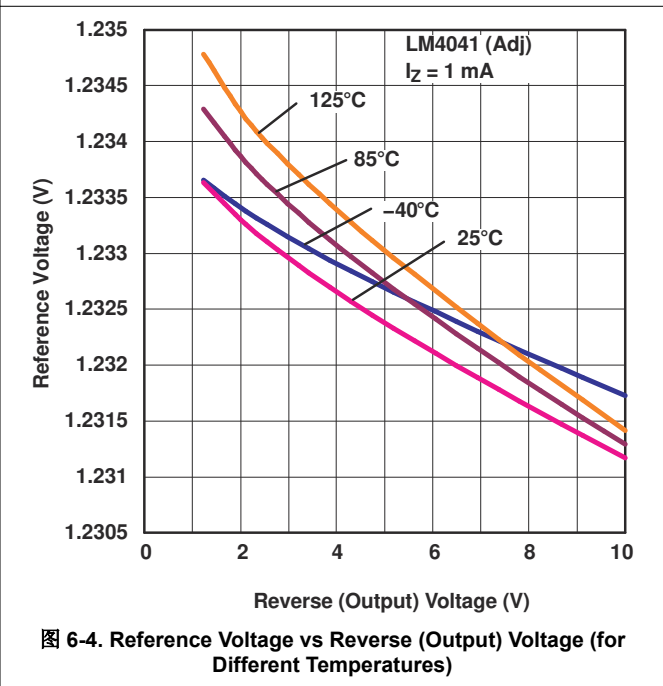

图 6-6. Feedback Current vs Reverse (Output) Voltage (for Different Temperatures)

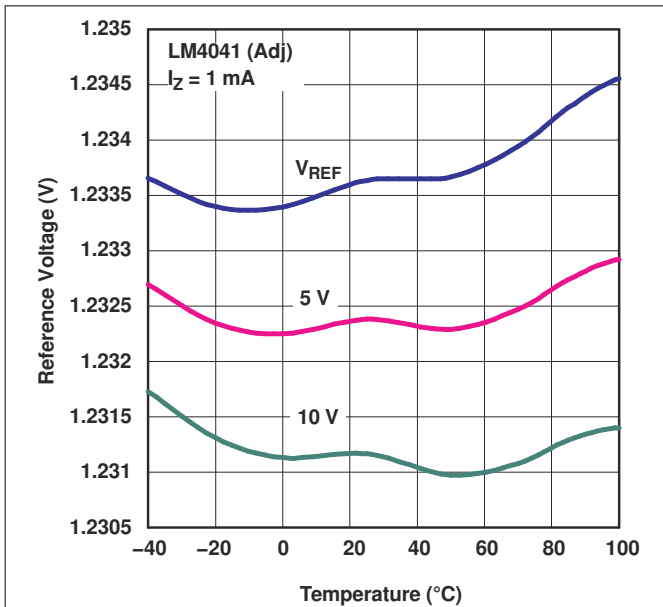

图 6-7. Output Impedance vs Frequency

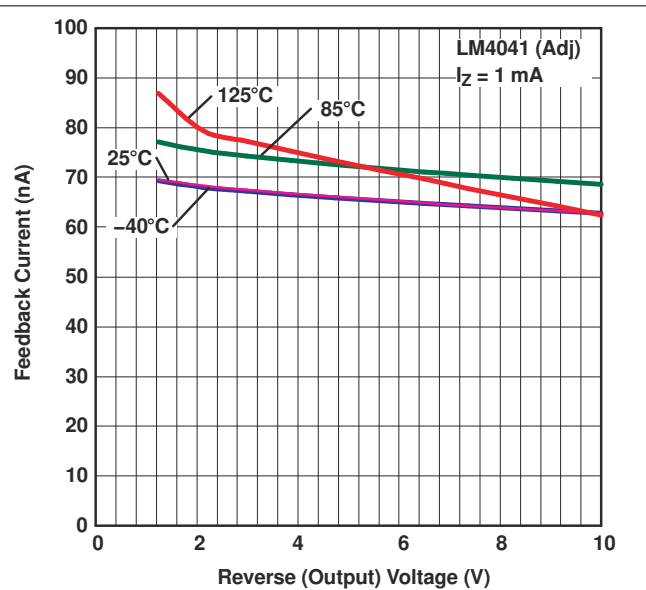

图 6-8. Output Impedance vs Frequency

6.9 Typical Characteristics (continued)

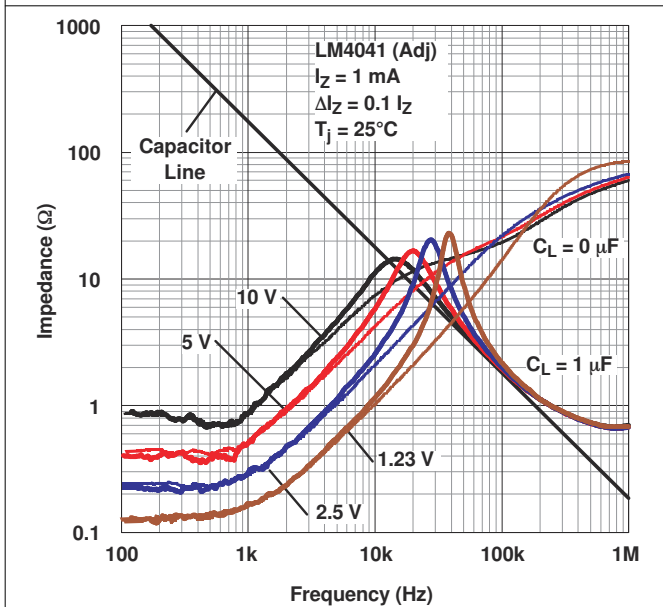

图 6-9. Reverse Characteristics

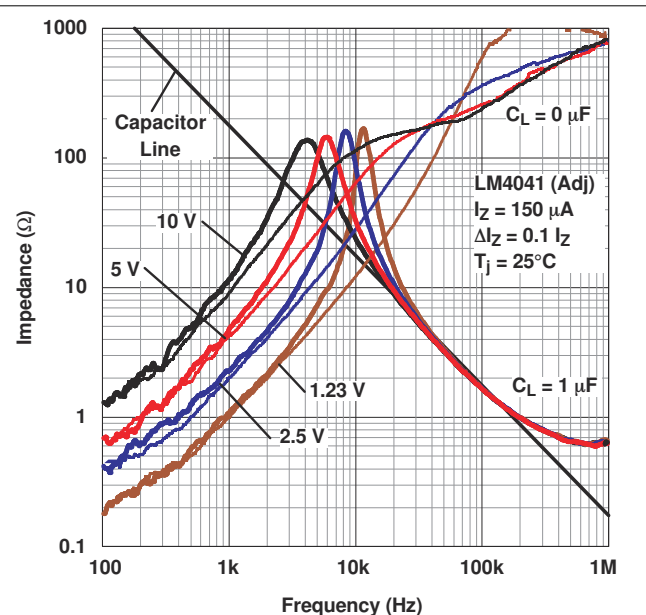
图 6-10. Reverse Characteristics and Minimum Operating Current

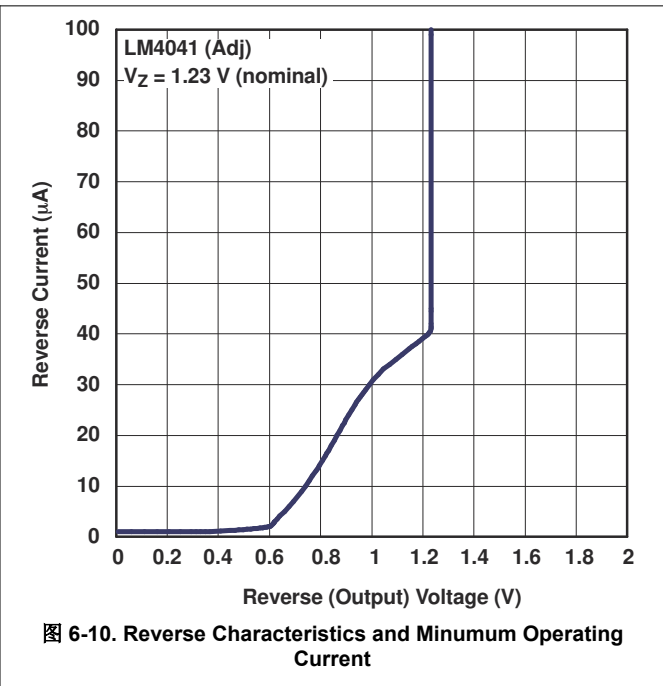
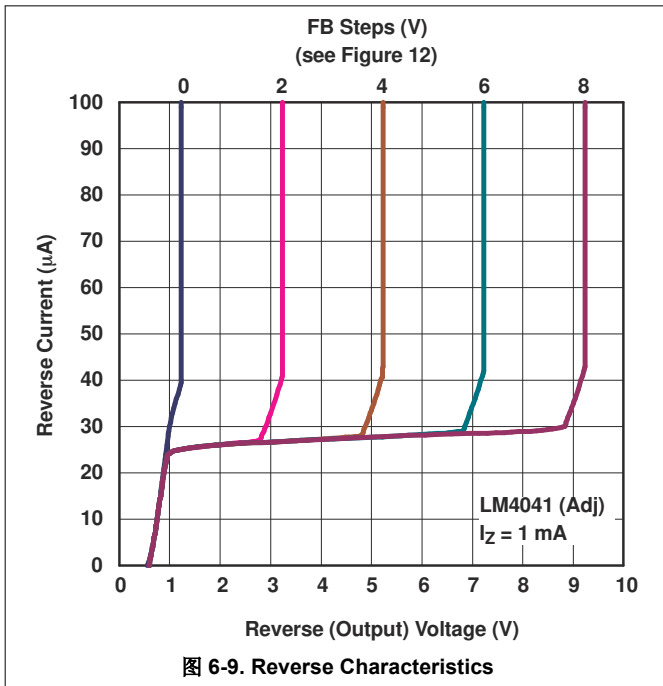

图 6-11. Output Saturation vs Output Current

7 Application Information



图 7-1. Startup Characteristics Test Circuit

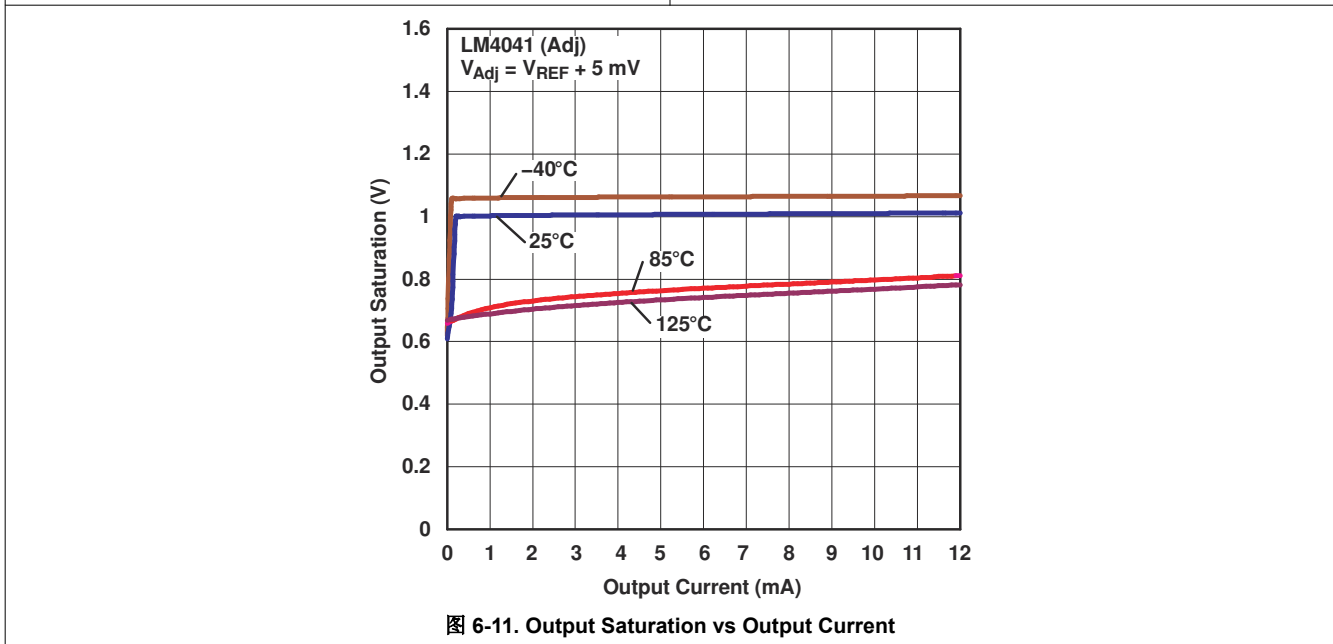

图 7-2. Reverse Characteristics Test Circuit

7.1 Output Capacitor

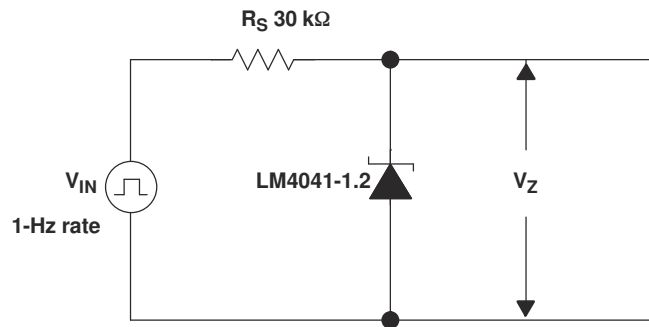
The LM4041 does not require an output capacitor across CATHODE and ANODE for stability. However, if an output bypass capacitor is desired, the LM4041 is designed to be stable with all capacitive loads.

7.2 SOT-23 and SC-70 Pin Connections

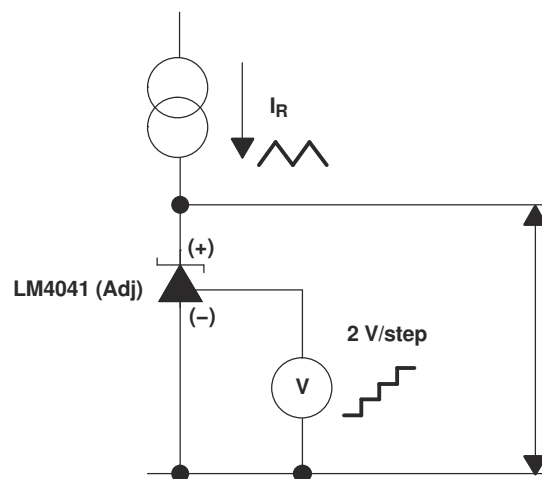
There is a parasitic Schottky diode connected between pins 2 and 3 of the SOT-23 packaged device. Thus, pin 3 of the SOT-23 package must be left floating or connected to pin 2. Similarly, pin 2 of the SC-70 package also must be left floating or connected to pin 1.

7.3 Adjustable Version

The adjustable version allows V_Z to be set by a user-defined resistor divider. The output voltage, V_Z , is set according to the equation shown in 图 7-3.



图 7-3. Adjustable Shunt Regulator

7.4 Cathode and Load Currents

In a typical shunt regulator configuration (see 图 7-4), an external resistor, R_S , is connected between the supply and the cathode of the LM4041. R_S must be set properly, this sets the total current available to supply the load (I_L) and bias the LM4041 (I_Z). In all cases, I_Z must stay within a specified range for proper operation of the reference. Taking into consideration one extreme in the variation of the load and supply voltage (maximum I_L and minimum V_S), R_S must be small enough to supply the minimum I_Z required for operation of the regulator, as given by data sheet parameters. At the other extreme, maximum V_S and minimum I_L , R_S must be large enough to limit I_Z to less than the maximum recommended rating of 12mA.

R_S is calculated as shown in 方程式 1.

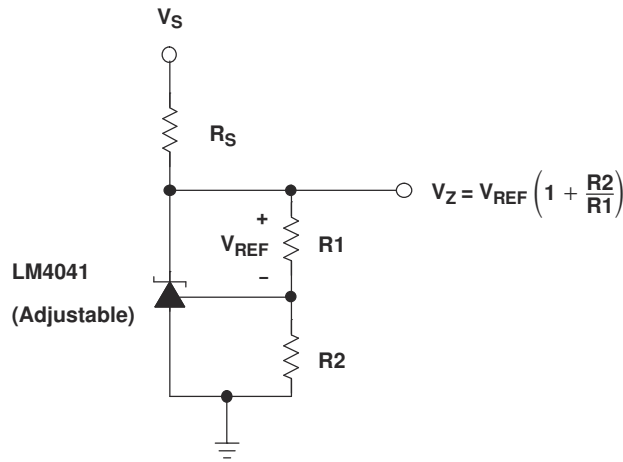
$$R_S = \frac{(V_S - V_Z)}{(I_L + I_Z)} \quad (1)$$



图 7-4. Shunt Regulator

8 器件和文档支持

8.1 接收文档更新通知

要接收文档更新通知，请导航至 ti.com 上的器件产品文件夹。点击 [通知](#) 进行注册，即可每周接收产品信息更改摘要。有关更改的详细信息，请查看任何已修订文档中包含的修订历史记录。

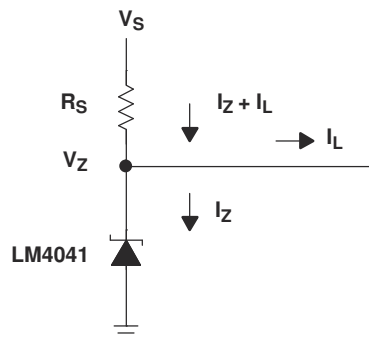
8.2 商标

TI E2E™ is a trademark of Texas Instruments.

所有商标均为其各自所有者的财产。

8.3 静电放电警告



静电放电 (ESD) 会损坏这个集成电路。德州仪器 (TI) 建议通过适当的预防措施处理所有集成电路。如果不遵守正确的处理和安装程序，可能会损坏集成电路。

ESD 的损坏小至导致微小的性能降级，大至整个器件故障。精密的集成电路可能更容易受到损坏，这是因为非常细微的参数更改都可能会导致器件与其发布的规格不相符。

8.4 支持资源

[TI E2E™ 中文支持论坛](#) 是工程师的重要参考资料，可直接从专家处获得快速、经过验证的解答和设计帮助。搜索现有解答或提出自己的问题，获得所需的快速设计帮助。

链接的内容由各个贡献者“按原样”提供。这些内容并不构成 TI 技术规范，并且不一定反映 TI 的观点；请参阅 TI 的 [使用条款](#)。

8.5 术语表

[TI 术语表](#) 本术语表列出并解释了术语、首字母缩略词和定义。

9 Revision History

注：以前版本的页码可能与当前版本的页码不同

Changes from Revision F (September 2020) to Revision G (July 2024)	Page
• 更新了 应用 链接.....	1
• Updated pinout diagrams	2

Changes from Revision E (February 2006) to Revision F (September 2020)**Page**

- 更新了整个文档中的表、图和交叉参考的编号格式..... 1
 - Deleted *Ordering Information* table. See Mechanical, Packaging, and Orderable Information at the end of the data sheet.....4
-

10 Mechanical, Packaging, and Orderable Information

The following pages include mechanical, packaging, and orderable information. This information is the most current data available for the designated devices. This data is subject to change without notice and revision of this document. For browser-based versions of this data sheet, refer to the left-hand navigation.

PACKAGING INFORMATION

Orderable Device	Status (1)	Package Type	Package Drawing	Pins	Package Qty	Eco Plan (2)	Lead finish/ Ball material (6)	MSL Peak Temp (3)	Op Temp (°C)	Device Marking (4/5)	Samples
LM4041A12IDBZR	ACTIVE	SOT-23	DBZ	3	3000	RoHS & Green	NIPDAU SN	Level-1-260C-UNLIM	-40 to 85	(4MK3, 4MKU)	Samples
LM4041A12IDBZT	ACTIVE	SOT-23	DBZ	3	250	RoHS & Green	NIPDAU	Level-1-260C-UNLIM	-40 to 85	(4MK3, 4MKU)	Samples
LM4041A12IDCKR	ACTIVE	SC70	DCK	5	3000	RoHS & Green	NIPDAU	Level-1-260C-UNLIM	-40 to 85	MKU	Samples
LM4041B12IDBZR	ACTIVE	SOT-23	DBZ	3	3000	RoHS & Green	NIPDAU	Level-1-260C-UNLIM	-40 to 85	(4ML3, 4MLU)	Samples
LM4041B12IDBZT	ACTIVE	SOT-23	DBZ	3	250	RoHS & Green	NIPDAU	Level-1-260C-UNLIM	-40 to 85	(4ML3, 4MLU)	Samples
LM4041B12IDCKR	ACTIVE	SC70	DCK	5	3000	RoHS & Green	NIPDAU	Level-1-260C-UNLIM	-40 to 85	MLU	Samples
LM4041BIDBZR	ACTIVE	SOT-23	DBZ	3	3000	RoHS & Green	NIPDAU	Level-1-260C-UNLIM	-40 to 85	(4MG3, 4MGU)	Samples
LM4041BIDBZR1G4	ACTIVE	SOT-23	DBZ	3	3000	RoHS & Green	NIPDAU	Level-1-260C-UNLIM		(4MG3, 4MGU)	Samples
LM4041BIDBZT	ACTIVE	SOT-23	DBZ	3	250	RoHS & Green	NIPDAU	Level-1-260C-UNLIM	-40 to 85	(4MG3, 4MGU)	Samples
LM4041BIDCKR	ACTIVE	SC70	DCK	5	3000	RoHS & Green	NIPDAU	Level-1-260C-UNLIM	-40 to 85	MGU	Samples
LM4041BIDCKT	ACTIVE	SC70	DCK	5	250	RoHS & Green	NIPDAU	Level-1-260C-UNLIM	-40 to 85	MGU	Samples
LM4041C12IDBZR	ACTIVE	SOT-23	DBZ	3	3000	RoHS & Green	NIPDAU	Level-1-260C-UNLIM	-40 to 85	(4MM3, 4MMU)	Samples
LM4041C12IDBZT	ACTIVE	SOT-23	DBZ	3	250	RoHS & Green	NIPDAU	Level-1-260C-UNLIM	-40 to 85	(4MM3, 4MMU)	Samples
LM4041C12IDCKR	ACTIVE	SC70	DCK	5	3000	RoHS & Green	NIPDAU	Level-1-260C-UNLIM	-40 to 85	MMU	Samples
LM4041C12IDCKRE4	ACTIVE	SC70	DCK	5	3000	TBD	Call TI	Call TI	-40 to 85		Samples
LM4041C12IDCKRG4	ACTIVE	SC70	DCK	5	3000	TBD	Call TI	Call TI	-40 to 85		Samples
LM4041C12ILP	ACTIVE	TO-92	LP	3	1000	RoHS & Green	SN	N / A for Pkg Type	-40 to 85	NPC12I	Samples
LM4041C12ILPR	ACTIVE	TO-92	LP	3	2000	RoHS & Green	SN	N / A for Pkg Type	-40 to 85	NPC12I	Samples
LM4041C12QDBZR	ACTIVE	SOT-23	DBZ	3	3000	RoHS & Green	NIPDAU	Level-1-260C-UNLIM	-40 to 125	(4MS3, 4MSU)	Samples
LM4041C12QDBZT	ACTIVE	SOT-23	DBZ	3	250	RoHS & Green	NIPDAU	Level-1-260C-UNLIM	-40 to 125	(4MS3, 4MSU)	Samples

Orderable Device	Status (1)	Package Type	Package Drawing	Pins	Package Qty	Eco Plan (2)	Lead finish/ Ball material (6)	MSL Peak Temp (3)	Op Temp (°C)	Device Marking (4/5)	Samples
LM4041CIDBZR	ACTIVE	SOT-23	DBZ	3	3000	RoHS & Green	NIPDAU	Level-1-260C-UNLIM	-40 to 85	(4MH3, 4MHU)	Samples
LM4041CIDBZT	ACTIVE	SOT-23	DBZ	3	250	RoHS & Green	NIPDAU	Level-1-260C-UNLIM	-40 to 85	(4MH3, 4MHU)	Samples
LM4041CIDCKR	ACTIVE	SC70	DCK	5	3000	RoHS & Green	NIPDAU	Level-1-260C-UNLIM	-40 to 85	MHU	Samples
LM4041CIDCKT	ACTIVE	SC70	DCK	5	250	RoHS & Green	NIPDAU	Level-1-260C-UNLIM	-40 to 85	MHU	Samples
LM4041CILP	OBSOLETE	TO-92	LP	3		TBD	Call TI	Call TI	-40 to 85	NPCI	
LM4041CILPE3	NRND	TO-92	LP	3	1000	TBD	Call TI	Call TI	-40 to 85		
LM4041CILPR	ACTIVE	TO-92	LP	3	2000	RoHS & Green	SN	N / A for Pkg Type	-40 to 85	NPCI	Samples
LM4041CQDBZR	ACTIVE	SOT-23	DBZ	3	3000	RoHS & Green	NIPDAU	Level-1-260C-UNLIM	-40 to 125	(4MP3, 4MPU)	Samples
LM4041CQDBZT	ACTIVE	SOT-23	DBZ	3	250	RoHS & Green	NIPDAU	Level-1-260C-UNLIM	-40 to 125	(4MP3, 4MPU)	Samples
LM4041D12IDBZR	ACTIVE	SOT-23	DBZ	3	3000	RoHS & Green	NIPDAU	Level-1-260C-UNLIM	-40 to 85	(4MN3, 4MNU)	Samples
LM4041D12IDBZT	ACTIVE	SOT-23	DBZ	3	250	RoHS & Green	NIPDAU	Level-1-260C-UNLIM	-40 to 85	(4MN3, 4MNU)	Samples
LM4041D12IDCKR	ACTIVE	SC70	DCK	5	3000	RoHS & Green	NIPDAU	Level-1-260C-UNLIM	-40 to 85	MNU	Samples
LM4041D12ILP	ACTIVE	TO-92	LP	3	1000	RoHS & Green	SN	N / A for Pkg Type	-40 to 85	NPD12I	Samples
LM4041D12ILPE3	ACTIVE	TO-92	LP	3	1000	TBD	Call TI	Call TI	-40 to 85		Samples
LM4041D12ILPR	ACTIVE	TO-92	LP	3	2000	RoHS & Green	SN	N / A for Pkg Type	-40 to 85	NPD12I	Samples
LM4041D12QDBZR	ACTIVE	SOT-23	DBZ	3	3000	RoHS & Green	NIPDAU	Level-1-260C-UNLIM	-40 to 125	(4MT3, 4MTU)	Samples
LM4041DIDBZR	ACTIVE	SOT-23	DBZ	3	3000	RoHS & Green	NIPDAU	Level-1-260C-UNLIM	-40 to 85	(4MJ3, 4MJU)	Samples
LM4041DIDBZT	ACTIVE	SOT-23	DBZ	3	250	RoHS & Green	NIPDAU	Level-1-260C-UNLIM	-40 to 85	(4MJ3, 4MJU)	Samples
LM4041DIDCKR	ACTIVE	SC70	DCK	5	3000	RoHS & Green	NIPDAU	Level-1-260C-UNLIM	-40 to 85	MJU	Samples
LM4041DIDCKRG4	ACTIVE	SC70	DCK	5	3000	RoHS & Green	NIPDAU	Level-1-260C-UNLIM	-40 to 85	MJU	Samples
LM4041DILP	OBSOLETE	TO-92	LP	3		TBD	Call TI	Call TI	-40 to 85	NPDI	
LM4041DILPR	ACTIVE	TO-92	LP	3	2000	RoHS & Green	SN	N / A for Pkg Type	-40 to 85	NPDI	Samples

Orderable Device	Status (1)	Package Type	Package Drawing	Pins	Package Qty	Eco Plan (2)	Lead finish/ Ball material (6)	MSL Peak Temp (3)	Op Temp (°C)	Device Marking (4/5)	Samples
LM4041DQDBZR	ACTIVE	SOT-23	DBZ	3	3000	RoHS & Green	NIPDAU	Level-1-260C-UNLIM	-40 to 125	(4MR3, 4MRU)	Samples
LM4041DQDBZT	ACTIVE	SOT-23	DBZ	3	250	RoHS & Green	NIPDAU	Level-1-260C-UNLIM	-40 to 125	(4MR3, 4MRU)	Samples

(1) The marketing status values are defined as follows:

ACTIVE: Product device recommended for new designs.

LIFEBUY: TI has announced that the device will be discontinued, and a lifetime-buy period is in effect.

NRND: Not recommended for new designs. Device is in production to support existing customers, but TI does not recommend using this part in a new design.

PREVIEW: Device has been announced but is not in production. Samples may or may not be available.

OBsolete: TI has discontinued the production of the device.

(2) **RoHS:** TI defines "RoHS" to mean semiconductor products that are compliant with the current EU RoHS requirements for all 10 RoHS substances, including the requirement that RoHS substance do not exceed 0.1% by weight in homogeneous materials. Where designed to be soldered at high temperatures, "RoHS" products are suitable for use in specified lead-free processes. TI may reference these types of products as "Pb-Free".

RoHS Exempt: TI defines "RoHS Exempt" to mean products that contain lead but are compliant with EU RoHS pursuant to a specific EU RoHS exemption.

Green: TI defines "Green" to mean the content of Chlorine (Cl) and Bromine (Br) based flame retardants meet JS709B low halogen requirements of <=1000ppm threshold. Antimony trioxide based flame retardants must also meet the <=1000ppm threshold requirement.

(3) **MSL, Peak Temp.** - The Moisture Sensitivity Level rating according to the JEDEC industry standard classifications, and peak solder temperature.

(4) There may be additional marking, which relates to the logo, the lot trace code information, or the environmental category on the device.

(5) Multiple Device Markings will be inside parentheses. Only one Device Marking contained in parentheses and separated by a "~" will appear on a device. If a line is indented then it is a continuation of the previous line and the two combined represent the entire Device Marking for that device.

(6) **Lead finish/Ball material** - Orderable Devices may have multiple material finish options. Finish options are separated by a vertical ruled line. Lead finish/Ball material values may wrap to two lines if the finish value exceeds the maximum column width.

Important Information and Disclaimer: The information provided on this page represents TI's knowledge and belief as of the date that it is provided. TI bases its knowledge and belief on information provided by third parties, and makes no representation or warranty as to the accuracy of such information. Efforts are underway to better integrate information from third parties. TI has taken and continues to take reasonable steps to provide representative and accurate information but may not have conducted destructive testing or chemical analysis on incoming materials and chemicals. TI and TI suppliers consider certain information to be proprietary, and thus CAS numbers and other limited information may not be available for release.

In no event shall TI's liability arising out of such information exceed the total purchase price of the TI part(s) at issue in this document sold by TI to Customer on an annual basis.

TAPE AND REEL INFORMATION

QUADRANT ASSIGNMENTS FOR PIN 1 ORIENTATION IN TAPE

*All dimensions are nominal

Device	Package Type	Package Drawing	Pins	SPQ	Reel Diameter (mm)	Reel Width W1 (mm)	A0 (mm)	B0 (mm)	K0 (mm)	P1 (mm)	W (mm)	Pin1 Quadrant
LM4041A12IDBZR	SOT-23	DBZ	3	3000	180.0	8.4	2.9	3.35	1.35	4.0	8.0	Q3
LM4041A12IDBZT	SOT-23	DBZ	3	250	180.0	8.4	2.9	3.35	1.35	4.0	8.0	Q3
LM4041A12IDCKR	SC70	DCK	5	3000	179.0	8.4	2.2	2.5	1.2	4.0	8.0	Q3
LM4041B12IDBZR	SOT-23	DBZ	3	3000	180.0	8.4	2.9	3.35	1.35	4.0	8.0	Q3
LM4041B12IDBZT	SOT-23	DBZ	3	250	180.0	8.4	2.9	3.35	1.35	4.0	8.0	Q3
LM4041B12IDCKR	SC70	DCK	5	3000	179.0	8.4	2.2	2.5	1.2	4.0	8.0	Q3
LM4041BIDBZR	SOT-23	DBZ	3	3000	179.0	8.4	3.15	2.95	1.22	4.0	8.0	Q3
LM4041BIDBZT	SOT-23	DBZ	3	3000	178.0	9.2	3.15	2.77	1.22	4.0	8.0	Q3
LM4041BIDBZR1G4	SOT-23	DBZ	3	3000	179.0	8.4	3.15	2.95	1.22	4.0	8.0	Q3
LM4041BIDBZR1G4	SOT-23	DBZ	3	3000	178.0	9.2	3.15	2.77	1.22	4.0	8.0	Q3
LM4041BIDBZT	SOT-23	DBZ	3	250	179.0	8.4	3.15	2.95	1.22	4.0	8.0	Q3
LM4041BIDBZT	SOT-23	DBZ	3	250	178.0	9.2	3.15	2.77	1.22	4.0	8.0	Q3
LM4041BIDCKR	SC70	DCK	5	3000	179.0	8.4	2.2	2.5	1.2	4.0	8.0	Q3
LM4041BIDCKT	SC70	DCK	5	250	179.0	8.4	2.2	2.5	1.2	4.0	8.0	Q3
LM4041C12IDBZR	SOT-23	DBZ	3	3000	180.0	8.4	2.9	3.35	1.35	4.0	8.0	Q3
LM4041C12IDBZT	SOT-23	DBZ	3	250	180.0	8.4	2.9	3.35	1.35	4.0	8.0	Q3

Device	Package Type	Package Drawing	Pins	SPQ	Reel Diameter (mm)	Reel Width W1 (mm)	A0 (mm)	B0 (mm)	K0 (mm)	P1 (mm)	W (mm)	Pin1 Quadrant
LM4041C12IDCKR	SC70	DCK	5	3000	179.0	8.4	2.2	2.5	1.2	4.0	8.0	Q3
LM4041C12QDBZR	SOT-23	DBZ	3	3000	180.0	8.4	2.9	3.35	1.35	4.0	8.0	Q3
LM4041C12QDBZT	SOT-23	DBZ	3	250	180.0	8.4	2.9	3.35	1.35	4.0	8.0	Q3
LM4041CIDBZR	SOT-23	DBZ	3	3000	179.0	8.4	3.15	2.95	1.22	4.0	8.0	Q3
LM4041CIDBZR	SOT-23	DBZ	3	3000	178.0	9.2	3.15	2.77	1.22	4.0	8.0	Q3
LM4041CIDBZT	SOT-23	DBZ	3	250	178.0	9.2	3.15	2.77	1.22	4.0	8.0	Q3
LM4041CIDBZT	SOT-23	DBZ	3	250	179.0	8.4	3.15	2.95	1.22	4.0	8.0	Q3
LM4041CIDCKR	SC70	DCK	5	3000	179.0	8.4	2.2	2.5	1.2	4.0	8.0	Q3
LM4041CIDCKT	SC70	DCK	5	250	179.0	8.4	2.2	2.5	1.2	4.0	8.0	Q3
LM4041CQDBZR	SOT-23	DBZ	3	3000	178.0	9.2	3.15	2.77	1.22	4.0	8.0	Q3
LM4041CQDBZR	SOT-23	DBZ	3	3000	179.0	8.4	3.15	2.95	1.22	4.0	8.0	Q3
LM4041CQDBZT	SOT-23	DBZ	3	250	178.0	9.2	3.15	2.77	1.22	4.0	8.0	Q3
LM4041CQDBZT	SOT-23	DBZ	3	250	179.0	8.4	3.15	2.95	1.22	4.0	8.0	Q3
LM4041D12IDBZR	SOT-23	DBZ	3	3000	180.0	8.4	2.9	3.35	1.35	4.0	8.0	Q3
LM4041D12IDBZT	SOT-23	DBZ	3	250	180.0	8.4	2.9	3.35	1.35	4.0	8.0	Q3
LM4041D12IDCKR	SC70	DCK	5	3000	179.0	8.4	2.2	2.5	1.2	4.0	8.0	Q3
LM4041D12QDBZR	SOT-23	DBZ	3	3000	180.0	8.4	2.9	3.35	1.35	4.0	8.0	Q3
LM4041DIDBZR	SOT-23	DBZ	3	3000	178.0	9.2	3.15	2.77	1.22	4.0	8.0	Q3
LM4041DIDBZR	SOT-23	DBZ	3	3000	179.0	8.4	3.15	2.95	1.22	4.0	8.0	Q3
LM4041DIDBZT	SOT-23	DBZ	3	250	178.0	9.2	3.15	2.77	1.22	4.0	8.0	Q3
LM4041DIDCKR	SC70	DCK	5	3000	179.0	8.4	2.2	2.5	1.2	4.0	8.0	Q3
LM4041DIDCKRG4	SC70	DCK	5	3000	179.0	8.4	2.2	2.5	1.2	4.0	8.0	Q3
LM4041DQDBZR	SOT-23	DBZ	3	3000	178.0	9.2	3.15	2.77	1.22	4.0	8.0	Q3
LM4041DQDBZR	SOT-23	DBZ	3	3000	179.0	8.4	3.15	2.95	1.22	4.0	8.0	Q3
LM4041DQDBZT	SOT-23	DBZ	3	250	178.0	9.2	3.15	2.77	1.22	4.0	8.0	Q3
LM4041DQDBZT	SOT-23	DBZ	3	250	179.0	8.4	3.15	2.95	1.22	4.0	8.0	Q3

TAPE AND REEL BOX DIMENSIONS

*All dimensions are nominal

Device	Package Type	Package Drawing	Pins	SPQ	Length (mm)	Width (mm)	Height (mm)
LM4041A12IDBZR	SOT-23	DBZ	3	3000	210.0	185.0	35.0
LM4041A12IDBZT	SOT-23	DBZ	3	250	210.0	185.0	35.0
LM4041A12IDCKR	SC70	DCK	5	3000	200.0	183.0	25.0
LM4041B12IDBZR	SOT-23	DBZ	3	3000	210.0	185.0	35.0
LM4041B12IDBZT	SOT-23	DBZ	3	250	210.0	185.0	35.0
LM4041B12IDCKR	SC70	DCK	5	3000	200.0	183.0	25.0
LM4041BIDBZR	SOT-23	DBZ	3	3000	200.0	183.0	25.0
LM4041BIDBZT	SOT-23	DBZ	3	3000	180.0	180.0	18.0
LM4041BIDBZR1G4	SOT-23	DBZ	3	3000	200.0	183.0	25.0
LM4041BIDBZR1G4	SOT-23	DBZ	3	3000	180.0	180.0	18.0
LM4041BIDBZT	SOT-23	DBZ	3	250	200.0	183.0	25.0
LM4041BIDBZT	SOT-23	DBZ	3	250	180.0	180.0	18.0
LM4041BIDCKR	SC70	DCK	5	3000	200.0	183.0	25.0
LM4041BIDCKT	SC70	DCK	5	250	203.0	203.0	35.0
LM4041C12IDBZR	SOT-23	DBZ	3	3000	210.0	185.0	35.0
LM4041C12IDBZT	SOT-23	DBZ	3	250	210.0	185.0	35.0
LM4041C12IDCKR	SC70	DCK	5	3000	200.0	183.0	25.0
LM4041C12QDBZR	SOT-23	DBZ	3	3000	210.0	185.0	35.0

Device	Package Type	Package Drawing	Pins	SPQ	Length (mm)	Width (mm)	Height (mm)
LM4041C12QDBZT	SOT-23	DBZ	3	250	210.0	185.0	35.0
LM4041CIDBZR	SOT-23	DBZ	3	3000	200.0	183.0	25.0
LM4041CIDBZR	SOT-23	DBZ	3	3000	180.0	180.0	18.0
LM4041CIDBZT	SOT-23	DBZ	3	250	180.0	180.0	18.0
LM4041CIDBZT	SOT-23	DBZ	3	250	203.0	203.0	35.0
LM4041CIDCKR	SC70	DCK	5	3000	200.0	183.0	25.0
LM4041CIDCKT	SC70	DCK	5	250	200.0	183.0	25.0
LM4041CQDBZR	SOT-23	DBZ	3	3000	180.0	180.0	18.0
LM4041CQDBZR	SOT-23	DBZ	3	3000	200.0	183.0	25.0
LM4041CQDBZT	SOT-23	DBZ	3	250	180.0	180.0	18.0
LM4041CQDBZT	SOT-23	DBZ	3	250	200.0	183.0	25.0
LM4041D12IDBZR	SOT-23	DBZ	3	3000	210.0	185.0	35.0
LM4041D12IDBZT	SOT-23	DBZ	3	250	210.0	185.0	35.0
LM4041D12IDCKR	SC70	DCK	5	3000	200.0	183.0	25.0
LM4041D12QDBZR	SOT-23	DBZ	3	3000	210.0	185.0	35.0
LM4041DIDBZR	SOT-23	DBZ	3	3000	180.0	180.0	18.0
LM4041DIDBZR	SOT-23	DBZ	3	3000	200.0	183.0	25.0
LM4041DIDBZT	SOT-23	DBZ	3	250	180.0	180.0	18.0
LM4041DIDCKR	SC70	DCK	5	3000	200.0	183.0	25.0
LM4041DIDCKRG4	SC70	DCK	5	3000	200.0	183.0	25.0
LM4041DQDBZR	SOT-23	DBZ	3	3000	180.0	180.0	18.0
LM4041DQDBZR	SOT-23	DBZ	3	3000	200.0	183.0	25.0
LM4041DQDBZT	SOT-23	DBZ	3	250	180.0	180.0	18.0
LM4041DQDBZT	SOT-23	DBZ	3	250	203.0	203.0	35.0

DBZ0003A

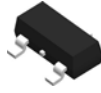

PACKAGE OUTLINE

SOT-23 - 1.12 mm max height

SMALL OUTLINE TRANSISTOR

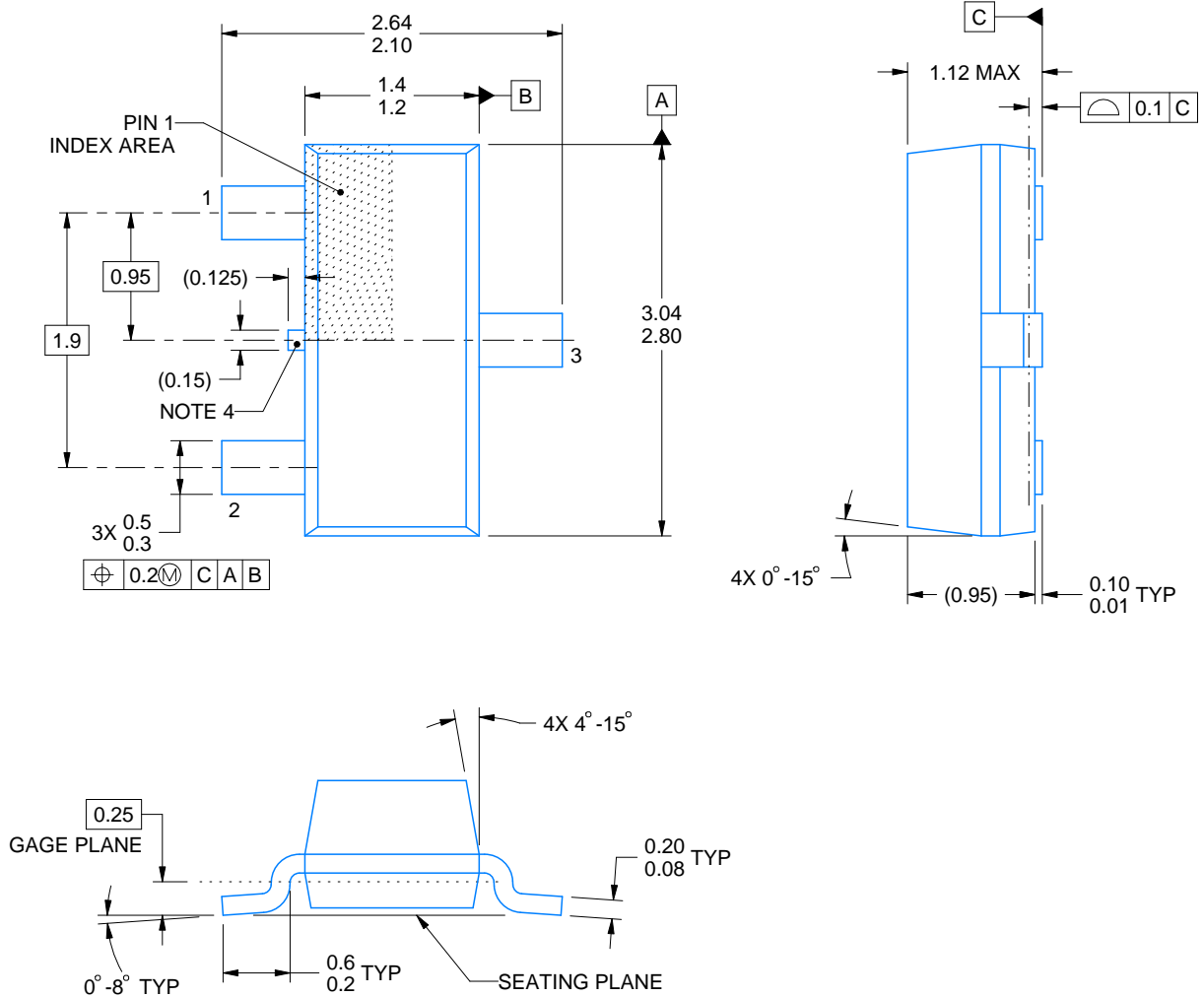

4214838/F 08/2024

NOTES:

1. All linear dimensions are in millimeters. Any dimensions in parenthesis are for reference only. Dimensioning and tolerancing per ASME Y14.5M.
2. This drawing is subject to change without notice.
3. Reference JEDEC registration TO-236, except minimum foot length.
4. Support pin may differ or may not be present.
5. Body dimensions do not include mold flash, protrusions, or gate burrs. Mold flash, protrusions, or gate burrs shall not exceed 0.25mm per side

EXAMPLE BOARD LAYOUT

DBZ0003A

SOT-23 - 1.12 mm max height

SMALL OUTLINE TRANSISTOR



LAND PATTERN EXAMPLE
SCALE:15X



SOLDER MASK DETAILS

4214838/F 08/2024

NOTES: (continued)

- 5. Publication IPC-7351 may have alternate designs.
- 6. Solder mask tolerances between and around signal pads can vary based on board fabrication site.

EXAMPLE STENCIL DESIGN

DBZ0003A

SOT-23 - 1.12 mm max height

SMALL OUTLINE TRANSISTOR



SOLDER PASTE EXAMPLE
BASED ON 0.125 THICK STENCIL
SCALE:15X

4214838/F 08/2024

NOTES: (continued)

7. Laser cutting apertures with trapezoidal walls and rounded corners may offer better paste release. IPC-7525 may have alternate design recommendations.
8. Board assembly site may have different recommendations for stencil design.



PACKAGE OUTLINE

DCK0005A

SOT - 1.1 max height

SMALL OUTLINE TRANSISTOR



4214834/G 11/2024

NOTES:

1. All linear dimensions are in millimeters. Any dimensions in parenthesis are for reference only. Dimensioning and tolerancing per ASME Y14.5M.
2. This drawing is subject to change without notice.
3. Reference JEDEC MO-203.
4. Support pin may differ or may not be present.
5. Lead width does not comply with JEDEC.
6. Body dimensions do not include mold flash, protrusions, or gate burrs. Mold flash, protrusions, or gate burrs shall not exceed 0.25mm per side

EXAMPLE BOARD LAYOUT

DCK0005A

SOT - 1.1 max height

SMALL OUTLINE TRANSISTOR



LAND PATTERN EXAMPLE
EXPOSED METAL SHOWN
SCALE:18X



SOLDER MASK DETAILS

4214834/G 11/2024

NOTES: (continued)

- 7. Publication IPC-7351 may have alternate designs.
- 8. Solder mask tolerances between and around signal pads can vary based on board fabrication site.

EXAMPLE STENCIL DESIGN

DCK0005A

SOT - 1.1 max height

SMALL OUTLINE TRANSISTOR



SOLDER PASTE EXAMPLE
BASED ON 0.125 THICK STENCIL
SCALE: 18X

4214834/G 11/2024

NOTES: (continued)

9. Laser cutting apertures with trapezoidal walls and rounded corners may offer better paste release. IPC-7525 may have alternate design recommendations.
10. Board assembly site may have different recommendations for stencil design.

GENERIC PACKAGE VIEW

LP 3

TO-92 - 5.34 mm max height

TRANSISTOR OUTLINE



Images above are just a representation of the package family, actual package may vary.
Refer to the product data sheet for package details.

4040001-2/F

LP0003A



PACKAGE OUTLINE

TO-92 - 5.34 mm max height

TO-92



4215214/B 04/2017

NOTES:

1. All linear dimensions are in millimeters. Any dimensions in parenthesis are for reference only. Dimensioning and tolerancing per ASME Y14.5M.
2. This drawing is subject to change without notice.
3. Lead dimensions are not controlled within this area.
4. Reference JEDEC TO-226, variation AA.
5. Shipping method:
 - a. Straight lead option available in bulk pack only.
 - b. Formed lead option available in tape and reel or ammo pack.
 - c. Specific products can be offered in limited combinations of shipping medium and lead options.
 - d. Consult product folder for more information on available options.

EXAMPLE BOARD LAYOUT

LP0003A

TO-92 - 5.34 mm max height

TO-92

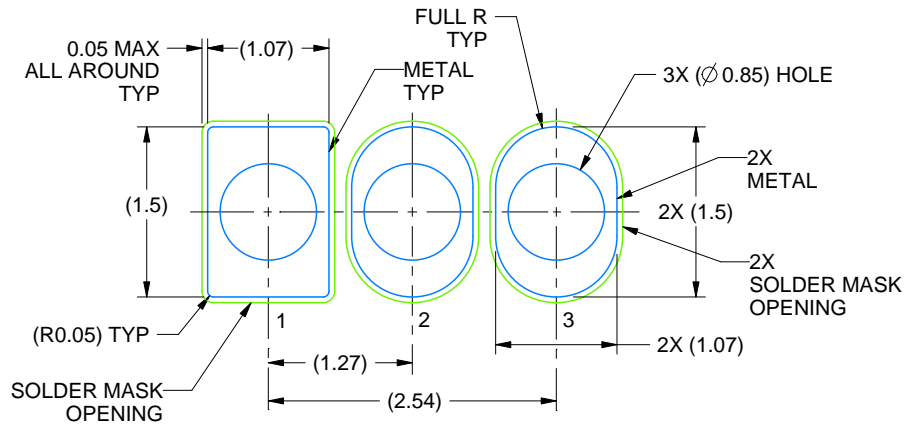

LAND PATTERN EXAMPLE
STRAIGHT LEAD OPTION
NON-SOLDER MASK DEFINED
SCALE:15X



LAND PATTERN EXAMPLE
FORMED LEAD OPTION
NON-SOLDER MASK DEFINED
SCALE:15X

4215214/B 04/2017

TAPE SPECIFICATIONS

LP0003A

TO-92 - 5.34 mm max height

TO-92

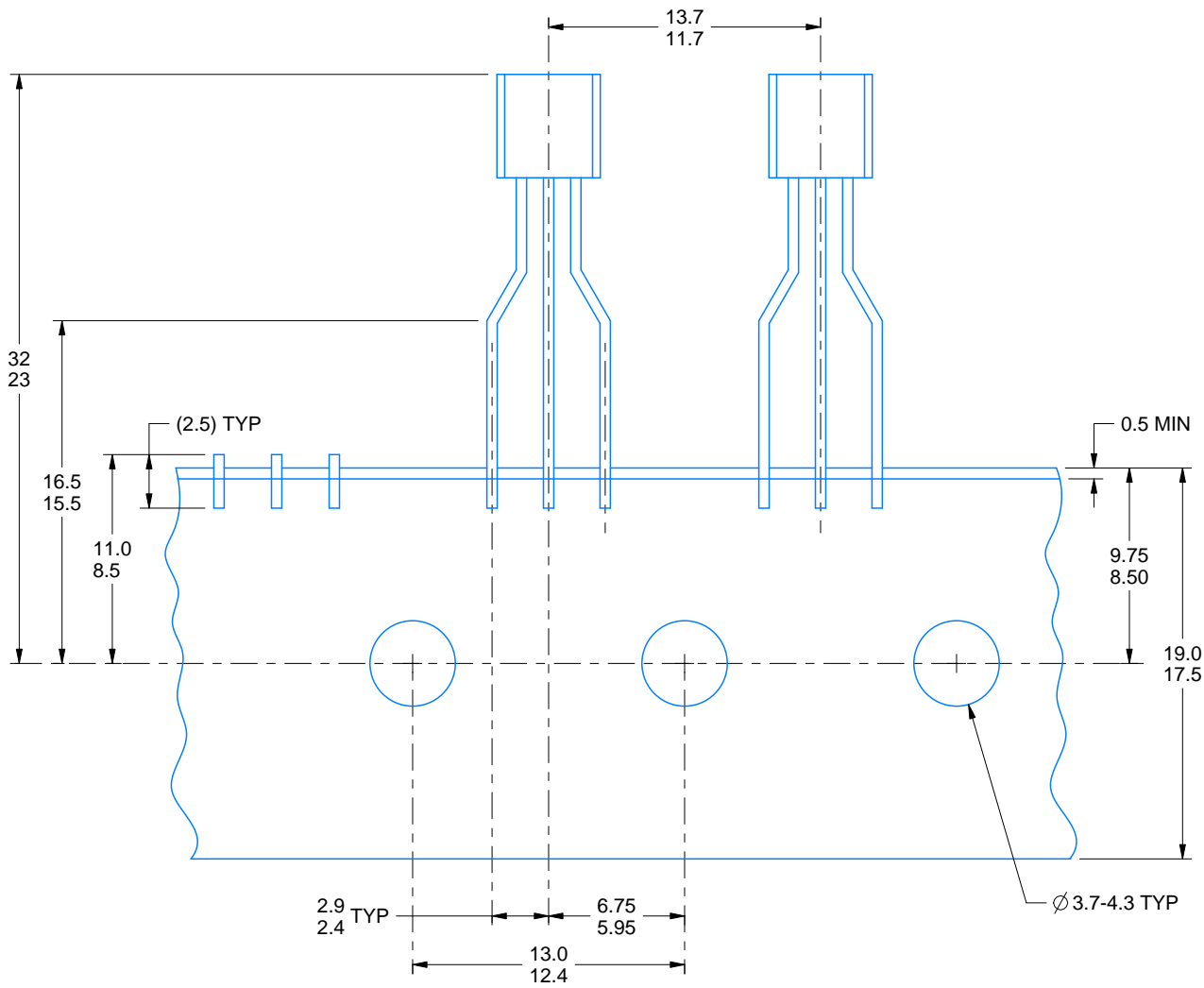

FOR FORMED LEAD OPTION PACKAGE

4215214/B 04/2017

重要通知和免责声明

TI“按原样”提供技术和可靠性数据（包括数据表）、设计资源（包括参考设计）、应用或其他设计建议、网络工具、安全信息和其他资源，不保证没有瑕疵且不做任何明示或暗示的担保，包括但不限于对适销性、某特定用途方面的适用性或不侵犯任何第三方知识产权的暗示担保。

这些资源可供使用 TI 产品进行设计的熟练开发人员使用。您将自行承担以下全部责任：(1) 针对您的应用选择合适的 TI 产品，(2) 设计、验证并测试您的应用，(3) 确保您的应用满足相应标准以及任何其他功能安全、信息安全、监管或其他要求。

这些资源如有变更，恕不另行通知。TI 授权您仅可将这些资源用于研发本资源所述的 TI 产品的相关应用。严禁以其他方式对这些资源进行复制或展示。您无权使用任何其他 TI 知识产权或任何第三方知识产权。您应全额赔偿因在这些资源的使用中对 TI 及其代表造成的任何索赔、损害、成本、损失和债务，TI 对此概不负责。

TI 提供的产品受 [TI 的销售条款](#) 或 [ti.com](#) 上其他适用条款/TI 产品随附的其他适用条款的约束。TI 提供这些资源并不会扩展或以其他方式更改 TI 针对 TI 产品发布的适用的担保或担保免责声明。

TI 反对并拒绝您可能提出的任何其他或不同的条款。

邮寄地址：Texas Instruments, Post Office Box 655303, Dallas, Texas 75265
版权所有 © 2025，德州仪器 (TI) 公司