

## OPA177 0.1 $\mu$ V/ $^{\circ}$ C 温漂、10 $\mu$ V 失调电压、低噪声、双极运算放大器

### 1 特性

- 低失调电压：25 $\mu$ V (最大值)
- 低失调电压漂移：0.3 $\mu$ V/ $^{\circ}$ C (最大值)
- 高开环增益：134dB (最小值)
- 低静态电流：1.3mA (典型值)
- 低输入偏置电流： $\pm$ 2nA (最大值)
- 宽电源电压范围：6V 至 36V
- 取代了业界通用运算放大器：OP-07、OP-77、OP-177、AD707 等
- 如需通过  $\pm$ 40V 过压保护来提高性能，请参阅 [OPA206](#)

### 2 应用

- 模拟输入模块
- 数据采集 (DAQ)
- 电池测试
- 实验室和现场仪表
- 温度变送器

### 3 说明

OPA177 精密双极运算放大器具有超低的失调电压和温漂。激光修整失调电压、温漂和输入偏置电流基本上消除了成本高昂的外部修整。得益于高性能和低成本，此类器件成为各种精密仪表的理想选择。

OPA177 的低静态电流显著降低了由于输入互连中的热电效应而导致的预热温漂和误差。OPA177 为斩波稳定型放大器提供了有效的替代方案。OPA177 的低噪声有助于尽可能保持信号完整性。

OPA177 提供多种性能级别的输出。封装选项包括 8 引脚塑料 DIP 和 SO-8 表面贴装型封装。

#### 封装信息

器件型号	封装 <sup>(1)</sup>	封装尺寸 <sup>(2)</sup>
OPA177	D (SOIC, 8)	4.9mm $\times$ 6mm
	P (PDIP, 8)	9.81mm $\times$ 9.43mm

- (1) 如需了解所有可用封装，请参阅数据表末尾的可订购产品附录。
- (2) 封装尺寸 (长  $\times$  宽) 为标称值，并包括引脚 (如适用)。

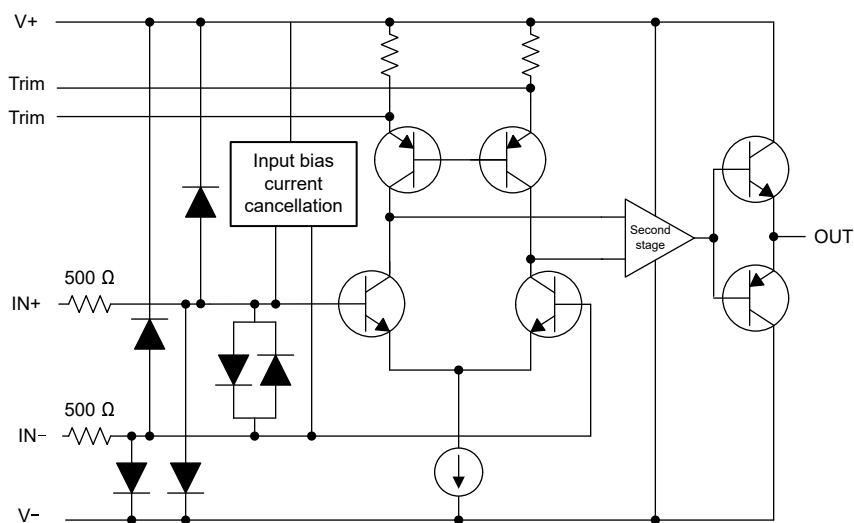

## Table of Contents

<b>1 特性</b> .....	1	<b>7 Application and Implementation</b> .....	10
<b>2 应用</b> .....	1	7.1 Application Information.....	10
<b>3 说明</b> .....	1	7.2 Typical Application.....	11
<b>4 Revision History</b> .....	2	<b>8 Device and Documentation Support</b> .....	12
<b>5 Pin Configuration and Functions</b> .....	3	8.1 器件支持.....	12
<b>6 Specifications</b> .....	4	8.2 接收文档更新通知.....	12
6.1 Absolute Maximum Ratings.....	4	8.3 支持资源.....	12
6.2 ESD Ratings.....	4	8.4 Trademarks.....	13
6.3 Recommended Operating Conditions.....	4	8.5 静电放电警告.....	13
6.4 Thermal Information.....	4	8.6 术语表.....	13
6.5 Electrical Characteristics.....	5	<b>9 Mechanical, Packaging, and Orderable Information</b> ..	13
6.6 Typical Characteristics.....	7		

## 4 Revision History

注：以前版本的页码可能与当前版本的页码不同

Changes from Revision * (September 2000) to Revision A (September 2023)	Page
• 更新了整个文档中的表格、图和交叉参考的编号格式.....	1
• 为了清晰起见，更改了数据表标题.....	1
• 添加了封装信息表、典型应用、器件和文档支持以及机械、封装和可订购信息部分.....	1
• 添加了额外的特性要点并更新了若干项规格，以便与电气特性保持一致.....	1
• 更改了应用列表项以显示链接的应用.....	1
• 为了清晰起见，更改了说明.....	1
• 更新了首页图.....	1
• Added pin functions table.....	3
• Changed supply voltage from $\pm 22\text{ V}$ (44 V) to 40 V in <i>Absolute Maximum Ratings</i> .....	4
• Moved operating temperature from <i>Absolute Maximum Ratings</i> to <i>Recommended Operating Conditions</i> .....	4
• Deleted lead temperature from <i>Absolute Maximum Ratings</i> .....	4
• Moved junction to ambient thermal information from <i>Absolute Maximum Ratings</i> to <i>Thermal Information</i> .....	4
• Added <i>ESD Ratings</i> and <i>Thermal Information</i> .....	4
• Changed several parameter names for consistency with modern data sheets in <i>Electrical Characteristics</i> .....	5
• Updated the format of <i>Electrical Characteristics</i> .....	5
• Added test conditions to the header of <i>Electrical Characteristics</i> .....	5
• Moved test conditions from condition column to the header of <i>Electrical Characteristics</i> .....	5
• Changed open-loop voltage gain unit from V/mV to dB in <i>Electrical Characteristics</i> .....	5
• Changed large signal voltage gain to open-loop voltage gain in <i>Electrical Characteristics</i> .....	5
• Changed Power Supply parameters no load test condition to $I_O = 0\text{ A}$ in <i>Electrical Characteristics</i> .....	5
• Updated quiescent current maximum over temperature specification value from 25 mA (typo) to $\pm 2.5\text{ mA}$ .....	5
• Changed supply current to quiescent current in <i>Electrical Characteristics</i> .....	5
• Added information about integrated overvoltage protection including OPAx206 to Input Protection.....	10
• Updated Noise Performance with new products such as the OPAx828, OPAx140, and OPAx210.....	10
• Changed operational amplifier recommendations to reflect new product developments.....	10

## 5 Pin Configuration and Functions

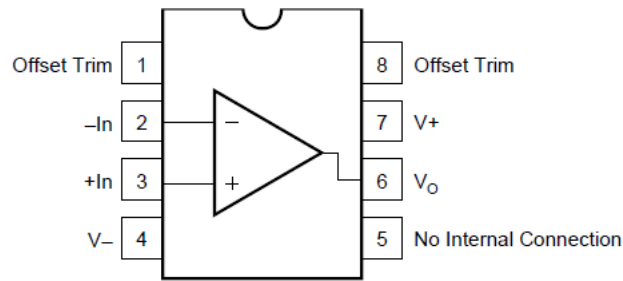

**图 5-1. D Package, 8-Pin SOIC  
and P Package, 8-Pin PDIP  
(Top View)**

**表 5-1. Pin Functions**

PIN		TYPE	DESCRIPTION
NAME	NO.		
+In	3	Input	Noninverting input
-In	2	Input	Inverting input
No Internal Connection	5	—	No internal connection (can be left floating)
Offset Trim	1, 8	—	Input offset voltage trim (leave floating if not used)
V+	7	Power	Positive (highest) power supply
V-	4	Power	Negative (lowest) power supply
V <sub>O</sub>	6	Output	Output

## 6 Specifications

### 6.1 Absolute Maximum Ratings

over operating free-air temperature range (unless otherwise noted)<sup>(1)</sup>

		MIN	MAX	UNIT
V <sub>S</sub>	Supply voltage, V <sub>S</sub> = (V+) – (V–)		40	V
	Input voltage	(V–)	(V+)	V
	Differential input voltage	–30	30	V
I <sub>SC</sub>	Output short circuit <sup>(2)</sup>	Continuous		
T <sub>J</sub>	Junction temperature		150	°C
T <sub>STG</sub>	Storage temperature	–65	125	°C

- (1) Stresses beyond those listed under *Absolute Maximum Ratings* may cause permanent damage to the device. These are stress ratings only, which do not imply functional operation of the device at these or any other conditions beyond those indicated under *Recommended Operating Conditions*. Exposure to absolute-maximum-rated conditions for extended periods may affect device reliability.
- (2) Short-circuit to ground, one amplifier per package.

### 6.2 ESD Ratings

			VALUE	UNIT
V <sub>(ESD)</sub>	Electrostatic discharge	Human-body model (HBM), per ANSI/ESDA/JEDEC JS-001 <sup>(1)</sup>	±1000	V

- (1) JEDEC document JEP155 states that 500-V HBM allows safe manufacturing with a standard ESD control process.

### 6.3 Recommended Operating Conditions

over operating free-air temperature range (unless otherwise noted)

			MIN	NOM	MAX	UNIT
V <sub>S</sub>	Supply voltage, V <sub>S</sub> = (V+) – (V–)	Single supply	6	30	36	V
		Dual supply	±3	±15	±18	
T <sub>A</sub>	Ambient temperature		–40		85	°C

### 6.4 Thermal Information

THERMAL METRIC <sup>(1)</sup>		OPA177		UNIT
		D (SOIC)	P (PDIP)	
		8 PINS	8 PINS	
R <sub>θJA</sub>	Junction-to-ambient thermal resistance	160.0	100.0	°C/W

- (1) For more information about traditional and new thermal metrics, see the [Semiconductor and IC Package Thermal Metrics](#) application report

## 6.5 Electrical Characteristics

at  $T_A = 25^\circ\text{C}$ ,  $V_S = 30\text{ V}$  ( $\pm 15\text{ V}$ ),  $V_{CM} = V_{OUT} = V_S / 2$ , and  $R_L = 2\text{ k}\Omega$  connected to  $V_S / 2$  (unless otherwise noted)

PARAMETER		TEST CONDITIONS		MIN	TYP	MAX	UNIT	
<b>OFFSET VOLTAGE</b>								
VOS	Input offset voltage	F grade			$\pm 10$	$\pm 25$	$\mu\text{V}$	
		G grade			$\pm 20$	$\pm 60$		
		$T_A = -40^\circ\text{C}$ to $+85^\circ\text{C}$	F grade			$\pm 15$		$\pm 40$
			G grade			$\pm 20$		$\pm 100$
dV <sub>OS</sub> /dT	Input offset voltage drift	$T_A = -40^\circ\text{C}$ to $+85^\circ\text{C}$		F grade		$\pm 0.1$	$\pm 0.3$	$\mu\text{V}/^\circ\text{C}$
				G grade		$\pm 0.7$	$\pm 1.2$	
	Offset adjustment range	$R_P = 20\text{ k}\Omega$			$\pm 3$		mV	
	Long-term drift <sup>(1)</sup>	F grade			0.3		$\mu\text{V}/\text{mo}$	
		G grade			0.4			
PSRR	Power-supply rejection ratio	$V_S = \pm 3\text{ V}$ to $\pm 18\text{ V}$		F grade		115	125	dB
				G grade		110	120	
		$V_S = \pm 3\text{ V}$ to $\pm 18\text{ V}$ $T_A = -40^\circ\text{C}$ to $+85^\circ\text{C}$		F grade		110	120	
				G grade		106	115	
<b>INPUT BIAS CURRENT</b>								
I <sub>B</sub>	Input bias current	F grade			$\pm 0.5$	$\pm 2$	nA	
		G grade			$\pm 0.5$	$\pm 2.8$		
		$T_A = -40^\circ\text{C}$ to $+85^\circ\text{C}$	F grade			$\pm 0.5$		$\pm 4$
			G grade			$\pm 0.5$		$\pm 6$
	Input bias current drift <sup>(2)</sup>	$T_A = -40^\circ\text{C}$ to $+85^\circ\text{C}$		F grade		$\pm 8$	$\pm 40$	$\text{pA}/^\circ\text{C}$
				G grade		$\pm 15$	$\pm 60$	
I <sub>OS</sub>	Input offset current	F grade			$\pm 0.3$	$\pm 1.5$	nA	
		G grade			$\pm 0.3$	$\pm 2.8$		
		$T_A = -40^\circ\text{C}$ to $+85^\circ\text{C}$	F grade			$\pm 0.5$		$\pm 2.2$
			G grade			$\pm 0.5$		$\pm 4.5$
<b>NOISE</b>								
	Input bias current drift <sup>(2)</sup>	F grade			$\pm 1.5$	$\pm 40$	$\text{pA}/^\circ\text{C}$	
		G grade			$\pm 1.5$	$\pm 85$		
	Input voltage noise	$f = 1\text{ Hz}$ to $100\text{ Hz}$ <sup>(3)</sup>			85	150	$\text{nV}_{\text{rms}}$	
	Input current noise	$f = 1\text{ Hz}$ to $100\text{ Hz}$			45		$\text{pA}_{\text{rms}}$	
<b>INPUT VOLTAGE</b>								
V <sub>CM</sub>	Common-mode voltage range <sup>(4)</sup>			$\pm 13$	$\pm 14$		V	
		$T_A = -40^\circ\text{C}$ to $+85^\circ\text{C}$		$\pm 13$	$\pm 13.5$			
CMRR	Common-mode rejection ratio	$V_{CM} = \pm 13\text{ V}$		F grade		130	140	dB
				G grade		115	140	
		$V_{CM} = \pm 13\text{ V}$ $T_A = -40^\circ\text{C}$ to $+85^\circ\text{C}$		F grade		120	140	
				G grade		110	140	
<b>INPUT IMPEDANCE</b>								
R <sub>in</sub>	Input resistance	Differential mode <sup>(5)</sup>		F grade		26	45	M $\Omega$
				G grade		18.5	45	
		Common-mode			200	G $\Omega$		

## 6.5 Electrical Characteristics (续)

at  $T_A = 25^\circ\text{C}$ ,  $V_S = 30\text{ V}$  ( $\pm 15\text{ V}$ ),  $V_{\text{CM}} = V_{\text{OUT}} = V_S / 2$ , and  $R_L = 2\text{ k}\Omega$  connected to  $V_S / 2$  (unless otherwise noted)

PARAMETER		TEST CONDITIONS		MIN	TYP	MAX	UNIT
<b>OPEN-LOOP GAIN</b>							
$A_{\text{OL}}$	Open-loop voltage gain <sup>(6)</sup>	$-10\text{ V} \leq V_O \leq 10\text{ V}$	F grade	134	141		dB
			G grade	126	135		
		$-10\text{ V} \leq V_O \leq 10\text{ V}$ $T_A = -40^\circ\text{C}$ to $+85^\circ\text{C}$	F grade	126	135		
			G grade	120	132		
<b>FREQUENCY RESPONSE</b>							
$\text{BW}_{\text{CL}}$	Closed-loop bandwidth	$G = 1$		0.4	0.6		MHz
SR	Slew rate			0.1	0.3		V/ $\mu\text{s}$
<b>OUTPUT</b>							
$V_O$	Voltage output swing	$R_L \geq 2\text{ k}\Omega$		$\pm 13.5$	$\pm 14$		V
			$T_A = -40^\circ\text{C}$ to $+85^\circ\text{C}$		$\pm 12$	$\pm 13$	
		$R_L \geq 10\text{ k}\Omega$		$\pm 12.5$	$\pm 13$		
			$R_L \geq 1\text{ k}\Omega$		$\pm 12$	$\pm 12.5$	
$I_{\text{SC}}$	Short-circuit current				$\pm 35$		mA
$R_O$	Open-loop output resistance				60		$\Omega$
<b>POWER SUPPLY</b>							
	Power consumption	$I_O = 0\text{ A}$			40	60	mW
			$T_A = -40^\circ\text{C}$ to $+85^\circ\text{C}$		60	75	
$I_Q$	Quiescent current	$I_O = 0\text{ A}$			1.3	2	mA
			$T_A = -40^\circ\text{C}$ to $+85^\circ\text{C}$		2	2.5	

- (1) Long-term input offset voltage stability refers to the averaged trend line of  $V_{\text{OS}}$  vs time over extended periods after the first 30 days of operation. Excluding the initial hour of operation, changes in  $V_{\text{OS}}$  during the first 30 operating days are typically less than  $2\text{ }\mu\text{V}$ .
- (2) Specified by characterization.
- (3) Sample tested.
- (4) Specified CMRR test condition.
- (5) Specified by design.
- (6) To maintain high open-loop gain throughout the  $\pm 10\text{-V}$  output range,  $A_{\text{OL}}$  is tested at  $-10\text{ V} \leq V_O \leq 0\text{ V}$ ,  $0\text{ V} \leq V_O \leq +10\text{ V}$ , and  $-10\text{ V} \leq V_O \leq +10\text{ V}$ .

## 6.6 Typical Characteristics

at  $T_A = +25^\circ\text{C}$ ,  $V_S = \pm 15\text{ V}$  (unless otherwise noted)

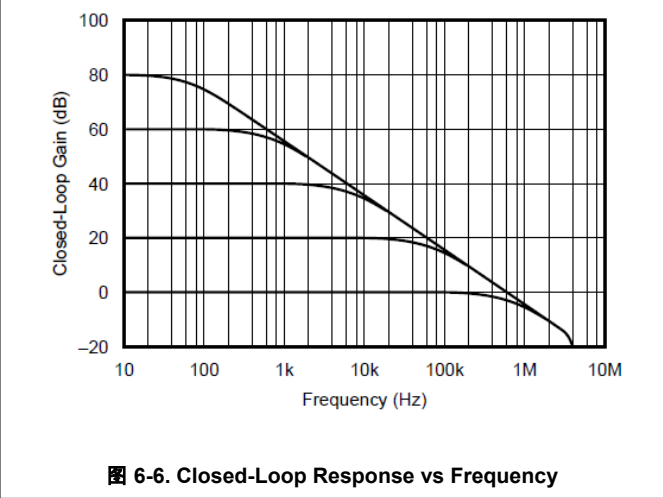
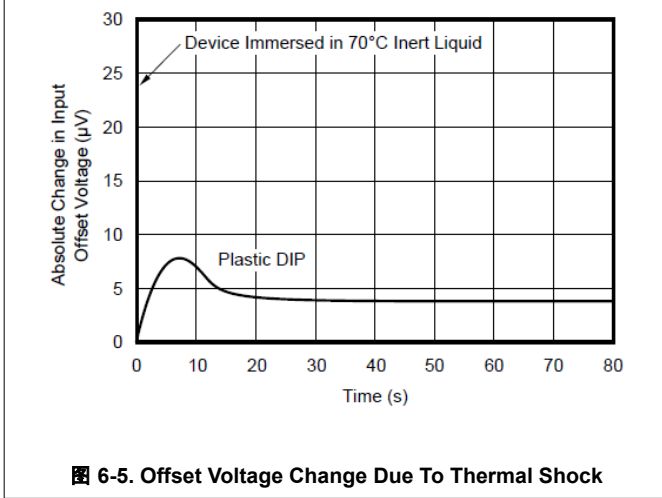
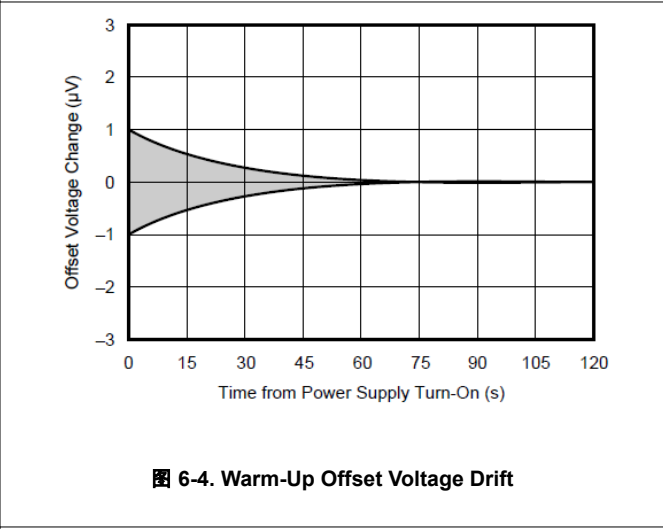
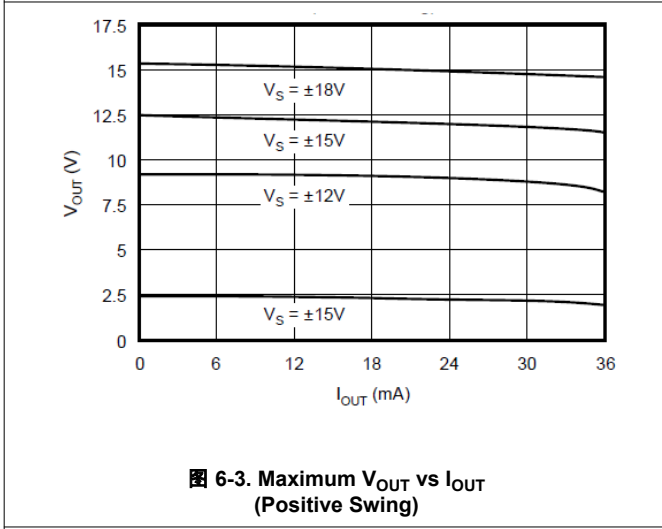
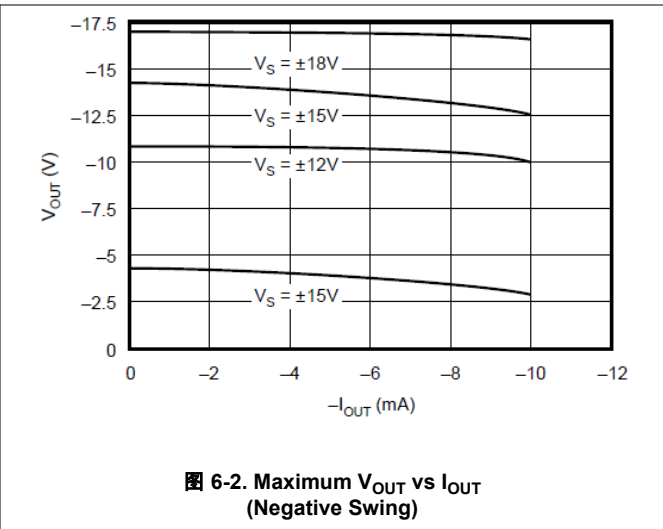
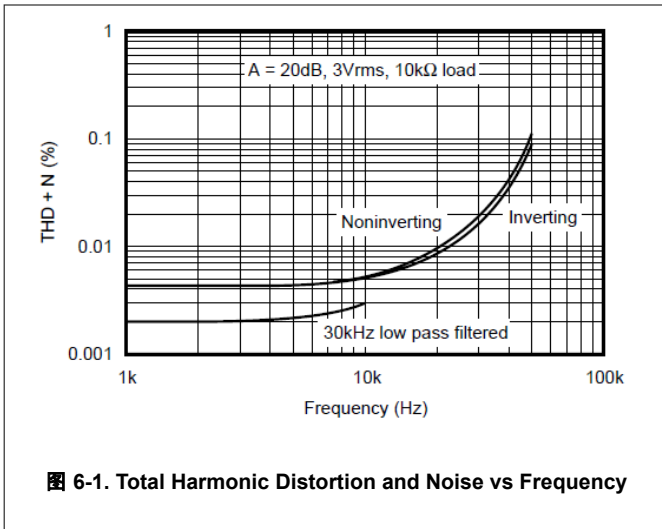

### 6.6 Typical Characteristics (continued)

at  $T_A = +25^\circ\text{C}$ ,  $V_S = \pm 15\text{ V}$  (unless otherwise noted)



图 6-7. Open-Loop Gain/Phase vs Frequency



图 6-8. CMRR vs Frequency

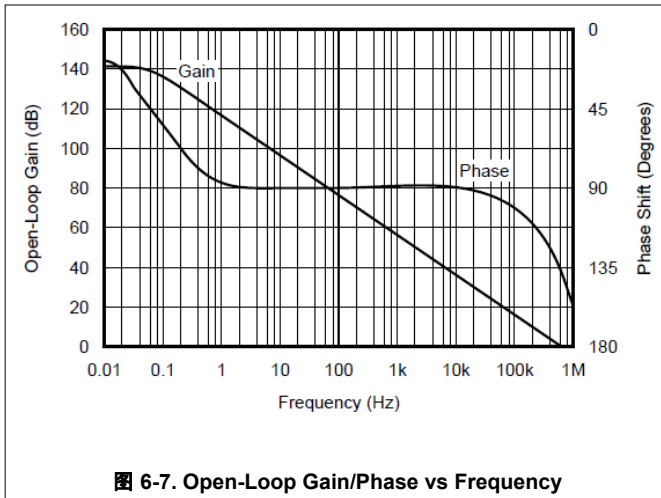

图 6-9. Power Supply Rejection vs Frequency

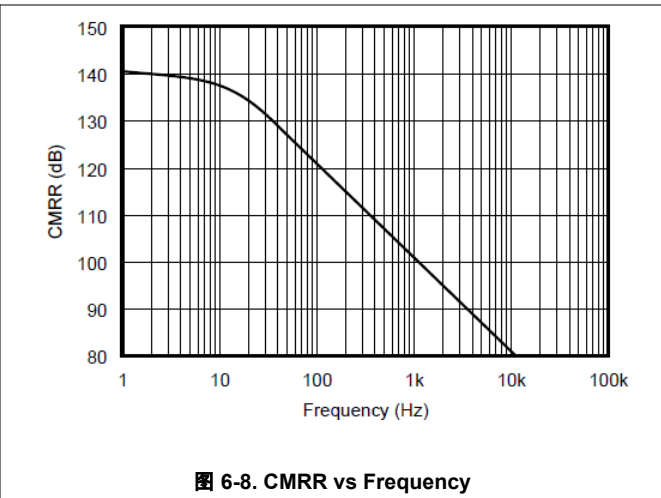

图 6-10. Input Bias and Input Offset Current vs Temperature

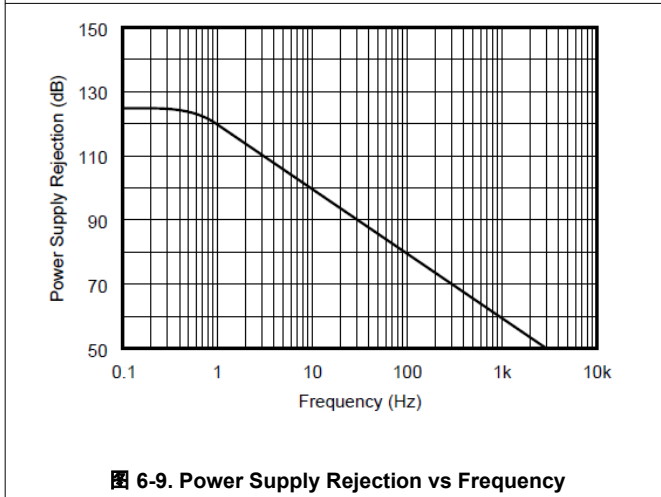

图 6-11. Total Noise vs Bandwidth (0.1Hz to Frequency Indicated)

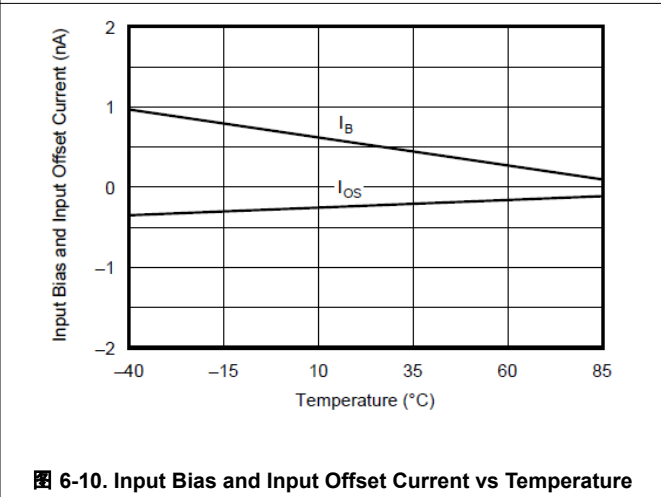

图 6-12. Input Noise Voltage Density vs frequency

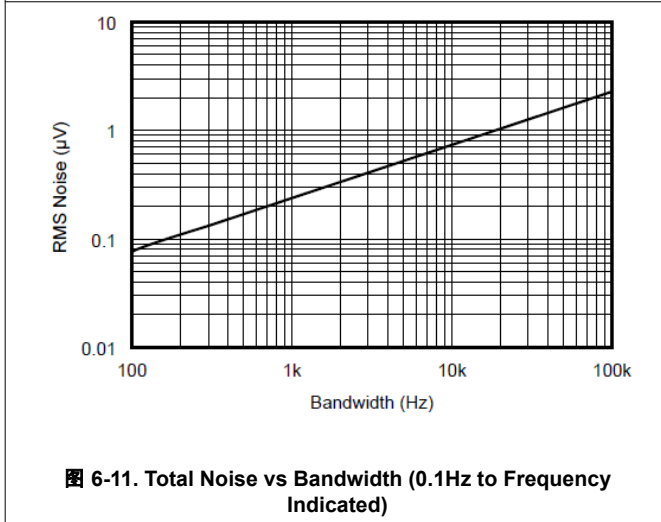

### 6.6 Typical Characteristics (continued)

at  $T_A = +25^\circ\text{C}$ ,  $V_S = \pm 15\text{ V}$  (unless otherwise noted)

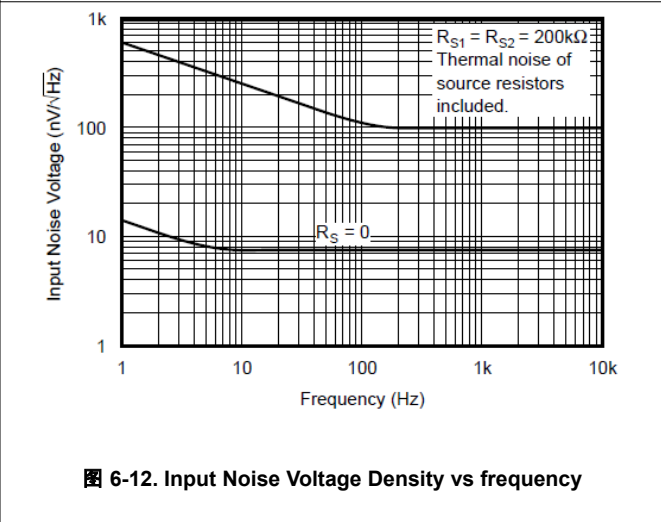

图 6-13. Maximum Output Swing vs Frequency



图 6-14. Power Consumption vs Power Supply

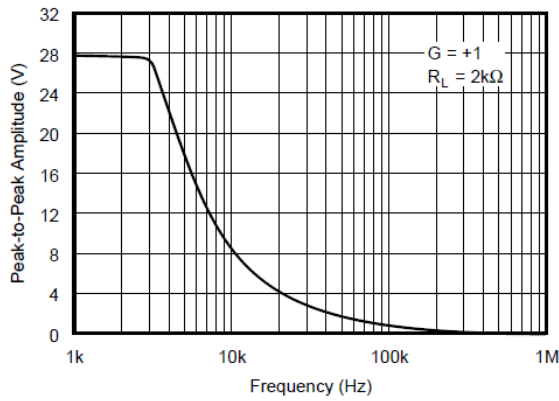

图 6-15. Maximum Output Voltage vs Load Resistance

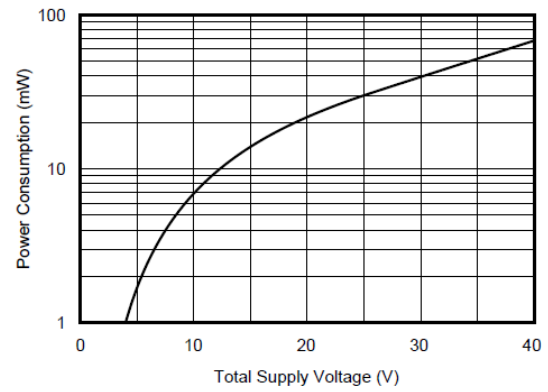

图 6-16. Output Short-Circuit Current vs Time

## 7 Application and Implementation

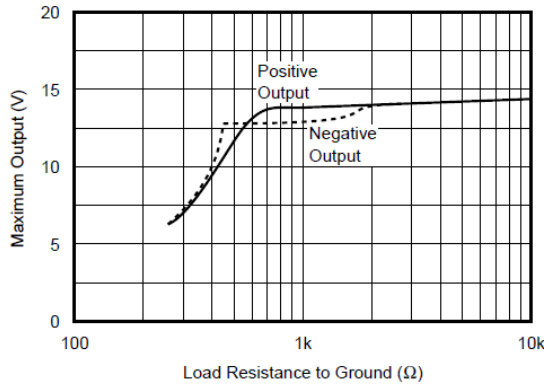
---

### 备注

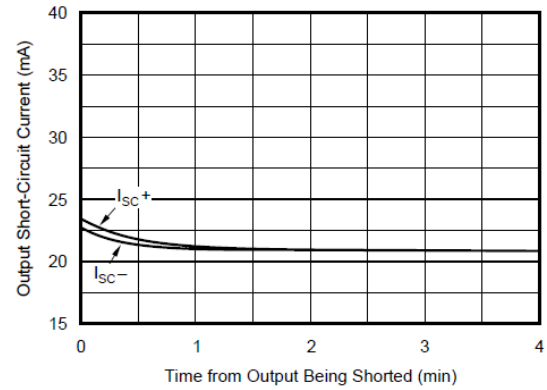
Information in the following applications sections is not part of the TI component specification, and TI does not warrant its accuracy or completeness. TI's customers are responsible for determining suitability of components for their purposes, as well as validating and testing their design implementation to confirm system functionality.

---

### 7.1 Application Information

The OPA177 is unity-gain stable, making this device easy to use and free from oscillations in the widest range of circuitry. Applications with noisy or high-impedance power-supply lines can require decoupling capacitors close to the device pins. In most cases, 0.1- $\mu$ F ceramic capacitors are adequate.

The OPA177 has very low offset voltage and drift. To achieve highest performance, optimize circuit layout and mechanical conditions. Offset voltage and drift degrades because of small thermoelectric potentials at the op-amp inputs. Connections of dissimilar metals generate thermal potential that can degrade the ultimate performance of the OPA177. To cancel these thermal potentials, make sure the thermal potentials are equal in both input pins.

1. Keep connections made to the two input pins close together.
2. Locate heat sources as far as possible from the critical input circuitry.
3. Shield the op amp and input circuitry from air currents, such as cooling fans.

#### 7.1.1 Offset Voltage Adjustment

The OPA177 has been laser-trimmed for low offset voltage and drift; therefore, most circuits do not require external adjustment. [图 7-1](#) shows the optional connection of an external potentiometer to adjust offset voltage. Do not use this adjustment to compensate for offsets created elsewhere in a system because this adjustment can introduce excessive temperature drift.

#### 7.1.2 Input Protection

The inputs of the OPA177 are protected with 500- $\Omega$  series input resistors and diode clamps as shown in the simplified circuit diagram on the front page. The inputs can withstand  $\pm 30$ -V differential inputs without damage. The protection diodes conduct current when the inputs are overdriven. This conducted current can disturb the slewing behavior of unity-gain follower applications, but does not damage the op amp. Some applications, such as programmable logic controllers (PLCs) require a robust input-protection design. An input-protection circuit can be implemented using four Schottky diodes; however, the temperature and voltage dependent leakage of the diodes can present undesirable nonlinear errors at the input. For applications requiring high precision and robust input protection, the [OPAx206](#) family of op amps are an excellent choice, offering integrated input overvoltage protection that eliminates the need for external clamping circuits.

#### 7.1.3 Noise Performance

The OPA177 noise performance is optimized for a circuit impedance range of 2 k $\Omega$  to 50 k $\Omega$ . Total noise in an application is a combination of the op-amp input voltage noise and input bias current noise reacting with circuit impedance. For applications with higher source impedance, the [OPAx828](#) and [OPAx140](#) FET-input op amps generally provide lower noise due to the inherently low input current noise. For low-impedance, low-noise applications, the [OPAx210](#) is an excellent choice because of the exceptionally low op-amp input-voltage noise.

### 7.1.4 Input Bias Current Cancellation

The input stage base current of the OPA177 is internally compensated with an equal and opposite cancellation current. The resulting input bias current is the difference between the input stage base current and the cancellation current. This residual input bias current can be positive or negative.

When the bias current is canceled in this manner, the input bias current and input offset current are approximately the same magnitude. As a result, there is no need to balance the dc resistance seen at the two input pins (图 7-2 和 图 7-3). A resistor added to balance the input resistances can actually increase offset and noise.

### 7.2 Typical Application

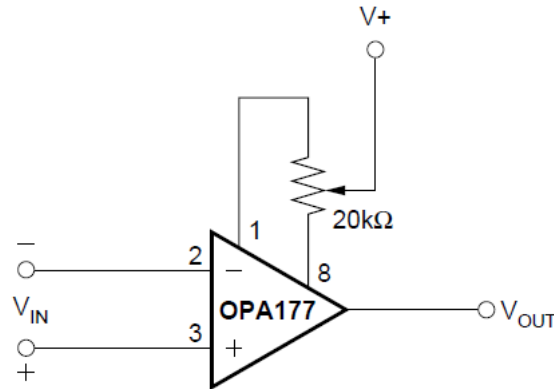

Trim range is approximately  $\pm 3.0$  mV.

图 7-1. Optional Offset Nulling Circuit

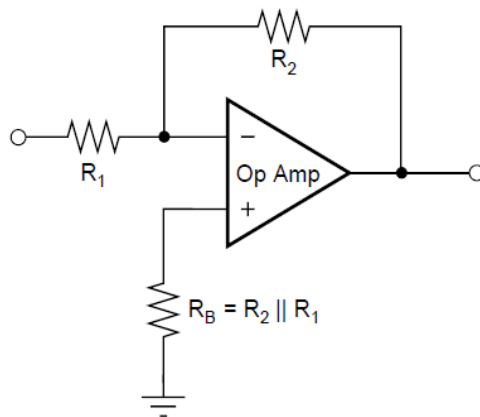

Conventional op amp with external bias current cancellation resistor.

图 7-2. Input Bias Current Cancellation With Conventional Op Amp

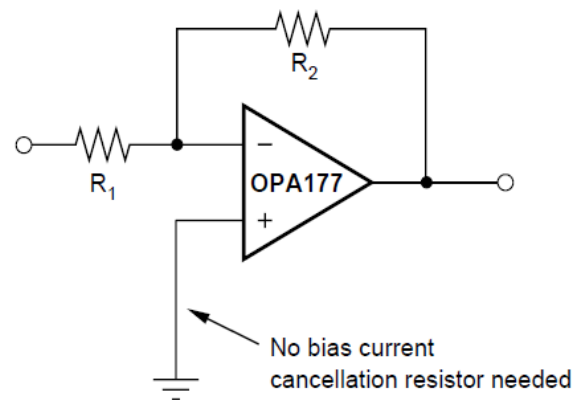

OPA177 with no external bias current cancellation resistor.

图 7-3. Input Bias Current Cancellation With OPA177

## 8 Device and Documentation Support

TI offers an extensive line of development tools. Tools and software to evaluate the performance of the device, generate code, and develop solutions are listed below.

### 8.1 器件支持

#### 8.1.1 开发支持

##### 8.1.1.1 PSpice® for TI

PSpice® for TI 是可帮助评估模拟电路性能的设计和仿真环境。在进行布局和制造之前创建子系统设计和原型解决方案，可降低开发成本并缩短上市时间。

##### 8.1.1.2 TINA-TI™ 仿真软件 (免费下载)

TINA-TI™ 仿真软件是一款简单易用、功能强大且基于 SPICE 引擎的电路仿真程序。TINA-TI 仿真软件是 TINA™ 软件的一款免费全功能版本，除了一系列无源和有源模型外，此版本软件还预先载入了一个宏模型库。TINA-TI 仿真软件提供所有传统的 SPICE 直流、瞬态和频域分析，以及其他设计功能。

TINA-TI 仿真软件提供全面的后处理能力，便于用户以多种方式获得结果，用户可从[设计工具和仿真网页免费下载](#)。虚拟仪器提供选择输入波形和探测电路节点、电压以及波形的能力，从而构建一个动态的快速启动工具。

---

#### 备注

必须安装 TINA 软件或者 TINA-TI 软件后才能使用这些文件。请从 [TINA-TI™ 软件文件夹](#) 中下载免费的 TINA-TI 仿真软件。

---

##### 8.1.1.3 DIP-Adapter-EVM

借助 [DIP-Adapter-EVM](#) 加快运算放大器的原型设计和测试，该 EVM 有助于快速轻松地连接小型表面贴装器件并且价格低廉。使用随附的 Samtec 端子板连接任何受支持的运算放大器，或者将这些端子板直接连接至现有电路。DIP-Adapter-EVM 套件支持以下业界通用封装：D 或 U (SOIC-8)、PW (TSSOP-8)、DGK (VSSOP-8)、DBV (SOT-23-6、SOT-23-5 和 SOT-23-3)、DCK (SC70-6 和 SC70-5) 和 DRL (SOT563-6)。

##### 8.1.1.4 DIYAMP-EVM

DIYAMP-EVM 是一款独特的评估模块 (EVM)，可提供真实的放大器电路，使用户能够快速评估设计概念并验证仿真。此 EVM 采用 3 种业界通用封装选项 (SC70、SOT23 和 SOIC) 并提供 12 种流行的放大器配置，包括放大器、滤波器、稳定性补偿以及同时适用于单电源和双电源的比较器配置。

##### 8.1.1.5 TI 参考设计

TI 参考设计是由 TI 的精密模拟应用专家创建的模拟解决方案。TI 参考设计提供了许多实用电路的工作原理、组件选择、仿真、完整印刷电路板 (PCB) 电路原理图和布局布线、物料清单以及性能测量结果。TI 参考设计可在线获取，网址为 <https://www.ti.com/reference-designs>。

##### 8.1.1.6 滤波器设计工具

[滤波器设计工具](#) 是一款简单、功能强大且便于使用的有源滤波器设计程序。利用滤波设计器，用户可使用精选 TI 运算放大器和 TI 供应商合作伙伴提供的无源器件来打造理想滤波器设计方案。

[设计工具和仿真网页](#) 以基于网络的工具形式提供 [滤波设计工具](#)。用户通过该工具可在短时间内完成多级有源滤波器解决方案的设计、优化和仿真。

### 8.2 接收文档更新通知

要接收文档更新通知，请导航至 [ti.com](https://www.ti.com) 上的器件产品文件夹。点击 [订阅更新](#) 进行注册，即可每周接收产品信息更改摘要。有关更改的详细信息，请查看任何已修订文档中包含的修订历史记录。

### 8.3 支持资源

[TI E2E™ 支持论坛](#) 是工程师的重要参考资料，可直接从专家获得快速、经过验证的解答和设计帮助。搜索现有解答或提出自己的问题可获得所需的快速设计帮助。

链接的内容由各个贡献者“按原样”提供。这些内容并不构成 TI 技术规范，并且不一定反映 TI 的观点；请参阅 TI 的《使用条款》。

#### 8.4 Trademarks

TINA-TI™ and TI E2E™ are trademarks of Texas Instruments.

TINA™ is a trademark of DesignSoft, Inc.

PSpice® is a registered trademark of Cadence Design Systems, Inc.

所有商标均为其各自所有者的财产。

#### 8.5 静电放电警告



静电放电 (ESD) 会损坏这个集成电路。德州仪器 (TI) 建议通过适当的预防措施处理所有集成电路。如果不遵守正确的处理和安装程序，可能会损坏集成电路。

ESD 的损坏小至导致微小的性能降级，大至整个器件故障。精密的集成电路可能更容易受到损坏，这是因为非常细微的参数更改都可能会导致器件与其发布的规格不相符。

#### 8.6 术语表

[TI 术语表](#) 本术语表列出并解释了术语、首字母缩略词和定义。

### 9 Mechanical, Packaging, and Orderable Information

The following pages include mechanical, packaging, and orderable information. This information is the most current data available for the designated devices. This data is subject to change without notice and revision of this document. For browser-based versions of this data sheet, refer to the left-hand navigation.

**PACKAGING INFORMATION**

Orderable Device	Status (1)	Package Type	Package Drawing	Pins	Package Qty	Eco Plan (2)	Lead finish/ Ball material (6)	MSL Peak Temp (3)	Op Temp (°C)	Device Marking (4/5)	Samples
OPA177FP	OBSOLETE	PDIP	P	8		TBD	Call TI	Call TI		OPA177FP	
OPA177GP	OBSOLETE	PDIP	P	8		TBD	Call TI	Call TI	-40 to 85	OPA177GP	
OPA177GS	ACTIVE	SOIC	D	8	75	RoHS & Green	NIPDAU	Level-3-260C-168 HR		OPA 177GS	Samples
OPA177GS/2K5	ACTIVE	SOIC	D	8	2500	RoHS & Green	NIPDAU	Level-3-260C-168 HR		OPA 177GS	Samples

(1) The marketing status values are defined as follows:

**ACTIVE:** Product device recommended for new designs.

**LIFEBUY:** TI has announced that the device will be discontinued, and a lifetime-buy period is in effect.

**NRND:** Not recommended for new designs. Device is in production to support existing customers, but TI does not recommend using this part in a new design.

**PREVIEW:** Device has been announced but is not in production. Samples may or may not be available.

**OBSOLETE:** TI has discontinued the production of the device.

(2) **RoHS:** TI defines "RoHS" to mean semiconductor products that are compliant with the current EU RoHS requirements for all 10 RoHS substances, including the requirement that RoHS substance do not exceed 0.1% by weight in homogeneous materials. Where designed to be soldered at high temperatures, "RoHS" products are suitable for use in specified lead-free processes. TI may reference these types of products as "Pb-Free".

**RoHS Exempt:** TI defines "RoHS Exempt" to mean products that contain lead but are compliant with EU RoHS pursuant to a specific EU RoHS exemption.

**Green:** TI defines "Green" to mean the content of Chlorine (Cl) and Bromine (Br) based flame retardants meet JS709B low halogen requirements of <=1000ppm threshold. Antimony trioxide based flame retardants must also meet the <=1000ppm threshold requirement.

(3) MSL, Peak Temp. - The Moisture Sensitivity Level rating according to the JEDEC industry standard classifications, and peak solder temperature.

(4) There may be additional marking, which relates to the logo, the lot trace code information, or the environmental category on the device.

(5) Multiple Device Markings will be inside parentheses. Only one Device Marking contained in parentheses and separated by a "~" will appear on a device. If a line is indented then it is a continuation of the previous line and the two combined represent the entire Device Marking for that device.

(6) Lead finish/Ball material - Orderable Devices may have multiple material finish options. Finish options are separated by a vertical ruled line. Lead finish/Ball material values may wrap to two lines if the finish value exceeds the maximum column width.

**Important Information and Disclaimer:** The information provided on this page represents TI's knowledge and belief as of the date that it is provided. TI bases its knowledge and belief on information provided by third parties, and makes no representation or warranty as to the accuracy of such information. Efforts are underway to better integrate information from third parties. TI has taken and continues to take reasonable steps to provide representative and accurate information but may not have conducted destructive testing or chemical analysis on incoming materials and chemicals. TI and TI suppliers consider certain information to be proprietary, and thus CAS numbers and other limited information may not be available for release.

In no event shall TI's liability arising out of such information exceed the total purchase price of the TI part(s) at issue in this document sold by TI to Customer on an annual basis.

**TAPE AND REEL INFORMATION**

**QUADRANT ASSIGNMENTS FOR PIN 1 ORIENTATION IN TAPE**

\*All dimensions are nominal

Device	Package Type	Package Drawing	Pins	SPQ	Reel Diameter (mm)	Reel Width W1 (mm)	A0 (mm)	B0 (mm)	K0 (mm)	P1 (mm)	W (mm)	Pin1 Quadrant
OPA177GS/2K5	SOIC	D	8	2500	330.0	12.4	6.4	5.2	2.1	8.0	12.0	Q1
OPA177GS/2K5	SOIC	D	8	2500	330.0	12.4	6.4	5.2	2.1	8.0	12.0	Q1



**TAPE AND REEL BOX DIMENSIONS**

\*All dimensions are nominal

Device	Package Type	Package Drawing	Pins	SPQ	Length (mm)	Width (mm)	Height (mm)
OPA177GS/2K5	SOIC	D	8	2500	356.0	356.0	35.0
OPA177GS/2K5	SOIC	D	8	2500	353.0	353.0	32.0

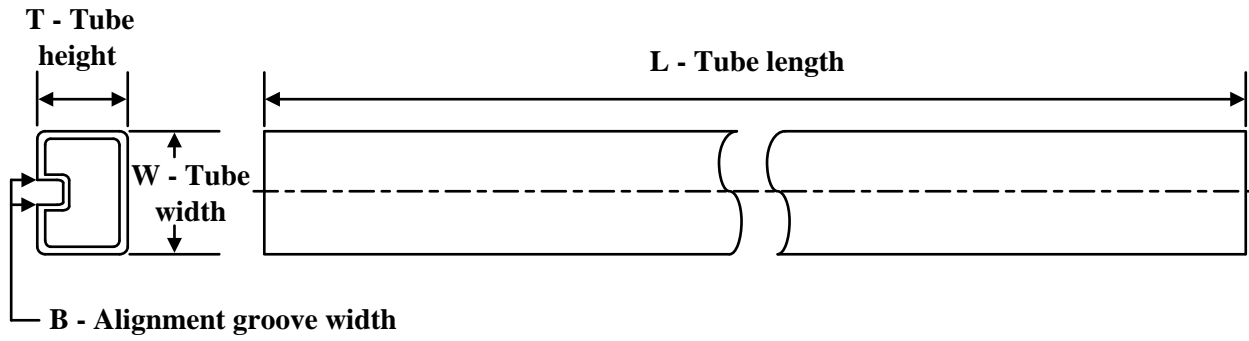
**TUBE**

\*All dimensions are nominal

Device	Package Name	Package Type	Pins	SPQ	L (mm)	W (mm)	T (μm)	B (mm)
OPA177GS	D	SOIC	8	75	506.6	8	3940	4.32

## 重要声明和免责声明

TI“按原样”提供技术和可靠性数据（包括数据表）、设计资源（包括参考设计）、应用或其他设计建议、网络工具、安全信息和其他资源，不保证没有瑕疵且不做任何明示或暗示的担保，包括但不限于对适销性、某特定用途方面的适用性或不侵犯任何第三方知识产权的暗示担保。

这些资源可供使用 TI 产品进行设计的熟练开发人员使用。您将自行承担以下全部责任：(1) 针对您的应用选择合适的 TI 产品，(2) 设计、验证并测试您的应用，(3) 确保您的应用满足相应标准以及任何其他功能安全、信息安全、监管或其他要求。

这些资源如有变更，恕不另行通知。TI 授权您仅可将这些资源用于研发本资源所述的 TI 产品的应用。严禁对这些资源进行其他复制或展示。您无权使用任何其他 TI 知识产权或任何第三方知识产权。您应全额赔偿因在这些资源的使用中对 TI 及其代表造成的任何索赔、损害、成本、损失和债务，TI 对此概不负责。

TI 提供的产品受 [TI 的销售条款](#) 或 [ti.com](#) 上其他适用条款/TI 产品随附的其他适用条款的约束。TI 提供这些资源并不会扩展或以其他方式更改 TI 针对 TI 产品发布的适用的担保或担保免责声明。

TI 反对并拒绝您可能提出的任何其他或不同的条款。

邮寄地址：Texas Instruments, Post Office Box 655303, Dallas, Texas 75265

Copyright © 2024，德州仪器 (TI) 公司