

## 1 Digital Media System-on-Chip (DMSoC)

### 1.1 Features

- **High-Performance Digital Media SoC**
  - 594-MHz C64x+™ Clock Rates
  - 297-MHz ARM926EJ-S™ Clock Rates
  - Eight 32-Bit C64x+ Instructions/Cycle
  - 4752 C64x+ MIPS
  - Fully Software-Compatible With C64x / ARM9™
  - Extended Temperature Devices Available
- **Advanced Very-Long-Instruction-Word (VLIW) TMS320C64x+™ DSP Core**
  - Eight Highly Independent Functional Units
    - Six ALUs (32-/40-Bit), Each Supports Single 32-Bit, Dual 16-Bit, or Quad 8-Bit Arithmetic per Clock Cycle
    - Two Multipliers Support Four 16 x 16-Bit Multiplies (32-Bit Results) per Clock Cycle or Eight 8 x 8-Bit Multiplies (16-Bit Results) per Clock Cycle
  - Load-Store Architecture With Non-Aligned Support
  - 64 32-Bit General-Purpose Registers
  - Instruction Packing Reduces Code Size
  - All Instructions Conditional
  - Additional C64x+™ Enhancements
    - Protected Mode Operation
    - Exceptions Support for Error Detection and Program Redirection
    - Hardware Support for Modulo Loop Operation
- **C64x+ Instruction Set Features**
  - Byte-Addressable (8-/16-/32-/64-Bit Data)
  - 8-Bit Overflow Protection
  - Bit-Field Extract, Set, Clear
  - Normalization, Saturation, Bit-Counting
  - Compact 16-Bit Instructions
  - Additional Instructions to Support Complex Multiplies
- **C64x+ L1/L2 Memory Architecture**
  - 32K-Byte L1P Program RAM/Cache (Direct Mapped)
  - 80K-Byte L1D Data RAM/Cache (2-Way Set-Associative)
  - 64K-Byte L2 Unified Mapped RAM/Cache (Flexible RAM/Cache Allocation)
- **ARM926EJ-S Core**
  - Support for 32-Bit and 16-Bit (Thumb® Mode) Instruction Sets
  - DSP Instruction Extensions and Single Cycle MAC
  - ARM® Jazelle® Technology
  - EmbeddedICE-RT™ Logic for Real-Time Debug
- **ARM9 Memory Architecture**
  - 16K-Byte Instruction Cache
  - 8K-Byte Data Cache
  - 16K-Byte RAM
  - 8K-Byte ROM
- **Embedded Trace Buffer™ (ETB11™) With 4KB Memory for ARM9 Debug**
- **Endianness: Little Endian for ARM and DSP**
- **Video Processing Subsystem**
  - Front End Provides:
    - CCD and CMOS Imager Interface
    - BT.601/BT.656 Digital YCbCr 4:2:2 (8-/16-Bit) Interface
    - Preview Engine for Real-Time Image Processing
    - Glueless Interface to Common Video Decoders
    - Histogram Module
    - Auto-Exposure, Auto-White Balance and Auto-Focus Module
    - Resize Engine
      - Resize Images From 1/4x to 4x
      - Separate Horizontal/Vertical Control
  - Back End Provides:
    - Hardware On-Screen Display (OSD)
    - Four 54-MHz DACs for a Combination of
      - Composite NTSC/PAL Video
      - Luma/Chroma Separate Video (S-video)
      - Component (YPbPr or RGB) Video (Progressive)
    - Digital Output
      - 8-/16-bit YUV or up to 24-Bit RGB
      - HD Resolution
      - Up to 2 Video Windows



Please be aware that an important notice concerning availability, standard warranty, and use in critical applications of Texas Instruments semiconductor products and disclaimers thereto appears at the end of this document.

All trademarks are the property of their respective owners.

- **External Memory Interfaces (EMIFs)**
  - 32-Bit DDR2 SDRAM Memory Controller With 256M-Byte Address Space (1.8-V I/O)
  - Asynchronous 16-Bit Wide EMIF (EMIFA) With 128M-Byte Address Reach
    - **Flash Memory Interfaces**
      - NOR (8-/16-Bit-Wide Data)
      - NAND (8-/16-Bit-Wide Data)
- **Flash Card Interfaces**
  - Multimedia Card (MMC)/Secure Digital (SD) with Secure Data I/O (SDIO)
  - Compact Flash Controller With True IDE Mode
  - SmartMedia
- **Enhanced Direct-Memory-Access (EDMA) Controller (64 Independent Channels)**
- **Two 64-Bit General-Purpose Timers (Each Configurable as Two 32-Bit Timers)**
- **One 64-Bit Watch Dog Timer**
- **Three UARTs (One with RTS and CTS Flow Control)**
- **One Serial Peripheral Interface (SPI) With Two Chip-Selects**
- **Master/Slave Inter-Integrated Circuit (I<sup>2</sup>C Bus™)**
- **Audio Serial Port (ASP)**
  - I2S
  - AC97 Audio Codec Interface
  - Standard Voice Codec Interface (AIC12)
- **10/100 Mb/s Ethernet MAC (EMAC)**
  - IEEE 802.3 Compliant
  - Media Independent Interface (MII)
- **VLYNQ™ Interface (FPGA Interface)**
- **Host Port Interface (HPI) with 16-Bit Multiplexed Address/Data**
- **USB Port With Integrated 2.0 PHY**
  - USB 2.0 High-/Full-Speed (480-Mbps) Client
  - USB 2.0 High-/Full-/Low-Speed Host (Mini-Host, Supporting One External Device)
- **Three Pulse Width Modulator (PWM) Outputs**
- **On-Chip ARM ROM Bootloader (RBL) to Boot From NAND Flash or UART**
- **ATA/ATAPI I/F (ATA/ATAPI-6 Specification)**
- **Individual Power-Saving Modes for ARM/DSP**
- **Flexible PLL Clock Generators**
- **IEEE-1149.1 (JTAG) Boundary-Scan-Compatible**
- **Up to 71 General-Purpose I/O (GPIO) Pins (Multiplexed With Other Device Functions)**
- **361-Pin Pb-Free BGA Package (ZWT Suffix), 0.8-mm Ball Pitch**
- **0.09-μm/6-Level Cu Metal Process (CMOS)**
- **3.3-V and 1.8-V I/O, 1.2-V Internal**
- **Applications:**
  - Digital Media
  - Networked Media Encode/Decode
  - Video Imaging

## 1.2 SUPPORTS DEFENSE, AEROSPACE, AND MEDICAL APPLICATIONS

- **Controlled Baseline**
- **One Assembly/Test Site**
- **One Fabrication Site**
- **Available in A-Temp (–40°C/105°C) Temperature Range<sup>(1)</sup>**
- **Extended Product Life Cycle**
- **Extended Product-Change Notification**
- **Product Traceability**

(1) Additional temperature ranges are available - contact factory

### 1.3 Description

The TMS320DM6446 devices (also referenced as DM6446 and including the SM320DM6446) leverages TI's DaVinci™ technology to meet the networked media encode and decode application processing needs of next-generation embedded devices.

The DM6446 enables OEMs and ODMs to quickly bring to market devices featuring robust operating systems support, rich user interfaces, high processing performance, and long battery life through the maximum flexibility of a fully integrated mixed processor solution.

The dual-core architecture of the DM6446 provides benefits of both DSP and Reduced Instruction Set Computer (RISC) technologies, incorporating a high-performance TMS320C64x+™ DSP core and an ARM926EJ-S core.

The ARM926EJ-S is a 32-bit RISC processor core that performs 32-bit or 16-bit instructions and processes 32-bit, 16-bit, or 8-bit data. The core uses pipelining so that all parts of the processor and memory system can operate continuously.

The ARM core incorporates:

- A coprocessor 15 (CP15) and protection module
- Data and program Memory Management Units (MMUs) with table look-aside buffers.
- Separate 16K-byte instruction and 8K-byte data caches. Both are four-way associative with virtual index virtual tag (VIVT).

The TMS320C64x+™ DSPs are the highest-performance fixed-point DSP generation in the TMS320C6000™ DSP platform. It is based on an enhanced version of the second-generation high-performance, advanced very-long-instruction-word (VLIW) architecture developed by Texas Instruments (TI), making these DSP cores an excellent choice for digital media applications. The C64x is a code-compatible member of the C6000™ DSP platform. The TMS320C64x+ DSP is an enhancement of the C64x+™ DSP with added functionality and an expanded instruction set.

Any reference to the C64x™ DSP or C64x™ CPU also applies, unless otherwise noted, to the C64x+™ DSP and C64x+™ CPU, respectively.

With performance of up to 4752 million instructions per second (MIPS) at a clock rate of 594 MHz, the C64x+ core offers solutions to high-performance DSP programming challenges. The DSP core possesses the operational flexibility of high-speed controllers and the numerical capability of array processors. The C64x+ DSP core processor has 64 general-purpose registers of 32-bit word length and eight highly independent functional units—two multipliers for a 32-bit result and six arithmetic logic units (ALUs). The eight functional units include instructions to accelerate the performance in video and imaging applications. The DSP core can produce four 16-bit multiply-accumulates (MACs) per cycle for a total of 2376 million MACs per second (MMACS), or eight 8-bit MACs per cycle for a total of 4752 MMACS. For more details on the C64x+ DSP, see the *TMS320C64x/C64x+ DSP CPU and Instruction Set Reference Guide* (literature number SPRU732).

The DM6446 also has application-specific hardware logic, on-chip memory, and additional on-chip peripherals similar to the other C6000 DSP platform devices. The DM6446 core uses a two-level cache-based architecture. The Level 1 program cache (L1P) is a 256K-bit direct mapped cache and the Level 1 data cache (L1D) is a 640K-bit 2-way set-associative cache. The Level 2 memory/cache (L2) consists of an 512K-bit memory space that is shared between program and data space. L2 memory can be configured as mapped memory, cache, or combinations of the two.

The peripheral set includes: 2 configurable video ports; a 10/100 Mb/s Ethernet MAC (EMAC) with a Management Data Input/Output (MDIO) module; an inter-integrated circuit (I2C) Bus interface; one audio serial port (ASP); 2 64-bit general-purpose timers each configurable as 2 independent 32-bit timers; 1 64-bit watchdog timer; up to 71-pins of general-purpose input/output (GPIO) with programmable interrupt/event generation modes, multiplexed with other peripherals; 3 UARTs with hardware handshaking support on 1 UART; 3 pulse width modulator (PWM) peripherals; and 2 external memory interfaces: an asynchronous external memory interface (EMIFA) for slower memories/peripherals, and a higher speed synchronous memory interface for DDR2.

The DM6446 device includes a Video Processing Subsystem (VPSS) with two configurable video/imaging peripherals: 1 Video Processing Front-End (VPFE) input used for video capture, 1 Video Processing Back-End (VPBE) output with imaging co-processor (VICP) used for display.

The Video Processing Front-End (VPFE) is comprised of a CCD Controller (CCDC), a Preview Engine (Previewer), Histogram Module, Auto-Exposure/White Balance/Focus Module (H3A), and Resizer. The CCDC is capable of interfacing to common video decoders, CMOS sensors, and Charge Coupled Devices (CCDs). The Previewer is a real-time image processing engine that takes raw imager data from a CMOS sensor or CCD and converts from an RGB Bayer Pattern to YUV4:2:2. The Histogram and H3A modules provide statistical information on the raw color data for use by the DM6446. The Resizer accepts image data for separate horizontal and vertical resizing from 1/4x to 4x in increments of 256/N, where N is between 64 and 1024.

The Video Processing Back-End (VPBE) is comprised of an On-Screen Display Engine (OSD) and a Video Encoder (VENC). The OSD engine is capable of handling 2 separate video windows and 2 separate OSD windows. Other configurations include 2 video windows, 1 OSD window, and 1 attribute window allowing up to 8 levels of alpha blending. The VENC provides four analog DACs that run at 54 MHz, providing a means for composite NTSC/PAL video, S-Video, and/or Component video output. The VENC also provides up to 24 bits of digital output to interface to RGB888 devices. The digital output is capable of 8/16-bit BT.656 output and/or CCIR.601 with separate horizontal and vertical syncs.

The Ethernet Media Access Controller (EMAC) provides an efficient interface between the DM644x and the network. The DM6446 EMAC support both 10Base-T and 100Base-TX, or 10 Mbits/second (Mbps) and 100 Mbps in either half- or full-duplex mode, with hardware flow control and quality of service (QOS) support.

The Management Data Input/Output (MDIO) module continuously polls all 32 MDIO addresses in order to enumerate all PHY devices in the system. Once a PHY candidate has been selected by the ARM, the MDIO module transparently monitors its link state by reading the PHY status register. Link change events are stored in the MDIO module and can optionally interrupt the ARM, allowing the ARM to poll the link status of the device without continuously performing costly MDIO accesses.

The HPI, I2C, SPI, USB2.0, and VLYNQ ports allow DM6446 to easily control peripheral devices and/or communicate with host processors. The DM6446 also provides multimedia card support, MMC/SD, with SDIO support.

The DM6446 also includes a Video/Imaging Co-processor (VICP) to offload many video and imaging processing tasks from the DSP core, making more DSP MIPS available for common video and imaging algorithms. For more information on the VICP enhanced codecs, such as H.264 and MPEG4, please contact your nearest TI sales representative.

The rich peripheral set provides the ability to control external peripheral devices and communicate with external processors. For details on each of the peripherals, see the related sections later in this document and the associated peripheral reference guides.

The DM6446 has a complete set of development tools for both the ARM and DSP. These include C compilers, a DSP assembly optimizer to simplify programming and scheduling, and a Windows™ debugger interface for visibility into source code execution.

### 1.4 Functional Block Diagram

Figure 1-1 shows the functional block diagram of the device.

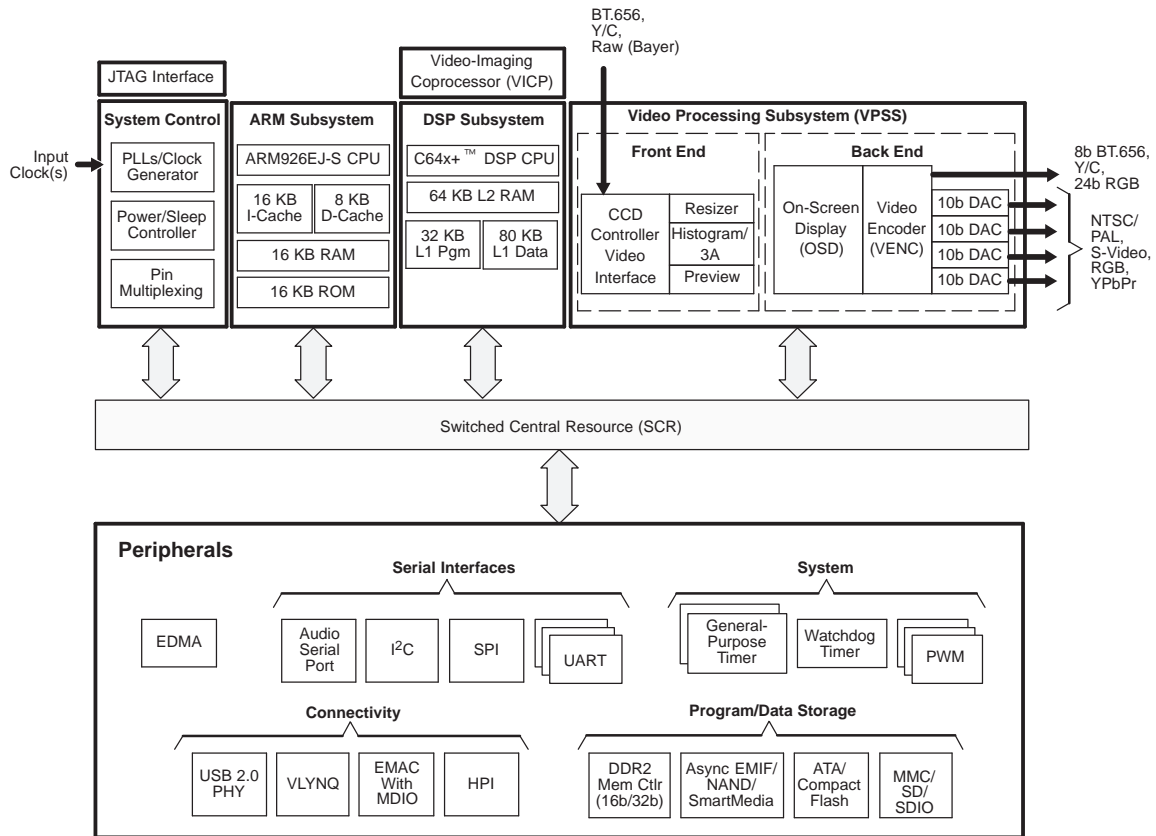

Figure 1-1. TMS320DM6446 Functional Block Diagram

**Contents**

<b>1</b>	<b>Digital Media System-on-Chip (DMSoC)</b> .....	<b>1</b>	6.1	Parameter Information .....	<b>86</b>
1.1	Features .....	<b>1</b>	6.2	Recommended Clock and Control Signal Transition Behavior .....	<b>87</b>
1.2	SUPPORTS DEFENSE, AEROSPACE, AND MEDICAL APPLICATIONS .....	<b>2</b>	6.3	Power Supplies.....	<b>87</b>
1.3	Description .....	<b>3</b>	6.4	Reset .....	<b>97</b>
1.4	Functional Block Diagram .....	<b>5</b>	6.5	External Clock Input From MXI/CLKIN Pin .....	<b>100</b>
<b>2</b>	<b>Device Overview</b> .....	<b>6</b>	6.6	Clock PLLs .....	<b>102</b>
2.1	Device Characteristics .....	<b>6</b>	6.7	Interrupts .....	<b>110</b>
2.2	Device Compatibility .....	<b>8</b>	6.8	General-Purpose Input/Output (GPIO).....	<b>117</b>
2.3	ARM Subsystem.....	<b>8</b>	6.9	Enhanced Direct Memory Access (EDMA) Controller.....	<b>120</b>
2.4	DSP Subsystem .....	<b>12</b>	6.10	External Memory Interface (EMIF).....	<b>132</b>
2.5	Memory Map Summary .....	<b>16</b>	6.11	ATA/CF .....	<b>140</b>
2.6	Pin Assignments .....	<b>19</b>	6.12	MMC/SD/SDIO .....	<b>153</b>
2.7	Terminal Functions .....	<b>24</b>	6.13	Video Processing Sub-System (VPSS) Overview .	<b>156</b>
2.8	Device Support .....	<b>56</b>	6.14	Host-Port Interface (HPI).....	<b>179</b>
<b>3</b>	<b>Device Configurations</b> .....	<b>59</b>	6.15	USB 2.0 .....	<b>182</b>
3.1	System Module Registers .....	<b>59</b>	6.16	Universal Asynchronous Receiver/Transmitter (UART) .....	<b>191</b>
3.2	Power Considerations .....	<b>59</b>	6.17	Serial Peripheral Interface (SPI) .....	<b>194</b>
3.3	Bootmode .....	<b>60</b>	6.18	Inter-Integrated Circuit (I2C) .....	<b>198</b>
3.4	Configurations at Reset .....	<b>64</b>	6.19	Audio Serial Port (ASP) .....	<b>202</b>
3.5	Configurations After Reset .....	<b>68</b>	6.20	Ethernet Media Access Controller (EMAC) .....	<b>206</b>
3.6	Emulation Control .....	<b>79</b>	6.21	Management Data Input/Output (MDIO).....	<b>213</b>
<b>4</b>	<b>System Interconnect</b> .....	<b>81</b>	6.22	Timer .....	<b>215</b>
4.1	System Interconnect Block Diagram .....	<b>82</b>	6.23	Pulse Width Modulator (PWM).....	<b>217</b>
<b>5</b>	<b>Device Operating Conditions</b> .....	<b>83</b>	6.24	VLYNQ .....	<b>219</b>
5.1	Absolute Maximum Ratings Over Operating Case Temperature Range (Unless Otherwise Noted) .....	<b>83</b>	6.25	IEEE 1149.1 JTAG .....	<b>223</b>
5.2	Recommended Operating Conditions .....	<b>84</b>	<b>7</b>	<b>Mechanical Packaging and Orderable Information</b> .....	<b>225</b>
5.3	Electrical Characteristics Over Recommended Ranges of Supply Voltage and Operating Case Temperature (Unless Otherwise Noted) .....	<b>85</b>	7.1	Thermal Data for ZWT .....	<b>225</b>
<b>6</b>	<b>Peripheral and Electrical Specifications</b> .....	<b>86</b>	7.1.1	Packaging Information.....	<b>225</b>

**2 Device Overview**

**2.1 Device Characteristics**

Table 2-1 provides an overview of the TMS320DM6446 SoC. The table shows significant features of the device, including the capacity of on-chip RAM, peripherals, internal peripheral bus frequency relative to the C64x+ DSP, and the package type with pin count.

**Table 2-1. Characteristics of the Processor**

HARDWARE FEATURES		DM6446
Peripherals  Not all peripherals pins are available at the same time (for more detail, see the Device Configurations section).	DDR2 Memory Controller	DDR2 (16/32-bit bus width)
	Asynchronous EMIF (EMIFA)	Asynchronous (8/16-bit bus width) RAM, Flash (NOR, NAND)
	Flash Cards	Compact Flash MMC/SD with secure data input/output (SDIO) SmartMedia/xD
	EDMA	64 independent channels 8 QDMA channels
	Timers	2 64-Bit General Purpose (each configurable as 2 separate 32-bit timers) 1 64-Bit Watchdog
	UART	3 (one with RTS and CTS flow control)
	SPI	1 (supports 2 slave devices)
	I <sup>2</sup> C	1 (Master/Slave)
	Audio Serial Port [ASP]	1
	10/100 Ethernet MAC with Management Data Input/Output	1
	VLYNQ	1
	HPI	1 (16-bit multiplexed address/data)
	General-Purpose Input/Output Port	Up to 71
	PWM	3 outputs
	ATA/CF	1 (ATA/ATAPI-6)
	Configurable Video Ports	1 Input (VPFE) 1 Output (VPBE)
	USB 2.0	High Speed Device High Speed Host
On-Chip Memory	Size (Bytes)	160KB RAM, 8KB ROM
	Organization	DSP <ul style="list-style-type: none"> <li>• 32KB L1 Program (L1P)/Cache (up to 32KB)</li> <li>• 80KB L1 Data (L1D)/Cache (up to 32KB)</li> <li>• 64KB Unified Mapped RAM/Cache (L2)</li> </ul> ARM <ul style="list-style-type: none"> <li>• 16KB I-cache</li> <li>• 8KB D-cache</li> <li>• 16KB RAM</li> <li>• 8KB ROM</li> </ul>
CPU ID + CPU Rev ID	Control Status Register (CSR.[31:16])	0x1000
C64x+ Megamodule Revision	Revision ID Register (MM_REVID[15:0]) (address location: 0x0181 2000)	0x0000 (Silicon Revision 1.3 and earlier) 0x0003 (Silicon Revision 2.1)
JTAG BSDL_ID	JTAGID Register (address location: 0x01C4 0028)	0x0B70 002F (Silicon Revision 1.3 and earlier) 0x1B70 002F (Silicon Revision 2.1)
CPU Frequency		DSP 594 MHz
		ARM 297 MHz
Cycle Time		DSP 1.68 ns
		ARM 3.37 ns
Voltage	Core (V)	1.2 V
	I/O (V)	1.8 V, 3.3 V
PLL Options	CLKIN frequency multiplier (27 MHz reference)	x1 (Bypass), x22
BGA Package	16 x 16 mm	361-Pin BGA (ZWT)
Process Technology	μm	0.09 μm

**Table 2-1. Characteristics of the Processor (continued)**

HARDWARE FEATURES		DM6446
Product Status <sup>(1)</sup>	Product Preview (PP), Advance Information (AI), or Production Data (PD)	PD

(1) PRODUCTION DATA information is current as of publication date. Products conform to specifications per the terms of Texas Instruments standard warranty. Production processing does not necessarily include testing of all parameters.

## 2.2 Device Compatibility

The ARM926EJ-S RISC CPU is compatible with other ARM9 CPUs from ARM Holdings plc.

The C64x+ DSP core is code-compatible with the C6000™ DSP platform and supports features of the C64x DSP family.

## 2.3 ARM Subsystem

The ARM Subsystem is designed to give the ARM926EJ-S (ARM9) master control of the device. In general, the ARM is responsible for configuration and control of the device; including the DSP Subsystem, the VPSS Subsystem, and a majority of the peripherals and external memories.

The ARM Subsystem includes the following features:

- ARM926EJ-S RISC processor
- ARMv5TEJ (32/16-bit) instruction set
- Little endian
- Co-Processor 15 (CP15)
- MMU
- 16KB Instruction cache
- 8KB Data cache
- Write Buffer
- 16KB Internal RAM (32-bit wide access)
- 8KB Internal ROM (ARM bootloader for non-EMIFA boot options)
- Embedded Trace Module and Embedded Trace Buffer (ETM/ETB)
- ARM Interrupt controller
- PLL Controller
- Power and Sleep Controller (PSC)
- System Module

### 2.3.1 ARM926EJ-S RISC CPU

The ARM Subsystem integrates the ARM926EJ-S processor. The ARM926EJ-S processor is a member of ARM9 family of general-purpose microprocessors. This processor is targeted at multi-tasking applications where full memory management, high performance, low die size, and low power are all important. The ARM926EJ-S processor supports the 32-bit ARM and 16 bit THUMB instruction sets, enabling the user to trade off between high performance and high code density. Specifically, the ARM926EJ-S processor supports the ARMv5TEJ instruction set, which includes features for efficient execution of Java byte codes, providing Java performance similar to Just in Time (JIT) Java interpreter, but without associated code overhead.

The ARM926EJ-S processor supports the ARM debug architecture and includes logic to assist in both hardware and software debug. The ARM926EJ-S processor has a Harvard architecture and provides a complete high performance subsystem, including:

- ARM926EJ -S integer core
- CP15 system control coprocessor



- Memory Management Unit (MMU)
- Separate instruction and data Caches
- Write buffer
- Separate instruction and data Tightly-Coupled Memories (TCMs) [internal RAM] interfaces
- Separate instruction and data AHB bus interfaces
- Embedded Trace Module and Embedded Trace Buffer (ETM/ETB)

For more complete details on the ARM9, refer to the ARM926EJ-S Technical Reference Manual, available at <http://www.arm.com>

### 2.3.2 CP15

The ARM926EJ-S system control coprocessor (CP15) is used to configure and control instruction and data caches, Tightly-Coupled Memories (TCMs), Memory Management Unit (MMU), and other ARM subsystem functions. The CP15 registers are programmed using the MRC and MCR ARM instructions, when the ARM is in a privileged mode such as supervisor or system mode.

### 2.3.3 MMU

The ARM926EJ-S MMU provides virtual memory features required by operating systems such as Linux®, Windows® CE, Ultron®, ThreadX®, etc. A single set of two level page tables stored in main memory is used to control the address translation, permission checks and memory region attributes for both data and instruction accesses. The MMU uses a single unified Translation Lookaside Buffer (TLB) to cache the information held in the page tables. The MMU features are:

- Standard ARM architecture v4 and v5 MMU mapping sizes, domains and access protection scheme.
- Mapping sizes are:
  - 1MB (sections)
  - 64KB (large pages)
  - 4KB (small pages)
  - 1KB (tiny pages)
- Access permissions for large pages and small pages can be specified separately for each quarter of the page (subpage permissions)
- Hardware page table walks
- Invalidate entire TLB, using CP15 register 8
- Invalidate TLB entry, selected by MVA, using CP15 register 8
- Lockdown of TLB entries, using CP15 register 10

### 2.3.4 Caches and Write Buffer

The size of the Instruction Cache is 16KB, Data cache is 8KB. Additionally, the Caches have the following features:

- Virtual index, virtual tag, and addressed using the Modified Virtual Address (MVA)
- Four-way set associative, with a cache line length of eight words per line (32-bytes per line) and with two dirty bits in the Dcache
- Dcache supports write-through and write-back (or copy back) cache operation, selected by memory region using the C and B bits in the MMU translation tables.
- Critical-word first cache refilling
- Cache lockdown registers enable control over which cache ways are used for allocation on a line fill, providing a mechanism for both lockdown, and controlling cache corruption
- Dcache stores the Physical Address TAG (PA TAG) corresponding to each Dcache entry in the TAG RAM for use during the cache line write-backs, in addition to the Virtual Address TAG stored in the TAG RAM. This means that the MMU is not involved in Dcache write-back operations, removing the possibility of TLB misses related to the write-back address.

- Cache maintenance operations provide efficient invalidation of, the entire Dcache or Icache, regions of the Dcache or Icache, and regions of virtual memory.

The write buffer is used for all writes to a noncachable bufferable region, write-through region and write misses to a write-back region. A separate buffer is incorporated in the Dcache for holding write-back for cache line evictions or cleaning of dirty cache lines. The main write buffer has 16-word data buffer and a four-address buffer. The Dcache write-back has eight data word entries and a single address entry.

### 2.3.5 *Tightly Coupled Memory (TCM)*

ARM internal RAM is provided for storing real-time and performance-critical code/data and the Interrupt Vector table. ARM internal ROM enables non-EMIFA boot options, such as NAND and UART. The RAM and ROM memories interfaced to the ARM926EJ-S via the tightly coupled memory interface that provides for separate instruction and data bus connections. Since the ARM TCM does not allow instructions on the D-TCM bus or data on the I-TCM bus, an arbiter is included so that both data and instructions can be stored in the internal RAM/ROM. The arbiter also allows accesses to the RAM/ROM from extra-ARM sources (e.g., EDMA or other masters). The ARM926EJ-S has built-in DMA support for direct accesses to the ARM internal memory from a non-ARM master. Because of the time-critical nature of the TCM link to the ARM internal memory, all accesses from non-ARM devices are treated as DMA transfers.

Instruction and Data accesses are differentiated via accessing different memory map regions, with the instruction region from 0x0000 through 0x7FFF and data from 0x8000 through 0xFFFF. The instruction region at 0x0000 and data region at 0x8000 map to the same physical 16KB TCM RAM. Placing the instruction region at 0x0000 is necessary to allow the ARM Interrupt Vector table to be placed at 0x0000, as required by the ARM architecture. The internal 16-KB RAM is split into two physical banks of 8KB each, which allows simultaneous instruction and data accesses to be accomplished if the code and data are in separate banks.

### 2.3.6 *Advanced High-Performance Bus (AHB)*

The ARM Subsystem uses the AHB port of the ARM926EJ-S to connect the ARM to the Config bus and the external memories. Arbiters are employed to arbitrate access to the separate D-AHB and I-AHB by the Config Bus and the external memories bus.

### 2.3.7 *Embedded Trace Macrocell (ETM) and Embedded Trace Buffer (ETB)*

To support real-time trace, the ARM926EJ-S processor provides an interface to enable connection of an Embedded Trace Macrocell (ETM). The ARM926ES-J Subsystem in the DM6446 also includes the Embedded Trace Buffer (ETB). The ETM consists of two parts:

- Trace Port provides real-time trace capability for the ARM9.
- Triggering facilities provide trigger resources, which include address and data comparators, counter, and sequencers.

The DM6446 trace port is not pinned out and is instead only connected to the Embedded Trace Buffer. The ETB has a 4KB buffer memory. ETB enabled debug tools are required to read/interpret the captured trace data.

### 2.3.8 *ARM Memory Mapping*

The ARM memory map is shown in [Section 2.5, Memory Map Summary](#) of this document. The ARM has access to memories shown in the following sections.

#### 2.3.8.1 *ARM Internal Memories*

The ARM has access to the following ARM internal memories:

- 16KB ARM Internal RAM on TCM interface, logically separated into two 8KB pages to allow simultaneous access on any given cycle if there are separate accesses for code (I-TCM bus) and data (D-TCM) to the different memory regions.
- 8KB ARM Internal ROM

### 2.3.8.2 External Memories

The ARM has access to the following external memories:

- DDR2 Synchronous DRAM
- Asynchronous EMIF / NOR Flash / NAND Flash
- ATA/CF
- Flash card devices:
  - MMC/SD with SDIO
  - xD
  - SmartMedia

### 2.3.8.3 DSP Memories

The ARM has access to the following DSP memories:

- L2 RAM
- L1P RAM
- L1D RAM

### 2.3.8.4 ARM-DSP Integration

DM6446 ARM and DSP integration features are as follows:

- DSP visibility from ARM's memory map, see [Section 2.5, Memory Map Summary](#), for details
- Boot Modes for DSP - see *Device Configurations* section, [Section 3.3.3, DSP Boot](#), for details
- ARM control of DSP boot / reset - see *Device Configurations* section, [Section 3.3.2, ARM Boot](#), for details
- ARM control of DSP isolation and powerdown / powerup - see [Section 3, Device Configurations](#), for details
- ARM & DSP Interrupts - see [Section 6.7.1, ARM CPU Interrupts](#), and [Section 6.7.2, DSP Interrupts](#), for details

## 2.3.9 Peripherals

The ARM9 has access to all of the peripherals on the DM6446 device with the exception of the VICP.

### 2.3.10 PLL Controller (PLLIC)

The ARM Subsystem includes the PLL Controller. The PLL Controller contains a set of registers for configuring DM6446's two internal PLLs (PLL1 and PLL2). The PLL Controller provides the following configuration and control:

- PLL Bypass Mode
- Set PLL multiplier parameters
- Set PLL divider parameters
- PLL power down
- Oscillator power down

The PLLs are briefly described in this document in the Clocking section. For more detailed information on the PLLs and PLL Controller register descriptions, see [Section 2.8.3, Documentation Support](#), of this document for the TMS320DM644x ARM Subsystem Reference Guide (literature number SPRUE14).

### 2.3.11 Power and Sleep Controller (PSC)

The ARM Subsystem includes the Power and Sleep Controller (PSC). Through register settings accessible by the ARM9, the PSC provides two levels of power savings: peripheral/module clock gating and power domain shut-off. Brief details on the PSC are given in [Section 6.3, Power Supplies](#). For more detailed information and complete register descriptions for the PSC, see [Section 2.8.3, Documentation Support](#), for the TMS320DM644x ARM Subsystem Reference Guide (literature number SPRUE14).

### 2.3.12 ARM Interrupt Controller (AINTC)

The ARM Interrupt Controller (AINTC) accepts device interrupts and maps them to either the ARM's IRQ (interrupt request) or FIQ (fast interrupt request). The ARM Interrupt Controller is briefly described in this document in the Interrupts section. For detailed information on the ARM Interrupt Controller, see [Section 2.8.3, Documentation Support](#) for the ARM Subsystem Guide.

### 2.3.13 System Module

The ARM Subsystem includes the System module. The System module consists of a set of registers for configuring and controlling a variety of system functions. For details and register descriptions for the System module, see [Section 3, Device Configurations](#) and see [Section 2.8.3, Documentation Support](#), for the TMS320DM644x ARM Subsystem Reference Guide (literature number SPRUE14).

### 2.3.14 Power Management

DM6446 has several means of managing power consumption. There is extensive use of clock gating, which reduces the power used by global device clocks and individual peripheral clocks. Clock management can be utilized to reduce clock frequencies in order to reduce switching power. For more details on power management techniques, see [Section 3, Device Configurations](#), [Section 6, Peripheral and Electrical Specifications](#), and see [Section 2.8.3, Documentation Support](#), for the TMS320DM644x ARM Subsystem Reference Guide (literature number SPRUE14).

DM6446 gives the programmer full flexibility to use any and all of the previously mentioned capabilities to customize an optimal power management strategy. Several typical power management scenarios are described in the following sections.

## 2.4 DSP Subsystem

The DSP Subsystem includes the following features:

- C64x+ DSP CPU
- 32KB L1 Program (L1P)/Cache (up to 32KB)
- 80KB L1 Data (L1D)/Cache (up to 32KB)
- 64KB Unified Mapped RAM/Cache (L2)
- Little endian

### 2.4.1 C64x+ DSP CPU Description

The C64x+ Central Processing Unit (CPU) consists of eight functional units, two register files, and two data paths as shown in [Figure 2-1](#). The two general-purpose register files (A and B) each contain 32 32-bit registers for a total of 64 registers. The general-purpose registers can be used for data or can be data address pointers. The data types supported include packed 8-bit data, packed 16-bit data, 32-bit data, 40-bit data, and 64-bit data. Values larger than 32 bits, such as 40-bit-long or 64-bit-long values are stored in register pairs, with the 32 LSBs of data placed in an even register and the remaining 8 or 32 MSBs in the next upper register (which is always an odd-numbered register).

The eight functional units (.M1, .L1, .D1, .S1, .M2, .L2, .D2, and .S2) are each capable of executing one instruction every clock cycle. The .M functional units perform all multiply operations. The .S and .L units perform a general set of arithmetic, logical, and branch functions. The .D units primarily load data from memory to the register file and store results from the register file into memory.

The C64x+ CPU extends the performance of the C64x core through enhancements and new features.

Each C64x+ .M unit can perform one of the following each clock cycle: one 32 x 32 bit multiply, one 16 x 32 bit multiply, two 16 x 16 bit multiplies, two 16 x 32 bit multiplies, two 16 x 16 bit multiplies with add/subtract capabilities, four 8 x 8 bit multiplies, four 8 x 8 bit multiplies with add operations, and four 16 x 16 multiplies with add/subtract capabilities (including a complex multiply). There is also support for Galois field multiplication for 8-bit and 32-bit data. Many communications algorithms such as FFTs and

modems require complex multiplication. The complex multiply (CMPY) instruction takes for 16-bit inputs and produces a 32-bit real and a 32-bit imaginary output. There are also complex multiplies with rounding capability that produces one 32-bit packed output that contain 16-bit real and 16-bit imaginary values. The 32 x 32 bit multiply instructions provide the extended precision necessary for audio and other high-precision algorithms on a variety of signed and unsigned 32-bit data types.

The .L or (Arithmetic Logic Unit) now incorporates the ability to do parallel add/subtract operations on a pair of common inputs. Versions of this instruction exist to work on 32-bit data or on pairs of 16-bit data performing dual 16-bit add and subtracts in parallel. There are also saturated forms of these instructions.

The C64x+ core enhances the .S unit in several ways. In the C64x core, dual 16-bit MIN2 and MAX2 comparisons were only available on the .L units. On the C64x+ core they are also available on the .S unit which increases the performance of algorithms that do searching and sorting. Finally, to increase data packing and unpacking throughput, the .S unit allows sustained high performance for the quad 8-bit/16-bit and dual 16-bit instructions. Unpack instructions prepare 8-bit data for parallel 16-bit operations. Pack instructions return parallel results to output precision including saturation support.

Other new features include:

- **SPLOOP** - A small instruction buffer in the CPU that aids in creation of software pipelining loops where multiple iterations of a loop are executed in parallel. The SPLOOP buffer reduces the code size associated with software pipelining. Furthermore, loops in the SPLOOP buffer are fully interruptible.
- **Compact Instructions** - The native instruction size for the C6000 devices is 32 bits. Many common instructions such as MPY, AND, OR, ADD, and SUB can be expressed as 16 bits if the C64x+ compiler can restrict the code to use certain registers in the register file. This compression is performed by the code generation tools.
- **Instruction Set Enhancement** - As noted above, there are new instructions such as 32-bit multiplications, complex multiplications, packing, sorting, bit manipulation, and 32-bit Galois field multiplication.
- **Exceptions Handling** - Intended to aid the programmer in isolating bugs. The C64x+ CPU is able to detect and respond to exceptions, both from internally detected sources (such as illegal op-codes) and from system events (such as a watchdog time expiration).
- **Privilege** - Defines user and supervisor modes of operation, allowing the operating system to give a basic level of protection to sensitive resources. Local memory is divided into multiple pages, each with read, write, and execute permissions.
- **Time-Stamp Counter** - Primarily targeted for Real-Time Operating System (RTOS) robustness, a free-running time-stamp counter is implemented in the CPU which is *not* sensitive to system stalls.

For more details on the C64x+ CPU and its enhancements over the C64x architecture, see the following documents:

- *TMS320C64x/C64x+ DSP CPU and Instruction Set Reference Guide* (literature number SPRU732)
- *TMS320C64x Technical Overview* (literature number SPRU395)

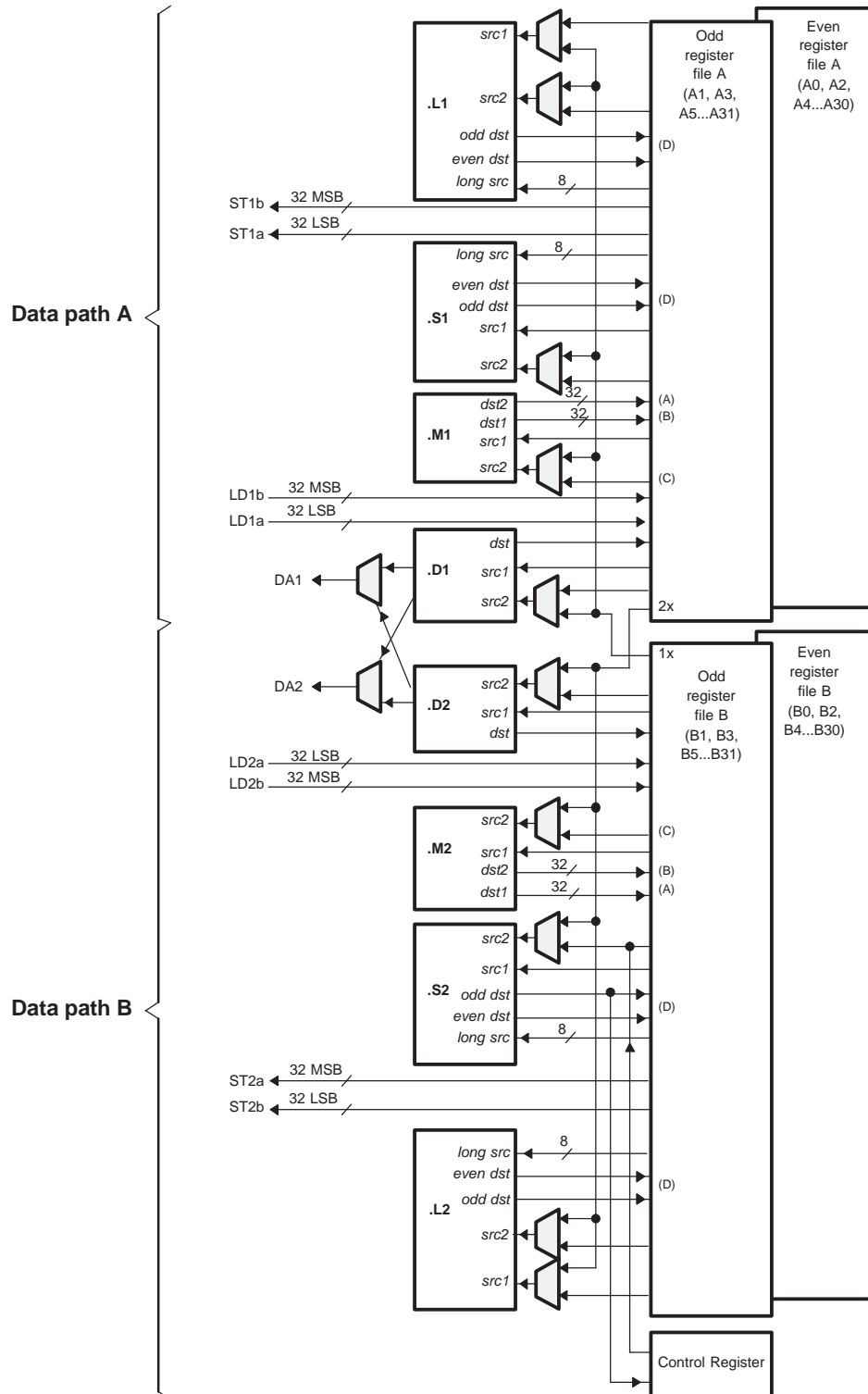

- A. On .M unit, *dst2* is 32 MSB.
- B. On .M unit, *dst1* is 32 LSB.
- C. On C64x CPU .M unit, *src2* is 32 bits; on C64x+ CPU .M unit, *src2* is 64 bits.
- D. On .L and .S units, *odd dst* connects to odd register files and *even dst* connects to even register files.

Figure 2-1. SM320C64x+™ CPU (DSP Core) Data Paths

## 2.4.2 DSP Memory Mapping

The DSP memory map is shown in [Section 2.5](#). Configuration of the control registers for DDR2, EMIFA, and ARM Internal RAM is supported by the ARM. The DSP has access to memories shown in the following sections.

### 2.4.2.1 ARM Internal Memories

The DSP has access to the 16KB ARM Internal RAM on the ARM D-TCM interface (i.e., data only).

### 2.4.2.2 External Memories

The DSP has access to the following External memories:

- DDR2 Synchronous DRAM
- Asynchronous EMIF / NOR Flash

### 2.4.2.3 DSP Internal Memories

The DSP has access to the following DSP memories:

- L2 RAM
- L1P RAM
- L1D RAM

### 2.4.2.4 C64x+ CPU

The C64x+ core uses a two-level cache-based architecture. The Level 1 Program cache (L1P) is 32 KB direct mapped cache and the Level 1 Data cache (L1D) is 80 KB 2-way set associated cache. The Level 2 memory/cache (L2) consists of a 64 KB memory space that is shared between program and data space. L2 memory can be configured as mapped memory, cache, or a combination of both.

[Table 2-2](#) shows a memory map of the C64x+ CPU cache registers for the device.

**Table 2-2. C64x+ Cache Registers**

HEX ADDRESS RANGE	REGISTER ACRONYM	DESCRIPTION
0x0184 0000	L2CFG	L2 Cache configuration register
0x0184 0020	L1PCFG	L1P Size Cache configuration register
0x0184 0024	L1PCC	L1P Freeze Mode Cache configuration register
0x0184 0040	L1DCFG	L1D Size Cache configuration register
0x0184 0044	L1DCC	L1D Freeze Mode Cache configuration register
0x0184 0048 - 0x0184 0FFC	-	Reserved
0x0184 1000	EDMAWEIGHT	L2 EDMA access control register
0x0184 1004 - 0x0184 1FFC	-	Reserved
0x0184 2000	L2ALLOC0	L2 allocation register 0
0x0184 2004	L2ALLOC1	L2 allocation register 1
0x0184 2008	L2ALLOC2	L2 allocation register 2
0x0184 200C	L2ALLOC3	L2 allocation register 3
0x0184 2010 - 0x0184 3FFF	-	Reserved
0x0184 4000	L2WBAR	L2 writeback base address register
0x0184 4004	L2WWC	L2 writeback word count register
0x0184 4010	L2WIBAR	L2 writeback invalidate base address register
0x0184 4014	L2WIWC	L2 writeback invalidate word count register
0x0184 4018	L2IBAR	L2 invalidate base address register
0x0184 401C	L2IWC	L2 invalidate word count register
0x0184 4020	L1PIBAR	L1P invalidate base address register
0x0184 4024	L1PIWC	L1P invalidate word count register
0x0184 4030	L1DWIBAR	L1D writeback invalidate base address register

**Table 2-2. C64x+ Cache Registers (continued)**

HEX ADDRESS RANGE	REGISTER ACRONYM	DESCRIPTION
0x0184 4034	L1DWIWC	L1D writeback invalidate word count register
0x0184 4038	-	Reserved
0x0184 4040	L1DWBAR	L1D Block Writeback
0x0184 4044	L1DWWC	L1D Block Writeback
0x0184 4048	L1DIBAR	L1D invalidate base address register
0x0184 404C	L1DIWC	L1D invalidate word count register
0x0184 4050 - 0x0184 4FFF	-	Reserved
0x0184 5000	L2WB	L2 writeback all register
0x0184 5004	L2WBINV	L2 writeback invalidate all register
0x0184 5008	L2INV	L2 Global Invalidate without writeback
0x0184 500C - 0x0184 5027	-	Reserved
0x0184 5028	L1PINV	L1P Global Invalidate
0x0184 502C - 0x0184 5039	-	Reserved
0x0184 5040	L1DWB	L1D Global Writeback
0x0184 5044	L1DWBINV	L1D Global Writeback with Invalidate
0x0184 5048	L1DINV	L1D Global Invalidate without writeback
0x0184 8000 - 0x0184 8004	MAR0 - MAR1	Reserved 0x0000 0000 - 0x01FF FFFF
0x0184 8008 - 0x0184 8024	MAR2 - MAR9	Memory Attribute Registers for EMIFA 0x0200 0000 - 0x09FF FFFF
0x0184 8028 - 0x0184 802C	MAR10 - MAR11	Reserved 0x0A00 0000 - 0x0BFF FFFF
0x0184 8030 - 0x0184 803C	MAR12 - MAR15	Memory Attribute Registers for VLYNQ 0x0C00 0000 - 0x0FFF FFFF
0x0184 8040 - 0x0184 8104	MAR16 - MAR65	Reserved 0x1000 0000 - 0x41FF FFFF
0x0184 8108 - 0x0184 813C	MAR66 - MAR79	Memory Attribute Registers for EMIFA/VLYNQ Shadow 0x4200 0000 - 0x4FFF FFFF
0x0184 8140 - 0x0184 81FC	MAR80 - MAR127	Reserved 0x5000 0000 - 0x7FFF FFFF
0x0184 8200 - 0x0184 823C	MAR128 - MAR143	Memory Attribute Registers for DDR2 0x8000 0000 - 0x8FFF FFFF
0x0184 8240 - 0x0184 83FC	MAR144 - MAR255	Reserved 0x9000 0000 - 0xFFFF FFFF

### 2.4.3 Peripherals

The DSP has controllability for the following peripherals:

- VICP
- EDMA
- ASP
- 2 Timers (Timer 0 and Timer1) that can each be configured as 1 64-bit or 2 32-bit timers

### 2.4.4 DSP Interrupt Controller

The DSP Interrupt Controller accepts device interrupts and appropriately maps them to the DSP's available interrupts. The DSP Interrupt Controller is briefly described in this document in the Interrupts section. For more detailed on the DSP Interrupt Controller, see the Documentation Support section of this document for the C64x+ CPU User's Guide.

## 2.5 Memory Map Summary

Table 2-3 shows the memory map address ranges of the device. Table 2-4 depicts the expanded map of the Configuration Space (0x0180 0000 through 0x0FFF FFFF). The device has multiple on-chip memories associated with its two processors and various subsystems. To help simplify software development a unified memory map is used where possible to maintain a consistent view of device resources across all bus masters.



**Table 2-3. Memory Map Summary**

START ADDRESS	END ADDRESS	SIZE (Bytes)	ARM	C64x+	EDMA/ PERIPHERAL	HPI	VPSS	
0x0000 0000	0x0000 1FFF	8K	ARM RAM0 (Instruction)	Reserved	Reserved	Reserved		
0x0000 2000	0x0000 3FFF	8K	ARM RAM1 (Instruction)					
0x0000 4000	0x0000 5FFF	8K	ARM ROM (Instruction)					
0x0000 6000	0x0000 7FFF	8K	Reserved					
0x0000 8000	0x0000 9FFF	8K	ARM RAM0 (Data)					
0x0000 A000	0x0000 BFFF	8K	ARM RAM1 (Data)					
0x0000 C000	0x0000 DFFF	8K	ARM ROM (Data)					
0x0000 E000	0x0000 FFFF	8K	Reserved	Reserved	Reserved			
0x0001 0000	0x000F FFFF	960K						
0x0010 0000	0x001F FFFF	1M					VICP	
0x0020 0000	0x007F FFFF	6M					Reserved	
0x0080 0000	0x0080 FFFF	64K					L2 RAM/Cache	
0x0081 0000	0x00E0 7FFF	6112K					Reserved	
0x00E0 8000	0x00E0 FFFF	32K					L1P Cache	
0x00E1 0000	0x00F0 3FFF	976K					Reserved	
0x00F0 4000	0x00F0 FFFF	48K					L1D RAM	
0x00F1 0000	0x00F1 7FFF	32K					L1D Cache	
0x00F1 8000	0x017F FFFF	9120K					Reserved	
0x0180 0000	0x01BB FFFF	3840K						
0x01BC 0000	0x01BC 0FFF	4K					ARM ETB Memory	CFG Space
0x01BC 1000	0x01BC 17FF	2K					ARM ETB Registers	
0x01BC 1800	0x01BC 18FF	256	ARM IceCrusher					
0x01BC 1900	0x01BF FFFF	255744	Reserved					
0x01C0 0000	0x01FF FFFF	4M	CFG Bus Peripherals	CFG Bus Peripherals	CFG Bus Peripherals	CFG Bus Peripherals <sup>(1)</sup>	Reserved	
0x0200 0000	0x09FF FFFF	128M	EMIFA (Code and Data)	EMIFA (Data)	EMIFA (Data)	Reserved		
0x0A00 0000	0x0BFF FFFF	32M	Reserved	Reserved	Reserved			
0x0C00 0000	0x0FFF FFFF	64M	VLYNQ (Remote)	Reserved	VLYNQ (Remote)			
0x1000 0000	0x1000 7FFF	32K	Reserved	Reserved	Reserved			
0x1000 8000	0x1000 9FFF	8K		ARM RAM0	ARM RAM0			
0x1000 A000	0x1000 BFFF	8K		ARM RAM1	ARM RAM1			
0x1000 C000	0x1000 DFFF	8K		ARM ROM	ARM ROM			
0x1000 E000	0x1000 FFFF	8K						
0x1001 0000	0x110F FFFF	17344K			Reserved			Reserved
0x1110 0000	0x111F FFFF	1M						
0x1120 0000	0x117F FFFF	6M						
0x1180 0000	0x1180 FFFF	64K	L2 RAM/Cache	L2 RAM/Cache	L2 RAM/Cache			
0x1181 0000	0x11E0 7FFF	6112K	Reserved	Reserved	Reserved			
0x11E0 8000	0x11E0 FFFF	32K	L1P Cache	L1P Cache	L1P Cache			
0x11E1 0000	0x11F0 3FFF	976K	Reserved	Reserved	Reserved			
0x11F0 4000	0x11F0 FFFF	48K	L1D RAM	L1D RAM	L1D RAM			
0x11F1 0000	0x11F1 7FFF	32K	L1D RAM/Cache	L1D RAM/Cache	L1D RAM/Cache			
0x11F1 8000	0x1FFF FFFF	241M-32K	Reserved	Reserved	Reserved			
0x2000 0000	0x2000 7FFF	32K	DDR2 Control Registers	DDR2 Control Registers	DDR2 Control Registers	DDR2 Control Registers		
0x2000 8000	0x41FF FFFF	544M-32k	Reserved	Reserved	Reserved	Reserved		
0x4200 0000 <sup>(2)</sup>	0x4FFF FFFF	224M	Reserved	EMIFA/VLYNQ Shadow	EMIFA/VLYNQ Shadow			
0x5000 0000	0x7FFF FFFF	768M	Reserved	Reserved	Reserved			
0x8000 0000	0x8FFF FFFF	256M	DDR2	DDR2	DDR2	DDR2	DDR2	
0x9000 0000	0xFFFF FFFF	1792M	Reserved	Reserved	Reserved	Reserved	Reserved	

(1) HPI's access to the configuration bus peripherals is limited to the power and sleep controller registers, PLL1 and PLL2 registers, and HPI configuration registers.

(2) EMIFA shadow memory started at 0x4200 0000 is physically the same memory as location 0x2000 0000. Memory range 0x2000 0000 through 0x09FF FFFF should only be used by C64x+ for data accesses. Memory range 0x4200 0000 through 0x4FFF FFFF can be used by C64x+ for both code execution and data accesses.

**Table 2-4. Configuration Memory Map Summary**

START ADDRESS	END ADDRESS	SIZE (Bytes)	ARM/EDMA	C64x+		
0x0180 0000	0x0180 FFFF	64K	Reserved	C64x+ Interrupt Controller		
0x0181 0000	0x0181 0FFF	4K		C64x+ Powerdown Controller		
0x0181 1000	0x0181 1FFF	4K		C64x+ Security ID		
0x0181 2000	0x0181 2FFF	4K		C64x+ Revision ID		
0x0182 0000	0x0182 FFFF	64K		C64x+ EMC		
0x0183 0000	0x0183 FFFF	64K		Reserved		
0x0184 0000	0x0184 FFFF	64K		C64x+ Memory System		
0x0185 0000	0x0187 FFFF	192K		Reserved		
0x0188 0000	0x01BB FFFF	3328K		Reserved		
0x01BC 0000	0x01BC 00FF	256		ARM ETB Memory	Reserved	
0x01BC 0100	0x01BC 01FF	256	Pin Manager and Trace			
0x01BC 0200	0x01BC 0FFF	3.5K	ARM ETB Registers		Reserved	
0x01BC 1000	0x01BC 17FF	2K				
0x01BC 1800	0x01BC 18FF	256				ARM Ice Crusher
0x01BC 1900	0x01BF FFFF	255744				Reserved
0x01C0 0000	0x01C0 FFFF	64K	EDMA CC		EDMA CC	
0x01C1 0000	0x01C1 03FF	1K	EDMA TC0	EDMA TC0		
0x01C1 0400	0x01C1 07FF	1K	EDMA TC1	EDMA TC1		
0x01C1 8800	0x01C1 9FFF	6K	Reserved	Reserved		
0x01C1 A000	0x01C1 FFFF	24K				
0x01C2 0000	0x01C2 03FF	1K			UART0	
0x01C2 0400	0x01C2 07FF	1K			UART1	
0x01C2 0800	0x01C2 0BFF	1K			UART2	
0x01C2 0C00	0x01C2 0FFF	1K			Reserved	
0x01C2 1000	0x01C2 13FF	1K			I2C	
0x01C2 1400	0x01C2 17FF	1K			Timer0	Timer0
0x01C2 1800	0x01C2 1BFF	1K			Timer1	Timer1
0x01C2 1C00	0x01C2 1FFF	1K			Timer2 (Watchdog)	Reserved
0x01C2 2000	0x01C2 23FF	1K	PWM0			
0x01C2 2400	0x01C2 27FF	1K	PWM1			
0x01C2 2800	0x01C2 2BFF	1K	PWM2			
0x01C2 2C00	0x01C3 FFFF	117K	Reserved			
0x01C4 0000	0x01C4 07FF	2K	System Module	System Module		
0x01C4 0800	0x01C4 0BFF	1K	PLL Controller 1	Reserved		
0x01C4 0C00	0x01C4 0FFF	1K	PLL Controller 2			
0x01C4 1000	0x01C4 1FFF	4K	Power and Sleep Controller	Power and Sleep Controller		
0x01C4 2000	0x01C4 202F	48	Reserved	Reserved		
0x01C4 2030	0x01C4 2033	4	DDR2 VTP Reg	DDR2 VTP Reg		

**Table 2-4. Configuration Memory Map Summary (continued)**

START ADDRESS	END ADDRESS	SIZE (Bytes)	ARM/EDMA	C64x+
0x01C4 2034	0x01C4 23FF	1K - 52	Reserved	Reserved
0x01C4 2400	0x01C4 7FFF	23K		
0x01C4 8000	0x01C4 83FF	1K	ARM Interrupt Controller	
0x01C4 8400	0x01C5 FFFF	95K	Reserved	
0x01C6 0000	0x01C6 3FFF	16K		
0x01C6 4000	0x01C6 5FFF	8K	USB2.0 Registers / RAM	
0x01C6 6000	0x01C6 67FF	2K	ATA/CF	
0x01C6 6800	0x01C6 6FFF	2K	SPI	
0x01C6 7000	0x01C6 77FF	2K	GPIO	
0x01C6 7800	0x01C6 7FFF	2K	HPI	
0x01C6 8000	0x01C6 FFFF	32K	Reserved	Reserved
0x01C7 0000	0x01C7 3FFF	16K	VPSS Registers	
0x01C7 4000	0x01C7 FFFF	48K	Reserved	
0x01C8 0000	0x01C8 0FFF	4K	EMAC Control Registers	
0x01C8 1000	0x01C8 1FFF	4K	EMAC Control Module Registers	
0x01C8 2000	0x01C8 3FFF	8K	EMAC Control Module RAM	
0x01C8 4000	0x01C8 47FF	2K	MDIO Control Registers	
0x01C8 4800	0x01C8 4FFF	2K	Reserved	
0x01C8 5000	0x01CB FFFF	236K		
0x01CC 0000	0x01CD FFFF	128K	VICP	
0x01CE 0000	0x01CF FFFF	128K	Reserved	Reserved
0x01D0 0000	0x01DF FFFF	1M		
0x01E0 0000	0x01E0 0FFF	4K	EMIFA Control	
0x01E0 1000	0x01E0 1FFF	4K	VLYNQ Control Registers	
0x01E0 2000	0x01E0 3FFF	8K	ASP	ASP
0x01E0 4000	0x01E0 FFFF	48K	Reserved	Reserved
0x01E1 0000	0x01E1 FFFF	64K	MMC/SD/SDIO	
0x01E2 0000	0x01E3 FFFF	128K	Reserved	
0x01E4 0000	0x01FF FFFF	1792K		
0x0200 0000	0x03FF FFFF	32M	EMIFA Data/Code (CS2)	EMIFA Data (CS2)
0x0400 0000	0x05FF FFFF	32M	EMIFA Data/Code (CS3)	EMIFA Data (CS3)
0x0600 0000	0x07FF FFFF	32M	EMIFA Data/Code (CS4)	EMIFA Data (CS4)
0x0800 0000	0x09FF FFFF	32M	EMIFA Data/Code (CS5)	EMIFA Data (CS5)
0x0A00 0000	0x0BFF FFFF	32M	Reserved	Reserved
0x0C00 0000	0x0FFF FFFF	64M	VLYNQ (Remote)	

## 2.6 Pin Assignments

Extensive use of pin multiplexing is used to accommodate the largest number of peripheral functions in the smallest possible package. Pin multiplexing is controlled using a combination of hardware configuration at device reset and software programmable register settings. For more information on pin muxing, see [Section 3.5.2, Multiplexed Pin Configurations](#), of this document.

### 2.6.1 Pin Map (Bottom View)

[Figure 2-2](#) through [Figure 2-5](#) show the bottom view of the package pin assignments in four quadrants (A, B, C, and D).

	1	2	3	4	5	6	7	8	9	10	
W	RSV3	DDR_D[4]	DDR_D[7]	DDR_D[9]	DDR_D[12]	DDR_D[14]	DDR_CLK0	$\overline{\text{DDR\_CLK0}}$	DDR_A[12]	DDR_A[11]	W
V	DDR_D[2]	DDR_D[3]	DDR_D[6]	DDR_D[8]	DDR_D[11]	DDR_D[13]	DDR_D[15]	DDR_CKE	DDR_BS[1]	DDR_A[8]	V
U	DDR_D[0]	DDR_D[1]	DDR_D[5]	DDR_DQS[0]	DDR_D[10]	DDR_DQS[1]	$\overline{\text{DDR\_RAS}}$	DDR_BS[0]	DDR_BS[2]	DDR_A[10]	U
T	$\overline{\text{EM\_CS5}}$ / GPIO8/ VLYNQ_ CLOCK	$\overline{\text{EM\_CS4}}$ / GPIO9/ VLYNQ_ SCRUN	EM_A[21]/ GPIO10/ VLYNQ_TXD0	DDR_ DQM[0]	DV <sub>DDR2</sub>	DDR_ DQM[1]	$\overline{\text{DDR\_CAS}}$	$\overline{\text{DDR\_WE}}$	$\overline{\text{DDR\_CS}}$	DDR_VDDLL	T
R	EM_A[12]/ GPIO19	EM_A[17]/ GPIO14/ VLYNQ_TXD2	EM_A[20]/ GPIO11/ VLYNQ_RXD0	EM_A[19]/ GPIO12/ VLYNQ_TXD1	EM_A[16]/ GPIO15/ VLYNQ_RXD2	V <sub>SS</sub>	V <sub>SS</sub>	RSV7	DV <sub>DDR2</sub>	V <sub>SS</sub>	R
P	EM_A[10]/ GPIO21	EM_A[11]/ GPIO20	EM_A[15]/ GPIO16/ VLYNQ_TXD3	EM_A[14]/ GPIO17/ VLYNQ_RXD3	EM_A[18]/ GPIO13/ VLYNQ_RXD1	DV <sub>DDR2</sub>	V <sub>SS</sub>	DV <sub>DDR2</sub>	V <sub>SS</sub>	DV <sub>DDR2</sub>	P
N	EM_A[6]/ GPIO25	EM_A[7]/ GPIO24	EM_A[8]/ GPIO23	EM_A[13]/ GPIO18	DV <sub>DD18</sub>	V <sub>SS</sub>	DV <sub>DDR2</sub>	V <sub>SS</sub>	DV <sub>DDR2</sub>	V <sub>SS</sub>	N
M	MXO	PLL <sub>VDD18</sub>	RSV24	EM_A[9]/ GPIO22	V <sub>SS</sub>	DV <sub>DD18</sub>	V <sub>SS</sub>	CV <sub>DD</sub>	V <sub>SS</sub>	CV <sub>DD</sub>	M
L	MXI/CLKIN	MX <sub>VSS</sub>	RSV6	$\overline{\text{RESET}}$	MX <sub>VDD</sub>	V <sub>SS</sub>	DV <sub>DD18</sub>	CV <sub>DD</sub>	CV <sub>DD</sub>	CV <sub>DD</sub>	L
K	CLK_OUT0/ GPIO48	EM_A[3]/ GPIO28	EM_A[5]/ GPIO26	EM_A[4]/ GPIO27	V <sub>SS</sub>	DV <sub>DD18</sub>	V <sub>SS</sub>	CV <sub>DDSP</sub>	CV <sub>DDSP</sub>	CV <sub>DD</sub>	K

**Figure 2-2. Pin Map [Quadrant A]**

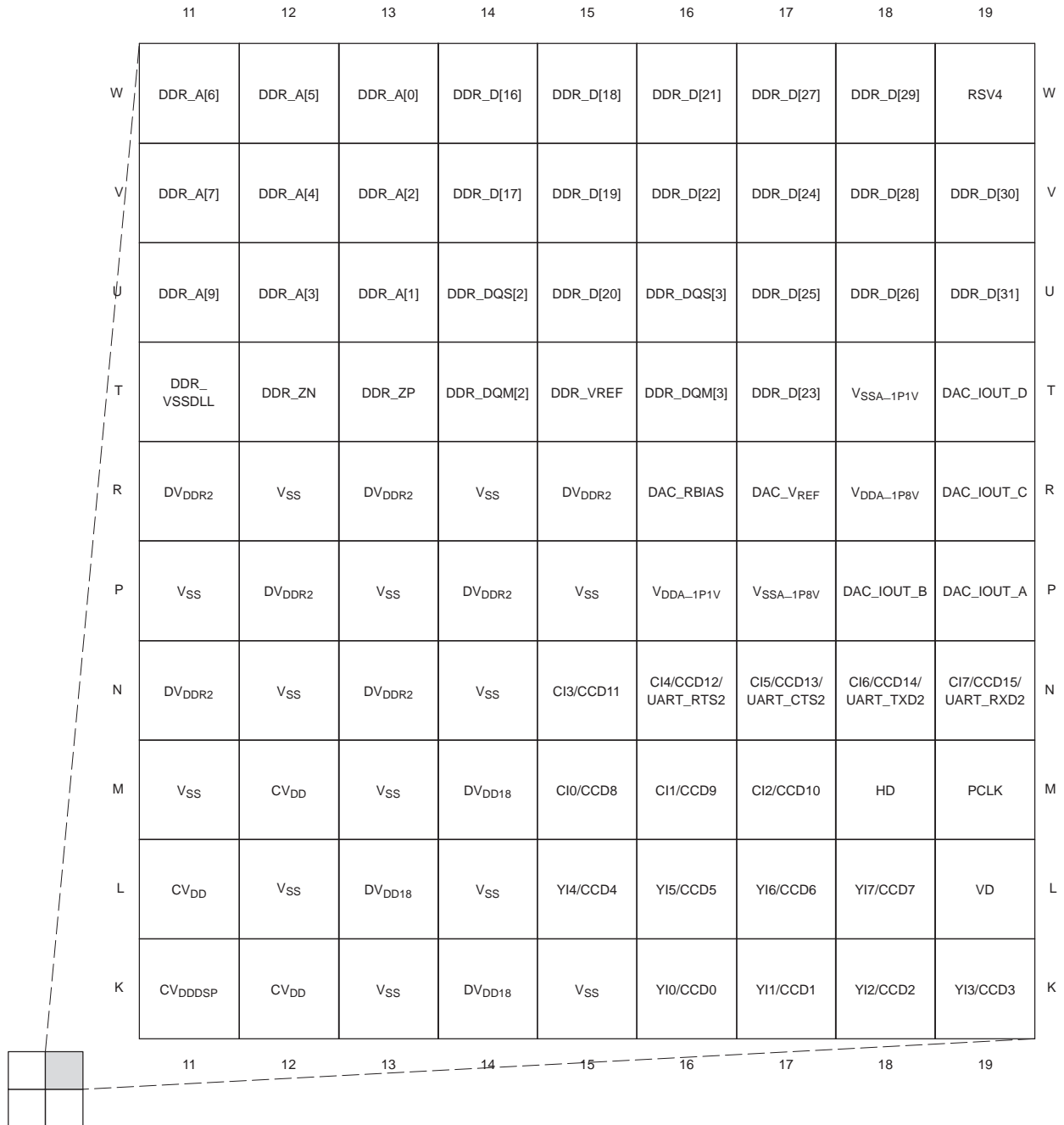

Figure 2-3. Pin Map [Quadrant B]

	11	12	13	14	15	16	17	18	19	
J	CVDDDSP	VSS	CVDDDSP	VSS	DVDD18	USB_ID	USB_VBUS	USB_VSSA3P3	USB_VDDA3P3	J
H	CVDDDSP	CVDDDSP	VSS	DVDD18	VSS	USB_VSS1P8	USB_VDD1P8	USB_R1	USB_DM	H
G	VSS	VSS	VSS	VSS	DVDD18	USB_VSSREF	USB_VSSA1P2LD0	USB_VDDA1P2LD0	USB_DP	G
F	DVDD33	DVDD33	DVDD33	DVDD18	CVDD	M24VDD	M24VSS	M24XI	M24XO	F
E	GPIOV33_10/ RXD3	GPIOV33_7/ RXD0	GPIOV33_0/ C_WE	GPIOV33_1/ G1	YOUT4/R4/ AEAW4	YOUT5/R5	YOUT6/R6	YOUT7/R7	CLK_OUT1/ TIM_IN/ GPIO49	E
D	GPIOV33_12/ RXDV	GPIOV33_4/ TXD1	GPIOV33_2/ G0	GPIOV33_3/ R1	YOUT0/G5/ AEAW0	YOUT1/G6/ AEAW1	YOUT2/G7/ AEAW2	YOUT3/R3/ AEAW3	VCLK	D
C	GPIOV33_8/ RXD1	GPIOV33_6/ TXD3	GPIOV33_1/ LCD_OE	GPIOV33_0/ LCD_FIELD	PWM0/ GPIO45	COUT7/G4	HSYNC	VSYNC	VPBECLK	C
B	GPIOV33_9/ RXD2	GPIOV33_3/ TXD0	GPIOV33_0/ TXEN	GPIOV33_1/ C_FIELD	PWM1/R2/ GPIO46	COUT1/B4/ BTSEL1	COUT3/B6/ DSP_BT	COUT5/G2	COUT6/G3	B
A	GPIOV33_5/ TXD2	GPIOV33_2/ COL	GPIOV33_1/ TXCLK	GPIOV33_0/ B1	PWM2/ B2/GPIO47	COUT0/B3/ BTSEL0	COUT2/B5/ EM_WIDTH	COUT4/B7	RSV2	A
	11	12	13	14	15	16	17	18	19	

Figure 2-4. Pin Map [Quadrant C]

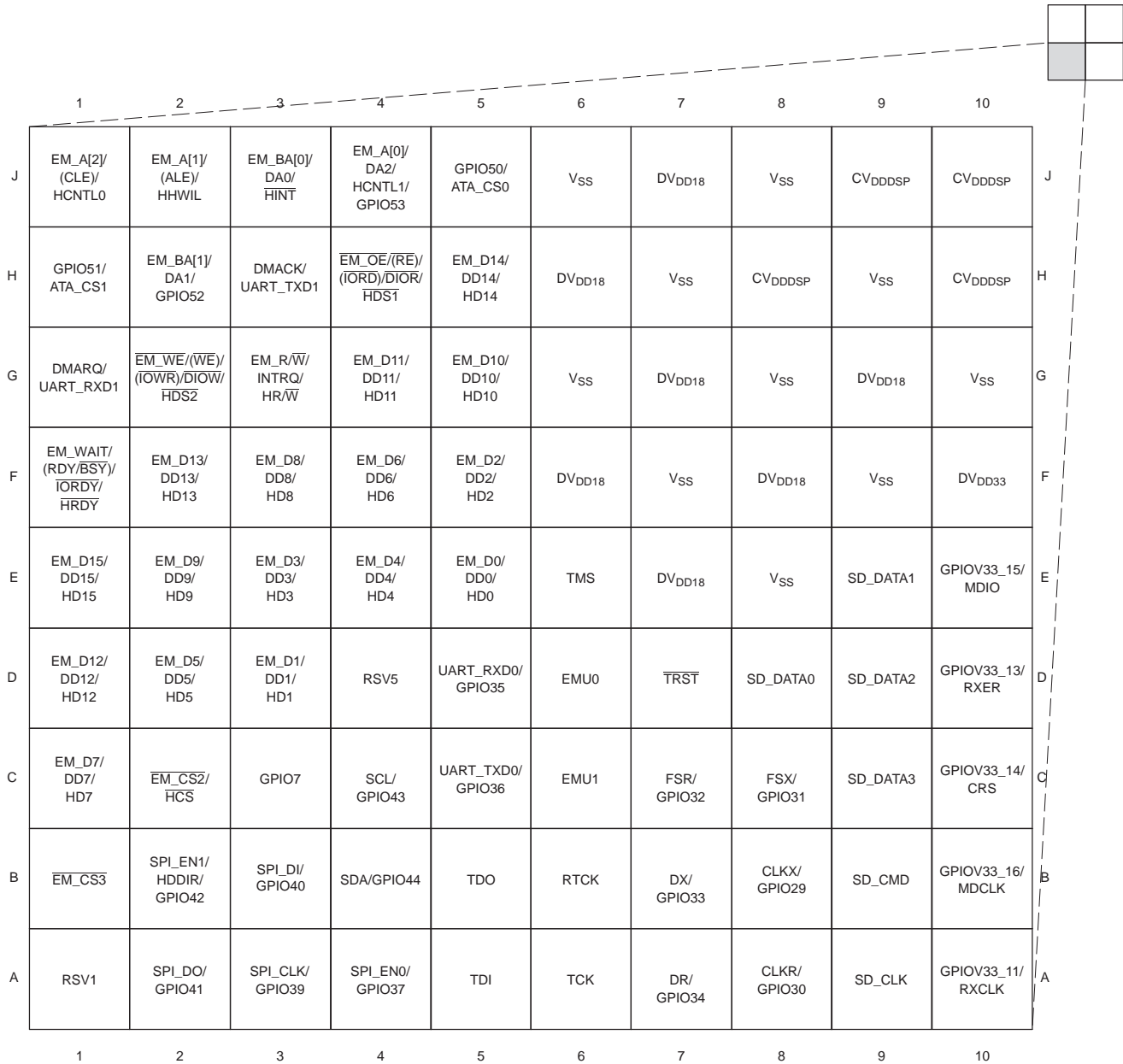

Figure 2-5. Pin Map [Quadrant D]

## 2.7 Terminal Functions

The terminal functions tables (Table 2-5 through Table 2-30) identify the external signal names, the associated pin (ball) numbers along with the mechanical package designator, the pin type, whether the pin has any internal pullup or pulldown resistors, and a functional pin description. For more detailed information on device configuration, peripheral selection, multiplexed/shared pin, and see the *Device Configurations* section of this data manual.

**Table 2-5. BOOT Terminal Functions**

SIGNAL		NO.	TYPE <sup>(1)</sup>	OTHER <sup>(2)(3)</sup>	DESCRIPTION	
NAME						
<b>BOOT</b>						
COOUT0/ B3/ BTSEL0	A16	I/O/Z	IPD DV <sub>DD18</sub>	These pins are multiplexed between ARM boot mode and the VPBE. At reset, the boot mode inputs BTSEL0 and BTSEL1 are sampled to determine the ARM boot configuration. See below for the boot modes set by these inputs. See the Bootmode section for more details. After reset, these are video encoder outputs COOUT0 and COOUT1, or RGB666/888 Blue output data bits 3 and 4 B3/B4.		
COOUT1/ B4/ BTSEL1	B16	I/O/Z	IPD DV <sub>DD18</sub>	<b>BTSEL1</b>	<b>BTSEL0</b>	<b>ARM Boot Mode</b>
				0	0	ARM ROM Boot (NAND) [default]
				0	1	ARM EMIFA Boot (NOR)
				1	0	ARM ROM Boot (HPI)
1	1	ARM ROM Boot (UART0)				
COOUT2/ B5/ EM_WIDTH	A17	I/O/Z	IPD DV <sub>DD18</sub>	This pin is multiplexed between EMIFA and the VPBE. At reset, the input state is sampled to set the EMIFA data bus width (EM_WIDTH). For an 8-bit wide EMIFA data bus, EM_WIDTH = 0. For a 16-bit wide EMIFA data bus, EM_WIDTH = 1. After reset, it is video encoder output COOUT2 or RGB666/888 Blue output data bit 5 B5.		
COOUT3/ B6/ DSP_BT	B17	I/O/Z	IPD DV <sub>DD18</sub>	This pin is multiplexed between DSP boot and the VPBE. At reset, the input state is sampled to set the DSP boot source DSP_BT. The DSP is booted by the ARM when DSP_BT=0. The DSP boots from EMIFA when DSP_BT=1. After reset, it is video encoder output COOUT3 or RGB666/888 Blue data bit 6 output B6.		
YOUT0/ G5/ AEAW0	D15	I/O/Z	IPD DV <sub>DD18</sub>	These pins are multiplexed between EMIFA and the VPBE. At reset, the input states of AEAW[4:0] are sampled to set the EMIFA address bus width. See the Peripheral Selection at Device Reset section for details. After reset, these are video encoder outputs YOUT[0:4] or RGB666/888 Red and Green data bit outputs G5, G6, G7, R3, and R4.		
YOUT1/ G6/ AEAW1	D16	I/O/Z	IPD DV <sub>DD18</sub>			
YOUT2/ G7/ AEAW2	D17	I/O/Z	IPD DV <sub>DD18</sub>			
YOUT3/ R3/ AEAW3	D18	I/O/Z	IPD DV <sub>DD18</sub>			
YOUT4/ R4/ AEAW4	E15	I/O/Z	IPD DV <sub>DD18</sub>			

- (1) I = Input, O = Output, Z = High impedance, S = Supply voltage, GND = Ground, A = Analog signal
- (2) IPD = Internal pulldown, IPU = Internal pullup. (To pull up a signal to the opposite supply rail, a 1-kΩ resistor should be used.)
- (3) Specifies the operating I/O supply voltage for each signal



**Table 2-6. Oscillator/PLL Terminal Functions**

SIGNAL NAME	NO.	TYPE <sup>(1)</sup>	OTHER <sup>(2)</sup>	DESCRIPTION
<b>OSCILLATOR, PLL</b>				
MXI/CLKIN	L1	I	DV <sub>DD18</sub>	Crystal input MXI for MX oscillator (system oscillator, typically 27 MHz). If a crystal input <i>is not</i> used, but instead a physical clock-in source is supplied, this is the external oscillator clock input.
MXO	M1	O	DV <sub>DD18</sub>	Crystal output for MX oscillator. If a crystal input <i>is not</i> used, but instead a physical clock-in source is supplied, MXO should be left as a No Connect.
MXV <sub>DD</sub>	L5	S	(3)	1.8-V power supply for MX oscillator. If a crystal input <i>is not</i> used, but instead a physical clock-in source is supplied, MXV <sub>DD</sub> should still be connected to the 1.8-V power supply.
MXV <sub>SS</sub>	L2	GND	(3)	Ground for MX oscillator. If a crystal input <i>is not</i> used, but instead a physical clock-in source is supplied, MXV <sub>SS</sub> should still be connected to ground.
M24XI	F18	I	DV <sub>DD18</sub>	Crystal input for M24 oscillator (24 MHz for USB). If a crystal input <i>is not</i> used, but instead a physical clock-in source is supplied, this is the external oscillator clock input. When the USB peripheral <i>is not</i> used, M24XI should be left as a No Connect.
M24XO	F19	O	DV <sub>DD18</sub>	Crystal output for M24 oscillator. If a crystal input <i>is not</i> used, but instead a physical clock-in source is supplied, M24XO should be left as a No Connect. When the USB peripheral <i>is not</i> used, M24XO should be left as a No Connect.
M24V <sub>DD</sub>	F16	S	(3)	1.8-V power supply for M24 oscillator. If a crystal input <i>is not</i> used, but instead a physical clock-in source is supplied, M24V <sub>DD</sub> should still be connected to the 1.8-V power supply. When the USB peripheral <i>is not</i> used, M24V <sub>DD</sub> should be connected to the 1.8-V power supply.
M24V <sub>SS</sub>	F17	GND	(3)	Ground for M24 oscillator. If a crystal input <i>is not</i> used, but instead a physical clock-in source is supplied, M24V <sub>SS</sub> should still be connected to ground. When the USB peripheral <i>is not</i> used, M24V <sub>SS</sub> should be connected to ground.
PLLV <sub>DD18</sub>	M2	S	(3)	1.8-V power supply for PLLs (system).

(1) I = Input, O = Output, Z = High impedance, S = Supply voltage, GND = Ground, A = Analog signal

(2) Specifies the operating I/O supply voltage for each signal

(3) For more information, see the *Recommended Operating Conditions* table**Table 2-7. Clock Generator Terminal Functions**

SIGNAL NAME	NO.	TYPE <sup>(1)</sup>	OTHER <sup>(2)</sup>	DESCRIPTION
<b>CLOCK GENERATOR</b>				
CLK_OUT0/ GPIO48	K1	I/O/Z	DV <sub>DD18</sub>	This pin is multiplexed between the PLL1 clock generator and GPIO. For the PLL1 clock generator, it is clock output CLK_OUT0. This is configurable for 13.5 MHz or 27 MHz clock outputs.
CLK_OUT1/ TIM_IN/ GPIO49	E19	I/O/Z	DV <sub>DD18</sub>	This pin is multiplexed between the USB clock generator, timer, and GPIO. For the USB clock generator, it is clock output CLK_OUT1. This is configurable for 12 MHz or 24 MHz clock outputs.

(1) I = Input, O = Output, Z = High impedance, S = Supply voltage, GND = Ground, A = Analog signal

(2) Specifies the operating I/O supply voltage for each signal

**Table 2-8. RESET and JTAG Terminal Functions**

SIGNAL NAME	NO.	TYPE <sup>(1)</sup>	OTHER <sup>(2)(3)</sup>	DESCRIPTION
<b>RESET</b>				
$\overline{\text{RESET}}$	L4	I	IPU DV <sub>DD18</sub>	This is the active low global reset input.
<b>JTAG</b>				
TMS	E6	I	IPU DV <sub>DD18</sub>	JTAG test-port mode select input

(1) I = Input, O = Output, Z = High impedance, S = Supply voltage, GND = Ground, A = Analog signal

(2) IPD = Internal pulldown, IPU = Internal pullup. (To pull up a signal to the opposite supply rail, a 1-k $\Omega$  resistor should be used.)

(3) Specifies the operating I/O supply voltage for each signal

**Table 2-8. RESET and JTAG Terminal Functions (continued)**

SIGNAL NAME	NO.	TYPE <sup>(1)</sup>	OTHER <sup>(2)(3)</sup>	DESCRIPTION
TDO	B5	O/Z	– DV <sub>DD18</sub>	JTAG test-port data output
TDI	A5	I	IPU DV <sub>DD18</sub>	JTAG test-port data input
TCK	A6	I	IPU DV <sub>DD18</sub>	JTAG test-port clock input
RTCK	B6	O/Z	– DV <sub>DD18</sub>	JTAG test-port return clock output
$\overline{\text{TRST}}$	D7	I	IPD DV <sub>DD18</sub>	JTAG test-port reset. For IEEE 1149.1 JTAG compatibility, see the IEEE 1149.1 JTAG compatibility statement portion of this data manual .
EMU1	C6	I/O/Z	IPU DV <sub>DD18</sub>	Emulation pin 1
EMU0	D6	I/O/Z	IPU DV <sub>DD18</sub>	Emulation pin 0

**Table 2-9. EMIFA Terminal Functions**

SIGNAL NAME	NO.	TYPE <sup>(1)</sup>	OTHER <sup>(2)(3)</sup>	DESCRIPTION
<b>EMIFA BOOT CONFIGURATION</b>				
COUT2/ B5/ EM_WIDTH	A17	I/O/Z	IPD DV <sub>DD18</sub>	This pin is multiplexed between EMIFA and the VPBE. At reset, the input state is sampled to set the EMIFA data bus width (EM_WIDTH). For an 8-bit wide EMIFA data bus, EM_WIDTH = 0. For a 16-bit wide EMIFA data bus, EM_WIDTH = 1. After reset, it is video encoder output COUT2 or RGB666/888 Blue output data bit 5 B5.
COUT3/ B6/ DSP_BT	B17	I/O/Z	IPD DV <sub>DD18</sub>	This pin is multiplexed between DSP boot and the VPBE. At reset, the input state is sampled to set the DSP boot source DSP_BT. The DSP is booted by the ARM when DSP_BT=0. The DSP boots from EMIFA when DSP_BT=1. After reset, it is video encoder output COUT3 or RGB666/888 Blue data bit 6 output B6.
YOUT0/ G5/ AEAW0	D15	I/O/Z	IPD DV <sub>DD18</sub>	These pins are multiplexed between EMIFA and the VPBE. At reset, the input states of AEAW[4:0] are sampled to set the EMIFA address bus width. See the Peripheral Selection at Device Reset section for details. After reset, these are video encoder outputs YOUT[0:4] or RGB666/888 Red and Green data bit outputs G5, G6, G7, R3, and R4.
YOUT1/ G6/ AEAW1	D16	I/O/Z	IPD DV <sub>DD18</sub>	
YOUT2/ G7/ AEAW2	D17	I/O/Z	IPD DV <sub>DD18</sub>	
YOUT3/ R3/ AEAW3	D18	I/O/Z	IPD DV <sub>DD18</sub>	
YOUT4/ R4/ AEAW4	E15	I/O/Z	IPD DV <sub>DD18</sub>	
<b>EMIFA FUNCTIONAL PINS: ASYNC / NOR</b>				
$\overline{\text{EM\_CS2}}$ / HCS	C2	I/O/Z	DV <sub>DD18</sub>	This pin is multiplexed between EMIFA and HPI. For EMIFA, this pin is Chip Select 2 output $\overline{\text{EM\_CS2}}$ for use with asynchronous memories (i.e., NOR flash) or NAND flash. This is the chip select for the default boot and ROM boot modes.
$\overline{\text{EM\_CS3}}$	B1	I/O/Z	DV <sub>DD18</sub>	For EMIFA, this pin is Chip Select 3 output $\overline{\text{EM\_CS3}}$ for use with asynchronous memories (i.e., NOR flash) or NAND flash.

(1) I = Input, O = Output, Z = High impedance, S = Supply voltage, GND = Ground, A = Analog signal

(2) IPD = Internal pulldown, IPU = Internal pullup. (To pull up a signal to the opposite supply rail, a 1-kΩ resistor should be used.)

(3) Specifies the operating I/O supply voltage for each signal

**Table 2-9. EMIFA Terminal Functions (continued)**

SIGNAL NAME	NO.	TYPE <sup>(1)</sup>	OTHER <sup>(2)(3)</sup>	DESCRIPTION
EM_CS4/ GPIO9/ VLYNQ_SCRUN	T2	I/O/Z	DV <sub>DD18</sub>	This pin is multiplexed between EMIFA, GPIO, and VLYNQ. For EMIFA, it is Chip Select 4 output EM_CS4 for use with asynchronous memories (i.e., NOR flash) or NAND flash.
EM_CS5/ GPIO8/ VLYNQ_CLOCK	T1	I/O/Z	DV <sub>DD18</sub>	This pin is multiplexed between EMIFA, GPIO, and VLYNQ. For EMIFA, it is Chip Select 5 output EM_CS5 for use with asynchronous memories (i.e., NOR flash) or NAND flash.
EM_R $\bar{W}$ / INTRQ/ HR $\bar{W}$	G3	I/O/Z	DV <sub>DD18</sub>	This pin is multiplexed between EMIFA, ATA/CF, and HPI. For EMIFA, it is read/write output EM_R $\bar{W}$ .
EM_WAIT/ (RDY/BSY)/ IORDY/ HRDY	F1	I/O/Z	IPU DV <sub>DD18</sub>	This pin is multiplexed between EMIFA (NAND/SmartMedia/xD), ATA/CF, and HPI. For EMIFA, it is wait state extension input EM_WAIT.
EM_OE/ (RE)/ (IORD)/ DIOR/ HDS1	H4	I/O/Z	DV <sub>DD18</sub>	This pin is multiplexed between EMIFA (NAND/SmartMedia/xD), ATA/CF, and HPI. For EMIFA, it is output enable output EM_OE.
EM_WE (WE) (IOWR)/ DIOW/ HDS2	G2	I/O/Z	DV <sub>DD18</sub>	This pin is multiplexed between EMIFA (NAND/SmartMedia/xD), ATA/CF, and HPI. For NAND/SmartMedia/xD or EMIFA, it is write enable output EM_WE.
EM_BA[0]/ DA0/ HINT	J3	I/O/Z	IPD DV <sub>DD18</sub>	This pin is multiplexed between EMIFA, ATA/CF, and HPI. For EMIFA, this is the Bank Address 0 output (EM_BA[0]). When connected to an 8-bit asynchronous memory, this pin is the lowest order bit of the byte address. When connected to a 16-bit asynchronous memory, this pin has the same function as EMIF address pin 22 (EM_A[22]).
EM_BA[1]/ DA1/ GPIO52	H2	I/O/Z	DV <sub>DD18</sub>	This pin is multiplexed between EMIFA, ATA/CF, and GPIO. For EMIFA, this is the Bank Address 1 output EM_BA[1]. When connected to a 16-bit asynchronous memory this pin is the lowest order bit of the 16-bit word address. When connected to an 8-bit asynchronous memory, this pin is the 2nd bit of the address.
EM_A[21]/ GPIO10/ VLYNQ_TXD0	T3	I/O/Z	DV <sub>DD18</sub>	This pin is multiplexed between EMIFA, GPIO, and VLYNQ. For EMIFA, it is address bit 21 output EM_A[21].
EM_A[20]/ GPIO11/ VLYNQ_RXD0	R3	I/O/Z	DV <sub>DD18</sub>	This pin is multiplexed between EMIFA, GPIO, and VLYNQ. For EMIFA, it is address bit 20 output EM_A[20].
EM_A[19]/ GPIO12/ VLYNQ_TXD1	R4	I/O/Z	DV <sub>DD18</sub>	This pin is multiplexed between EMIFA, GPIO, and VLYNQ. For EMIFA, it is address bit 19 output EM_A[19].
EM_A[18]/ GPIO13/ VLYNQ_RXD1	P5	I/O/Z	DV <sub>DD18</sub>	This pin is multiplexed between EMIFA, GPIO, and VLYNQ. For EMIFA, it is address bit 18 output EM_A[18].
EM_A[17]/ GPIO14/ VLYNQ_TXD2	R2	I/O/Z	DV <sub>DD18</sub>	This pin is multiplexed between EMIFA, GPIO, and VLYNQ. For EMIFA, it is address bit 17 output EM_A[17].
EM_A[16]/ GPIO15/ VLYNQ_RXD2	R5	I/O/Z	DV <sub>DD18</sub>	This pin is multiplexed between EMIFA, GPIO, and VLYNQ. For EMIFA, it is address bit 16 output EM_A[16].
EM_A[15]/ GPIO16/ VLYNQ_TXD3	P3	I/O/Z	DV <sub>DD18</sub>	This pin is multiplexed between EMIFA, GPIO, and VLYNQ. For EMIFA, it is address bit 15 output EM_A[15].
EM_A[14]/ GPIO17/ VLYNQ_RXD3	P4	I/O/Z	DV <sub>DD18</sub>	This pin is multiplexed between EMIFA, GPIO, and VLYNQ. For EMIFA, it is address bit 14 output EM_A[14].

**Table 2-9. EMIFA Terminal Functions (continued)**

SIGNAL NAME		NO.	TYPE <sup>(1)</sup>	OTHER <sup>(2)(3)</sup>	DESCRIPTION
EM_A[13]/ GPIO18		N4	I/O/Z	DV <sub>DD18</sub>	This pin is multiplexed between EMIFA and GPIO. For EMIFA, it is address bit 13 output EM_A[13].
EM_A[12]/ GPIO19		R1	I/O/Z	DV <sub>DD18</sub>	This pin is multiplexed between EMIFA and GPIO. For EMIFA, it is address bit 12 output EM_A[12].
EM_A[11]/ GPIO20		P2	I/O/Z	DV <sub>DD18</sub>	This pin is multiplexed between EMIFA and GPIO. For EMIFA, it is address bit 11 output EM_A[11].
EM_A[10]/ GPIO21		P1	I/O/Z	DV <sub>DD18</sub>	This pin is multiplexed between EMIFA and GPIO. For EMIFA, it is address bit 10 output EM_A[10].
EM_A[9]/ GPIO22		M4	I/O/Z	DV <sub>DD18</sub>	This pin is multiplexed between EMIFA and GPIO. For EMIFA, it is address bit 9 output EM_A[9].
EM_A[8]/ GPIO23		N3	I/O/Z	DV <sub>DD18</sub>	This pin is multiplexed between EMIFA and GPIO. For EMIFA, it is address bit 8 output EM_A[8].
EM_A[7]/ GPIO24		N2	I/O/Z	DV <sub>DD18</sub>	This pin is multiplexed between EMIFA and GPIO. For EMIFA, it is address bit 7 output EM_A[7].
EM_A[6]/ GPIO25		N1	I/O/Z	DV <sub>DD18</sub>	This pin is multiplexed between EMIFA and GPIO. For EMIFA, it is address bit 6 output EM_A[6].
EM_A[5]/ GPIO26		K3	I/O/Z	DV <sub>DD18</sub>	This pin is multiplexed between EMIFA and GPIO. For EMIFA, it is address bit 5 output EM_A[5].
EM_A[4]/ GPIO27		K4	I/O/Z	DV <sub>DD18</sub>	This pin is multiplexed between EMIFA and GPIO. For EMIFA, it is address bit 4 output EM_A[4].
EM_A[3]/ GPIO28		K2	I/O/Z	DV <sub>DD18</sub>	This pin is multiplexed between EMIFA and GPIO. For EMIFA, it is address bit 3 output EM_A[3].
EM_A[2]/ (CLE)/ HCNTL0		J1	I/O/Z	DV <sub>DD18</sub>	This pin is multiplexed between EMIFA and HPI. For EMIFA, this pin is the EM_A[2] address line.
EM_A[1]/ (ALE)/ HHWIL		J2	I/O/Z	DV <sub>DD18</sub>	This pin is multiplexed between EMIFA (NAND/SmartMedia.xD) and HPI.
EM_A[0]/ DA2/ HCNTL1/ GPIO53		J4	I/O/Z	DV <sub>DD18</sub>	This pin is multiplexed between EMIFA, ATA/CF, HPI, and GPIO. For EMIFA, this is Address output EM_A[0], which is the least significant bit on a 32-bit word address. When connected to a 16-bit asynchronous memory, this pin is the 2nd bit of the address. For an 8-bit asynchronous memory, this pin is the 3rd bit of the address.

**Table 2-9. EMIFA Terminal Functions (continued)**

SIGNAL		TYPE <sup>(1)</sup>	OTHER <sup>(2)(3)</sup>	DESCRIPTION
NAME	NO.			
EM_D0/ DD0/ HD0	E5	I/O/Z	DV <sub>DD18</sub>	<p>These pins are multiplexed between EMIFA (NAND), ATA/CF, and HPI. In all cases they are used as a 16 bit bi-directional data bus. For EMIFA (NAND), these are EM_D[15:0].</p>
EM_D1/ DD1/ HD1	D3	I/O/Z	DV <sub>DD18</sub>	
EM_D2/ DD2/ HD2	F5	I/O/Z	DV <sub>DD18</sub>	
EM_D3/ DD3/ HD3	E3	I/O/Z	DV <sub>DD18</sub>	
EM_D4/ DD4/ HD4	E4	I/O/Z	DV <sub>DD18</sub>	
EM_D5/ DD5/ HD5	D2	I/O/Z	DV <sub>DD18</sub>	
EM_D6/ DD6/ HD6	F4	I/O/Z	DV <sub>DD18</sub>	
EM_D7/ DD7/ HD7	C1	I/O/Z	DV <sub>DD18</sub>	
EM_D8/ DD8/ HD8	F3	I/O/Z	DV <sub>DD18</sub>	
EM_D9/ DD9/ HD9	E2	I/O/Z	DV <sub>DD18</sub>	
EM_D10/ DD10/ HD10	G5	I/O/Z	DV <sub>DD18</sub>	
EM_D11/ DD11/ HD11	G4	I/O/Z	DV <sub>DD18</sub>	
EM_D12/ DD12/ HD12	D1	I/O/Z	DV <sub>DD18</sub>	
EM_D13/ DD13/ HD13	F2	I/O/Z	DV <sub>DD18</sub>	
EM_D14/ DD14/ HD14	H5	I/O/Z	DV <sub>DD18</sub>	
EM_D15/ DD15/ HD15	E1	I/O/Z	DV <sub>DD18</sub>	

**Table 2-9. EMIFA Terminal Functions (continued)**

SIGNAL NAME	NO.	TYPE <sup>(1)</sup>	OTHER <sup>(2)(3)</sup>	DESCRIPTION
<b>EMIFA FUNCTIONAL PINS: NAND / SMARTMEDIA / xD</b>				
EM_A[1] (ALE)/ HHWIL	J2	I/O/Z	DV <sub>DD18</sub>	This pin is multiplexed between EMIFA and HPI. For NAND/SmartMedia/xD, it is Address Latch Enable output (ALE).
EM_A[2] (CLE)/ HCNTL0	J1	I/O/Z	DV <sub>DD18</sub>	This pin is multiplexed between EMIFA and HPI. For NAND/SmartMedia/xD, this pin is the Command Latch Enable output (CLE).
EM_WAIT/ (RDY/BSY)/ IORDY/ HRDY	F1	I/O/Z	IPU DV <sub>DD18</sub>	This pin is multiplexed between EMIFA (NAND/SmartMedia/xD), ATA/CF, and HPI. For NAND/SmartMedia/xD, it is ready/busy input (RDY/BSY).
$\overline{\text{EM\_OE}}$ / ( $\overline{\text{RE}}$ )/ ( $\overline{\text{IORD}}$ )/ DIOR/ HDS1	H4	I/O/Z	DV <sub>DD18</sub>	This pin is multiplexed between EMIFA (NAND/SmartMedia/xD), ATA/CF, and HPI. For NAND/SmartMedia/xD, it is read enable output ( $\overline{\text{RE}}$ ).
$\overline{\text{EM\_WE}}$ / ( $\overline{\text{WE}}$ )/ ( $\overline{\text{IOWR}}$ )/ DIOW/ HDS2	G2	I/O/Z	DV <sub>DD18</sub>	This pin is multiplexed between EMIFA (NAND/SmartMedia/xD), ATA/CF, and HPI. For NAND/SmartMedia/xD, it is write enable output ( $\overline{\text{WE}}$ ).
$\overline{\text{EM\_CS2}}$ / HCS	C2	I/O/Z	DV <sub>DD18</sub>	This pin is multiplexed between EMIFA and HPI. For EMIFA, this pin is Chip Select 2 output $\overline{\text{EM\_CS2}}$ for use with asynchronous memories (i.e. NOR flash) or NAND flash. This is the chip select for the default boot and ROM boot modes.
$\overline{\text{EM\_CS3}}$	B1	I/O/Z	DV <sub>DD18</sub>	For EMIFA, this pin is Chip Select 3 output $\overline{\text{EM\_CS3}}$ for use with asynchronous memories (i.e. NOR flash) or NAND flash.
EM_CS4/ GPIO9/ VLYNQ_SCRUN	T2	I/O/Z	DV <sub>DD18</sub>	This pin is multiplexed between EMIFA, GPIO, and VLYNQ. For EMIFA, it is Chip Select 4 output $\overline{\text{EM\_CS4}}$ for use with asynchronous memories (i.e., NOR flash) or NAND flash.
EM_CS5/ GPIO8/ VLYNQ_CLOCK	T1	I/O/Z	DV <sub>DD18</sub>	This pin is multiplexed between EMIFA, GPIO, and VLYNQ. For EMIFA, it is Chip Select 5 output $\overline{\text{EM\_CS5}}$ for use with asynchronous memories (i.e., NOR flash) or NAND flash.

**Table 2-9. EMIFA Terminal Functions (continued)**

SIGNAL NAME NO.		TYPE <sup>(1)</sup>	OTHER <sup>(2)(3)</sup>	DESCRIPTION
EM_D0/ DD0/ HD0	E5	I/O/Z	DV <sub>DD18</sub>	<p>These pins are multiplexed between EMIFA (NAND), ATA/CF, and HPI. In all cases they are used as a 16 bit bi-directional data bus. For EMIFA (NAND), these are EM_D[15:0].</p>
EM_D1/ DD1/ HD1	D3	I/O/Z	DV <sub>DD18</sub>	
EM_D2/ DD2/ HD2	F5	I/O/Z	DV <sub>DD18</sub>	
EM_D3/ DD3/ HD3	E3	I/O/Z	DV <sub>DD18</sub>	
EM_D4/ DD4/ HD4	E4	I/O/Z	DV <sub>DD18</sub>	
EM_D5/ DD5/ HD5	D2	I/O/Z	DV <sub>DD18</sub>	
EM_D6/ DD6/ HD6	F4	I/O/Z	DV <sub>DD18</sub>	
EM_D7/ DD7/ HD7	C1	I/O/Z	DV <sub>DD18</sub>	
EM_D8/ DD8/ HD8	F3	I/O/Z	DV <sub>DD18</sub>	
EM_D9/ DD9/ HD9	E2	I/O/Z	DV <sub>DD18</sub>	
EM_D10/ DD10/ HD10	G5	I/O/Z	DV <sub>DD18</sub>	
EM_D11/ DD11/ HD11	G4	I/O/Z	DV <sub>DD18</sub>	
EM_D12/ DD12/ HD12	D1	I/O/Z	DV <sub>DD18</sub>	
EM_D13/ DD13/ HD13	F2	I/O/Z	DV <sub>DD18</sub>	
EM_D14/ DD14/ HD14	H5	I/O/Z	DV <sub>DD18</sub>	
EM_D15/ DD15/ HD15	E1	I/O/Z	DV <sub>DD18</sub>	

**Table 2-10. DDR2 Memory Controller Terminal Functions**

SIGNAL NAME	NO.	TYPE <sup>(1)</sup>	OTHER <sup>(2)(3)</sup>	DESCRIPTION
<b>DDR2 Memory Controller</b>				
DDR_CLK0	W7	I/O/Z	DV <sub>DDR2</sub>	DDR2 Clock
$\overline{\text{DDR\_CLK0}}$	W8	I/O/Z	DV <sub>DDR2</sub>	DDR2 Differential clock
DDR_CKE	V8	I/O/Z	DV <sub>DDR2</sub>	DDR2 Clock Enable
$\overline{\text{DDR\_CS}}$	T9	I/O/Z	DV <sub>DDR2</sub>	DDR2 Active low chip select
$\overline{\text{DDR\_WE}}$	T8	I/O/Z	DV <sub>DDR2</sub>	DDR2 Active low Write enable
DDR_DQM[3]	T16	I/O/Z	DV <sub>DDR2</sub>	DDR2 Data mask outputs DQM3: For upper byte data bus DDR_D[31:24] DQM2: For DDR_D[23:16] DQM1: For DDR_D[15:8] DQM0: For lower byte DDR_D[7:0]
DDR_DQM[2]	T14	I/O/Z	DV <sub>DDR2</sub>	
DDR_DQM[1]	T6	I/O/Z	DV <sub>DDR2</sub>	
DDR_DQM[0]	T4	I/O/Z	DV <sub>DDR2</sub>	
$\overline{\text{DDR\_RAS}}$	U7	I/O/Z	DV <sub>DDR2</sub>	DDR2 Row Access Signal output
$\overline{\text{DDR\_CAS}}$	T7	I/O/Z	DV <sub>DDR2</sub>	DDR2 Column Access Signal output
DDR_DQS[0]	U4	I/O/Z	DV <sub>DDR2</sub>	Data strobe input/outputs for each byte of the 32-bit data bus. They are outputs to the DDR2 memory when writing and inputs when reading. They are used to synchronize the data transfers. DQS3 : For upper byte DDR_D[31:24] DQS2: For DDR_D[23:16] DQS1: For DDR_D[15:8] DQS0: For bottom byte DDR_D[7:0]
DDR_DQS[1]	U6	I/O/Z	DV <sub>DDR2</sub>	
DDR_DQS[2]	U14	I/O/Z	DV <sub>DDR2</sub>	
DDR_DQS[3]	U16	I/O/Z	DV <sub>DDR2</sub>	
DDR_BS[0]	U8	I/O/Z	DV <sub>DDR2</sub>	Bank select outputs (BS[2:0]). Two are required to support 1Gb DDR2 memories.
DDR_BS[1]	V9			
DDR_BS[2]	U9			
DDR_A[12]	W9	I/O/Z	DV <sub>DDR2</sub>	DDR2 address bus
DDR_A[11]	W10			
DDR_A[10]	U10			
DDR_A[9]	U11			
DDR_A[8]	V10			
DDR_A[7]	V11			
DDR_A[6]	W11			
DDR_A[5]	W12			
DDR_A[4]	V12			
DDR_A[3]	U12			
DDR_A[2]	V13			
DDR_A[1]	U13			
DDR_A[0]	W13			

- (1) I = Input, O = Output, Z = High impedance, S = Supply voltage, GND = Ground, A = Analog signal
- (2) Specifies the operating I/O supply voltage for each signal
- (3) For more information, see the *Recommended Operating Conditions* table



**Table 2-10. DDR2 Memory Controller Terminal Functions (continued)**

SIGNAL NAME		NO.	TYPE <sup>(1)</sup>	OTHER <sup>(2)(3)</sup>	DESCRIPTION
DDR_D[31]		U19	I/O/Z	DV <sub>DDR2</sub>	DDR2 data bus can be configured as 32 bits wide or 16 bits wide.
DDR_D[30]		V19			
DDR_D[29]		W18			
DDR_D[28]		V18			
DDR_D[27]		W17			
DDR_D[26]		U18			
DDR_D[25]		U17			
DDR_D[24]		V17			
DDR_D[23]		T17			
DDR_D[22]		V16			
DDR_D[21]		W16			
DDR_D[20]		U15			
DDR_D[19]		V15			
DDR_D[18]		W15			
DDR_D[17]		V14			
DDR_D[16]		W14			
DDR_D[15]		V7			
DDR_D[14]		W6			
DDR_D[13]		V6			
DDR_D[12]		W5			
DDR_D[11]		V5			
DDR_D[10]		U5			
DDR_D[9]		W4			
DDR_D[8]		V4			
DDR_D[7]		W3			
DDR_D[6]		V3			
DDR_D[5]		U3			
DDR_D[4]		W2			
DDR_D[3]		V2			
DDR_D[2]		V1			
DDR_D[1]		U2			
DDR_D[0]		U1			
DDR_VREF		T15	I	<sup>(3)</sup>	Reference voltage input for the SSTL_18 IO buffers.
DDR_VSSDLL		T11	GND	<sup>(3)</sup>	Ground for the DDR2 Digital Locked Loop.
DDR_VDDDLL		T10	S	<sup>(3)</sup>	Power (1.8 Volts) for the DDR2 Digital Locked Loop.
DDR_ZN		T12	O/Z	<sup>(3)</sup>	Impedance control for DDR2 outputs. This must be connected via a 200 Ω resistor to DV <sub>DDR2</sub> .
DDR_ZP		T13	O/Z	<sup>(3)</sup>	Impedance control for DDR2 outputs. This must be connected via a 200 Ω resistor to V <sub>SS</sub> .

**Table 2-11. I2C Terminal Functions**

SIGNAL NAME	NO.	TYPE <sup>(1)</sup>	OTHER <sup>(2)</sup>	DESCRIPTION
<b>I2C</b>				
SCL/ GPIO43	C4	I/O/Z	DV <sub>DD18</sub>	This pin is multiplexed between I2C and GPIO. For I2C, it is clock output SCL.
SDA/ GPIO44	B4	I/O/Z	DV <sub>DD18</sub>	This pin is multiplexed between I2C and GPIO. For I2C, it is bi-directional data signal SDA.

- (1) I = Input, O = Output, Z = High impedance, S = Supply voltage, GND = Ground, A = Analog signal  
(2) Specifies the operating I/O supply voltage for each signal

**Table 2-12. Audio Serial Port (ASP) Terminal Functions**

SIGNAL NAME	NO.	TYPE <sup>(1)</sup>	OTHER <sup>(2)</sup>	DESCRIPTION
<b>Audio Serial Port (ASP)</b>				
CLKX/ GPIO29	B8	I/O/Z	DV <sub>DD18</sub>	This pin is multiplexed between ASP and GPIO. For ASP, it is Transmit clock IO CLKX.
CLKR/ GPIO30	A8	I/O/Z	DV <sub>DD18</sub>	This pin is multiplexed between ASP and GPIO. For ASP, it is Receive clock IO CLKR.
FSX/ GPIO31	C8	I/O/Z	DV <sub>DD18</sub>	This pin is multiplexed between ASP and GPIO. For ASP, it is Transmit frame synchronization IO FSX.
FSR/ GPIO32	C7	I/O/Z	DV <sub>DD18</sub>	This pin is multiplexed between ASP and GPIO. For ASP, it is Receive frame synchronization IO FSR.
DX/ GPIO33	B7	I/O/Z	DV <sub>DD18</sub>	This pin is multiplexed between ASP and GPIO. For ASP, it is Data Transmit output DX.
DR/ GPIO34	A7	I/O/Z	DV <sub>DD18</sub>	This pin is multiplexed between ASP and GPIO. For ASP, it is Data Receive input DR.

- (1) I = Input, O = Output, Z = High impedance, S = Supply voltage, GND = Ground, A = Analog signal  
(2) Specifies the operating I/O supply voltage for each signal

**Table 2-13. SPI Terminal Functions**

SIGNAL NAME	NO.	TYPE <sup>(1)</sup>	OTHER <sup>(2)</sup>	DESCRIPTION
<b>Serial Peripheral Interface (SPI)</b>				
SPI_EN0/ GPIO37	A4	I/O/Z	DV <sub>DD18</sub>	This pin is multiplexed between SPI and GPIO. When used by SPI, it is SPI slave device 0 enable output SPI_EN0.
SPI_EN1/ HDDIR/ GPIO42	B2	I/O/Z	DV <sub>DD18</sub>	This pin is multiplexed between SPI, ATA, and GPIO. When used by SPI, it is SPI slave device 1 enable output SPI_EN1.
SPI_CLK/ GPIO39	A3	I/O/Z	DV <sub>DD18</sub>	This pin is multiplexed between SPI and GPIO. For SPI, it is clock output SPI_CLK.
SPI_DI/ GPIO40	B3	I/O/Z	DV <sub>DD18</sub>	This pin is multiplexed between SPI and GPIO. For SPI, it is data input SPI_DI.
SPI_DO/ GPIO41	A2	I/O/Z	DV <sub>DD18</sub>	This pin is multiplexed between SPI and GPIO. For SPI it is data output SPI_DO.

- (1) I = Input, O = Output, Z = High impedance, S = Supply voltage, GND = Ground, A = Analog signal  
(2) Specifies the operating I/O supply voltage for each signal

**Table 2-14. EMAC and MDIO Terminal Functions**

SIGNAL NAME	NO.	TYPE <sup>(1)</sup>	OTHER <sup>(2)</sup>	DESCRIPTION
<b>EMAC</b>				
GPIOV33_0/ TXEN	B13	I/O/Z	DV <sub>DD33</sub>	This pin is multiplexed between GPIO and Ethernet MAC. In Ethernet MAC mode, it is Transmit Enable output TXEN.
GPIOV33_1/ TXCLK	A13	I/O/Z	DV <sub>DD33</sub>	This pin is multiplexed between GPIO and Ethernet MAC. In Ethernet MAC mode, it is Transmit Clock input TXCLK.
GPIOV33_2/ COL	A12	I/O/Z	DV <sub>DD33</sub>	This pin is multiplexed between GPIO and Ethernet MAC. In Ethernet MAC mode, it is Collision Detect input COL.
GPIOV33_6/ TXD3	C12	I/O/Z	DV <sub>DD33</sub>	This pin is multiplexed between GPIO and Ethernet MAC. In Ethernet MAC mode, it is Transmit Data 3 output TXD3.
GPIOV33_5/ TXD2	A11	I/O/Z	DV <sub>DD33</sub>	This pin is multiplexed between GPIO and Ethernet MAC. In Ethernet MAC mode, it is Transmit Data 2 output TXD2.
GPIOV33_4/ TXD1	D12	I/O/Z	DV <sub>DD33</sub>	This pin is multiplexed between GPIO and Ethernet MAC. In Ethernet MAC mode, it is Transmit Data 1 output TXD1.
GPIOV33_3/ TXD0	B12	I/O/Z	DV <sub>DD33</sub>	This pin is multiplexed between GPIO and Ethernet MAC. In Ethernet MAC mode, it is Transmit Data 0 output TXD0.
GPIOV33_11/ RXCLK	A10	I/O/Z	DV <sub>DD33</sub>	This pin is multiplexed between GPIO and Ethernet MAC. In Ethernet MAC mode, it is Receive Clock input RXCLK.
GPIOV33_12/ RXDV	D11	I/O/Z	DV <sub>DD33</sub>	This pin is multiplexed between GPIO and Ethernet MAC. In Ethernet MAC mode, it is Receive Data Valid input RXDV.
GPIOV33_13/ RXER	D10	I/O/Z	DV <sub>DD33</sub>	This pin is multiplexed between GPIO and Ethernet MAC. In Ethernet MAC mode, it is Receive Error input RXER.
GPIOV33_14/ CRS	C10	I/O/Z	DV <sub>DD33</sub>	This pin is multiplexed between GPIO and Ethernet MAC. In Ethernet MAC mode, it is Carrier Sense input CRS.
GPIOV33_10/ RXD3	E11	I/O/Z	DV <sub>DD33</sub>	This pin is multiplexed between GPIO and Ethernet MAC. In Ethernet MAC mode, it is Receive Data 3 input RXD3.
GPIOV33_9/ RXD2	B11	I/O/Z	DV <sub>DD33</sub>	This pin is multiplexed between GPIO and Ethernet MAC. In Ethernet MAC mode, it is Receive Data 2 input RXD2.
GPIOV33_8/ RXD1	C11	I/O/Z	DV <sub>DD33</sub>	This pin is multiplexed between GPIO and Ethernet MAC. In Ethernet MAC mode, it is Receive data 1 input RXD1.
GPIOV33_7/ RXD0	E12	I/O/Z	DV <sub>DD33</sub>	This pin is multiplexed between GPIO and Ethernet MAC. In Ethernet MAC mode, it is Receive Data 0 input RXD0.
<b>MDIO</b>				
GPIOV33_16/ MDCLK	B10	I/O/Z	DV <sub>DD33</sub>	This pin is multiplexed between GPIO and Ethernet MAC. In Ethernet MAC mode, it is Management Data Clock output MDCLK.
GPIOV33_15/ MDIO	E10	I/O/Z	DV <sub>DD33</sub>	This pin is multiplexed between GPIO and Ethernet MAC. In Ethernet MAC mode, it is Management Data IO MDIO.

(1) I = Input, O = Output, Z = High impedance, S = Supply voltage, GND = Ground, A = Analog signal

(2) Specifies the operating I/O supply voltage for each signal

**Table 2-15. GPIOV33 Terminal Functions**

SIGNAL NAME	NO.	TYPE <sup>(1)</sup>	OTHER <sup>(2)</sup>	DESCRIPTION
<b>GPIOV33</b>				
GPIOV33_16/ MDCLK	B10	I/O/Z	DV <sub>DD33</sub>	This pin is multiplexed between GPIO and Ethernet MAC. In GPIO mode, it is 3.3V GPIO GPIOV33_16.
GPIOV33_15/ MDIO	E10	I/O/Z	DV <sub>DD33</sub>	This pin is multiplexed between GPIO and Ethernet MAC. In GPIO mode, it is 3.3V GPIO GPIOV33_15.
GPIOV33_14/ CRS	C10	I/O/Z	DV <sub>DD33</sub>	This pin is multiplexed between GPIO and Ethernet MAC. In GPIO mode, it is 3.3V GPIO GPIOV33_14.
GPIOV33_13/ RXER	D10	I/O/Z	DV <sub>DD33</sub>	This pin is multiplexed between GPIO and Ethernet MAC. In GPIO mode, it is 3.3V GPIO GPIOV33_13.

(1) I = Input, O = Output, Z = High impedance, S = Supply voltage, GND = Ground, A = Analog signal

(2) Specifies the operating I/O supply voltage for each signal

**Table 2-15. GPIOV33 Terminal Functions (continued)**

SIGNAL NAME	NO.	TYPE <sup>(1)</sup>	OTHER <sup>(2)</sup>	DESCRIPTION
GPIOV33_12/ RXDV	D11	I/O/Z	DV <sub>DD33</sub>	This pin is multiplexed between GPIO and Ethernet MAC. In GPIO mode, it is 3.3V GPIO GPIOV33_12.
GPIOV33_11/ RXCLK	A10	I/O/Z	DV <sub>DD33</sub>	This pin is multiplexed between GPIO and Ethernet MAC. In GPIO mode, it is 3.3V GPIO GPIOV33_11.
GPIOV33_10/ RXD3	E11	I/O/Z	DV <sub>DD33</sub>	This pin is multiplexed between GPIO and Ethernet MAC. In GPIO mode, it is 3.3V GPIO GPIOV33_10.
GPIOV33_9/ RXD2	B11	I/O/Z	DV <sub>DD33</sub>	This pin is multiplexed between GPIO and Ethernet MAC. In GPIO mode, it is 3.3V GPIO GPIOV33_9.
GPIOV33_8/ RXD1	C11	I/O/Z	DV <sub>DD33</sub>	This pin is multiplexed between GPIO and Ethernet MAC. In GPIO mode, it is 3.3V GPIO GPIOV33_8.
GPIOV33_7/ RXD0	E12	I/O/Z	DV <sub>DD33</sub>	This pin is multiplexed between GPIO and Ethernet MAC. In GPIO mode, it is 3.3V GPIO GPIOV33_7.
GPIOV33_6/ TXD3	C12	I/O/Z	DV <sub>DD33</sub>	This pin is multiplexed between GPIO and Ethernet MAC. In GPIO mode, it is 3.3V GPIO GPIOV33_6.
GPIOV33_5/ TXD2	A11	I/O/Z	DV <sub>DD33</sub>	This pin is multiplexed between GPIO and Ethernet MAC. In GPIO mode, it is 3.3V GPIO GPIOV33_5.
GPIOV33_4/ TXD1	D12	I/O/Z	DV <sub>DD33</sub>	This pin is multiplexed between GPIO and Ethernet MAC. In GPIO mode, it is 3.3V GPIO GPIOV33_4.
GPIOV33_3/ TXD0	B12	I/O/Z	DV <sub>DD33</sub>	This pin is multiplexed between GPIO and Ethernet MAC. In GPIO mode, it is 3.3V GPIO GPIOV33_3.
GPIOV33_2/ COL	A12	I/O/Z	DV <sub>DD33</sub>	This pin is multiplexed between GPIO and Ethernet MAC. In GPIO mode, it is 3.3V GPIO GPIOV33_2.
GPIOV33_1/ TXCLK	A13	I/O/Z	DV <sub>DD33</sub>	This pin is multiplexed between GPIO and Ethernet MAC. In GPIO mode, it is 3.3V GPIO GPIOV33_1.
GPIOV33_0/ TXEN	B13	I/O/Z	DV <sub>DD33</sub>	This pin is multiplexed between GPIO and Ethernet MAC. In GPIO mode, this pin is 3.3V GPIO pin GPIOV33_0.

**Table 2-16. Standalone GPIOV18 Terminal Functions**

SIGNAL NAME	NO.	TYPE <sup>(1)</sup>	OTHER <sup>(2)</sup>	DESCRIPTION
<b>Standalone GPIOV18</b>				
GPIO7	C3	I/O/Z	DV <sub>DD18</sub>	This pin is standalone and functions as GPIO7.

- (1) I = Input, O = Output, Z = High impedance, S = Supply voltage, GND = Ground, A = Analog signal  
(2) Specifies the operating I/O supply voltage for each signal

**Table 2-17. USB Terminal Functions**

SIGNAL NAME	NO.	TYPE <sup>(1)</sup>	OTHER <sup>(2)(3)</sup>	DESCRIPTION
<b>USB 2.0</b>				
M24XI	F18	I	DV <sub>DD18</sub>	Crystal input for M24 oscillator (24 MHz for USB). If a crystal input <b>is not</b> used, but instead a physical clock-in source is supplied, this is the external oscillator clock input. When the USB peripheral <b>is not</b> used, M24XI should be left as a No Connect.
M24XO	F19	O	DV <sub>DD18</sub>	Crystal output for M24 oscillator. If a crystal input <b>is not</b> used, but instead a physical clock-in source is supplied, M24XO should be left as a No Connect. When the USB peripheral <b>is not</b> used, M24XO should be left as a No Connect.
M24V <sub>DD</sub>	F16	S	<sup>(3)</sup>	1.8-V power supply for M24 oscillator. If a crystal input <b>is not</b> used, but instead a physical clock-in source is supplied, M24V <sub>DD</sub> should still be connected to the 1.8-V power supply. When the USB peripheral <b>is not</b> used, M24V <sub>DD</sub> should be connected to the 1.8-V power supply.
M24V <sub>SS</sub>	F17	GND	<sup>(3)</sup>	Ground for M24 oscillator. If a crystal input <b>is not</b> used, but instead a physical clock-in source is supplied, M24V <sub>SS</sub> should still be connected to ground. When the USB peripheral <b>is not</b> used, M24V <sub>SS</sub> should be connected to ground.
USB_VBUS	J17	A I/O	<sup>(3)</sup>	5-V input that signifies that VBUS is connected. When the USB peripheral <b>is not</b> used, the USB_VBUS signal should be either pulled down or pulled up via a 10-kΩ resistor.
USB_ID	J16	A I/O		USB operating mode identification pin. For Host mode operation, pull down this pin to ground (V <sub>SS</sub> ) via an external 1.5-kΩ resistor. For Device mode operation, pull up this pin to DV <sub>DD33</sub> rail via an external 1.5-kΩ resistor. When the USB peripheral <b>is not</b> used, the USB_ID signal should be either pulled down or pulled up via a 10-kΩ resistor.
USB_DP	G19	A I/O		USB bi-directional Data Differential signal pair [positive/negative]. When the USB peripheral <b>is not</b> used, the USB_DP signal should be pulled high and the USB_DM signal should be pulled down via a 10-kΩ resistor.
USB_DM	H19	A I/O		
USB_R1	H18	A I/O	<sup>(3)</sup>	Reference current output. This must be connected via a 10-kΩ ±1% resistor to USB_V <sub>SSREF</sub> . When the USB peripheral <b>is not</b> used, the USB_R1 signal should be connected via a 10-kΩ resistor to USB_V <sub>SSREF</sub> .
USB_V <sub>SSREF</sub>	G16	GND	<sup>(3)</sup>	Ground for reference current. This must be connected via a 10-kΩ ±1% resistor to USB_R1. When the USB peripheral <b>is not</b> used, the USB_V <sub>SSREF</sub> signal should be connected to V <sub>SS</sub> .
USB_V <sub>DDA3P3</sub>	J19	S	<sup>(3)</sup>	Analog 3.3 V power supply for USB phy. When the USB peripheral <b>is not</b> used, the USB_V <sub>DDA3P3</sub> signal should be connected to DV <sub>DD33</sub> .
USB_V <sub>SSA3P3</sub>	J18	GND	<sup>(3)</sup>	Analog ground for USB phy. When the USB peripheral <b>is not</b> used, the USB_V <sub>SSA3P3</sub> signal should be connected to V <sub>SS</sub> .
USB_V <sub>DD1P8</sub>	H17	S	<sup>(3)</sup>	1.8-V I/O power supply for USB phy. When the USB peripheral <b>is not</b> used, the USB_V <sub>DD1P8</sub> signal should be connected to DV <sub>DD18</sub> .

(1) I = Input, O = Output, Z = High impedance, S = Supply voltage, GND = Ground, A = Analog signal

(2) Specifies the operating I/O supply voltage for each signal

(3) For more information, see the *Recommended Operating Conditions* table

**Table 2-17. USB Terminal Functions (continued)**

SIGNAL NAME	NO.	TYPE <sup>(1)</sup>	OTHER <sup>(2)(3)</sup>	DESCRIPTION
USB_VSS1P8	H16	GND	(3)	I/O Ground for USB phy. When the USB peripheral <i>is not</i> used, the USB_VSS1P8 signal should be connected to V <sub>SS</sub> .
USB_VDDA1P2LDO	G18	S	(3)	Core Power supply LDO output for USB phy. This must be connected via a 1-μF capacitor to V <sub>SS</sub> . When the USB peripheral <i>is not</i> used, the USB_VDDA1P2LDO signal should still be connected via a 1-μF capacitor to V <sub>SS</sub> .
USB_VSSA1P2LDO	G17	GND	(3)	Core Ground for USB phy. This is the ground for the LDO and must be connected to V <sub>SS</sub> . When the USB peripheral <i>is not</i> used, the USB_VSSA1P2LDO signal should still be connected to V <sub>SS</sub> .

**Table 2-18. VLYNQ Terminal Functions**

SIGNAL NAME	NO.	TYPE <sup>(1)</sup>	OTHER <sup>(2)</sup>	DESCRIPTION
<b>VLYNQ</b>				
EM_CS5/ GPIO8/ VLYNQ_CLOCK	T1	I/O/Z	DV <sub>DD18</sub>	This pin is multiplexed between EMIFA, GPIO, and VLYNQ. For VLYNQ, it is the clock (VLYNQ_CLOCK).
EM_CS4/ GPIO9/ VLYNQ_SCRUN	T2	I/O/Z	DV <sub>DD18</sub>	This pin is multiplexed between EMIFA, GPIO, and VLYNQ. For VLYNQ, it is the Serial Clock run request (VLYNQ_SCRUN).
EM_A[15]/ GPIO16/ VLYNQ_TXD3	P3	I/O/Z	DV <sub>DD18</sub>	This pin is multiplexed between EMIFA, GPIO, and VLYNQ. For VLYNQ, it is transmit bus bit 3 output VLYNQ_TXD3.
EM_A[17]/ GPIO14/ VLYNQ_TXD2	R2	I/O/Z	DV <sub>DD18</sub>	This pin is multiplexed between EMIFA, GPIO, and VLYNQ. For VLYNQ, it is transmit bus bit 2 output VLYNQ_TXD2.
EM_A[19]/ GPIO12/ VLYNQ_TXD1	R4	I/O/Z	DV <sub>DD18</sub>	This pin is multiplexed between EMIFA, GPIO, and VLYNQ. For VLYNQ, it is transmit bus bit 1 output VLYNQ_TXD1.
EM_A[21]/ GPIO10/ VLYNQ_TXD0	T3	I/O/Z	DV <sub>DD18</sub>	This pin is multiplexed between EMIFA, GPIO, and VLYNQ. For VLYNQ, it is bit 0 of the transmit bus (VLYNQ_TXD0).
EM_A[14]/ GPIO17/ VLYNQ_RXD3	P4	I/O/Z	DV <sub>DD18</sub>	This pin is multiplexed between EMIFA, GPIO, and VLYNQ. For VLYNQ, it is receive bus bit 3 input VLYNQ_RXD3.
EM_A[16]/ GPIO15/ VLYNQ_RXD2	R5	I/O/Z	DV <sub>DD18</sub>	This pin is multiplexed between EMIFA, GPIO, and VLYNQ. For VLYNQ, it is receive bus bit 2 input VLYNQ_RXD2.
EM_A[18]/ GPIO13/ VLYNQ_RXD1	P5	I/O/Z	DV <sub>DD18</sub>	This pin is multiplexed between EMIFA, GPIO, and VLYNQ. For VLYNQ, it is receive bus bit 1 input VLYNQ_RXD1.
EM_A[20]/ GPIO11/ VLYNQ_RXD0	R3	I/O/Z	DV <sub>DD18</sub>	This pin is multiplexed between EMIFA, GPIO, and VLYNQ. For VLYNQ, it is receive bus bit 0 input VLYNQ_RXD0.

(1) I = Input, O = Output, Z = High impedance, S = Supply voltage, GND = Ground, A = Analog signal

(2) Specifies the operating I/O supply voltage for each signal

**Table 2-19. VPFE Terminal Functions**

SIGNAL NAME	NO.	TYPE <sup>(1)</sup>	OTHER <sup>(2)(3)</sup>	DESCRIPTION
<b>VIDEO/IMAGE IN (VPFE)</b>				
PCLK	M19	I	– DV <sub>DD18</sub>	Pixel clock input used to load image data into the CCD Controller (CCDC) on pins CI[7:0] and YI[7:0].
VD	L19	I/O/Z	– DV <sub>DD18</sub>	Vertical synchronization signal that can be either an input (slave mode) or an output (master mode), which signals the start of a new frame to the CCDC.
HD	M18	I/O/Z	– DV <sub>DD18</sub>	Horizontal synchronization signal that can be either an input (slave mode) or an output (master mode), which signals the start of a new line to the CCDC.
C17/ CCD15/ UART_RXD2	N19	I/O/Z	IPD DV <sub>DD18</sub>	This pin is multiplexed between the CCDC and UART2. When used by the CCDC as input C17, it supports several modes. In 16-bit CCD Analog-Front-End (AFE) mode, it is input CCD15. In 16-bit YCbCr mode, it is time multiplexed between CB7 and CR7 inputs. In 8-bit YCbCr mode, it is time multiplexed between Y7, CB7, and CR7 of the upper 8-bit channel.
C16/ CCD14/ UART_TXD2	N18	I/O/Z	IPD DV <sub>DD18</sub>	This pin is multiplexed between the CCDC and UART2. When used by the CCDC as input C16, it supports several modes. In 16-bit CCD AFE mode, it is input CCD14. In 16-bit YCbCr mode, it is time multiplexed between CB6 and CR6 inputs. In 8-bit YCbCr mode, it is time multiplexed between Y6, CB6, and CR6 of the upper 8-bit channel.
C15/ CCD13/ UART_CTS2	N17	I/O/Z	IPD DV <sub>DD18</sub>	This pin is multiplexed between the CCDC and UART2. When used by the CCDC as input C15, it supports several modes. In 16-bit CCD AFE mode, it is input CCD13. In 16-bit YCbCr mode, it is time multiplexed between CB5 and CR5 inputs. In 8-bit YCbCr mode, it is time multiplexed between Y5, CB5, and CR5 of the upper 8-bit channel.
C14/ CCD12/ UART_RTS2	N16	I/O/Z	IPD DV <sub>DD18</sub>	This pin is multiplexed between the CCDC and UART2. When used by the CCDC as input C14, it supports several modes. In 16-bit CCD AFE mode, it is input CCD12. In 16-bit YCbCr mode, it is time multiplexed between CB4 and CR4 inputs. In 8-bit YCbCr mode, it is time multiplexed between Y4, CB4, and CR4 of the upper 8-bit channel.
C13/ CCD11	N15	I	IPD DV <sub>DD18</sub>	This pin is CCDC input C13 and it supports several modes. In 16-bit CCD AFE mode, it is input CCD11. In 16-bit YCbCr mode, it is time multiplexed between CB3 and CR3 inputs. In 8-bit YCbCr mode, it is time multiplexed between Y3, CB3, and CR3 of the upper 8-bit channel.
C12/ CCD10	M17	I	IPD DV <sub>DD18</sub>	This pin is CCDC input C12 and it supports several modes. In 16-bit CCD AFE mode, it is input CCD10. In 16-bit YCbCr mode, it is time multiplexed between CB2 and CR2 inputs. In 8-bit YCbCr mode, it is time multiplexed between Y2, CB2, and CR2 of the upper 8-bit channel.
C11/ CCD9	M16	I	IPD DV <sub>DD18</sub>	This pin is CCDC input C11 and it supports several modes. In 16-bit CCD AFE mode, it is input CCD9. In 16-bit YCbCr mode, it is time multiplexed between CB1 and CR1 inputs. In 8-bit YCbCr mode, it is time multiplexed between Y1, CB1, and CR1 of the upper 8-bit channel.
C10/ CCD8	M15	I	IPD DV <sub>DD18</sub>	This pin is CCDC input C10 and it supports several modes. In 16-bit CCD AFE mode, it is input CCD8. In 16-bit YCbCr mode, it is time multiplexed between CB0 and CR0 inputs. In 8-bit YCbCr mode, it is time multiplexed between Y0, CB0, and CR0 of the upper 8-bit channel.
Y17/ CCD7	L18	I	IPD DV <sub>DD18</sub>	This pin is CCDC input Y17 and it supports several modes. In 16-bit CCD AFE mode, it is input CCD7. In 16-bit YCbCr mode, it is input Y7. In 8-bit YCbCr mode, it is time multiplexed between Y7, CB7, and CR7 of the lower 8-bit channel.

(1) I = Input, O = Output, Z = High impedance, S = Supply voltage, GND = Ground, A = Analog signal

(2) IPD = Internal pulldown, IPU = Internal pullup. (To pull up a signal to the opposite supply rail, a 1-kΩ resistor should be used.)

(3) Specifies the operating I/O supply voltage for each signal



**Table 2-19. VPFE Terminal Functions (continued)**

SIGNAL NAME	NO.	TYPE <sup>(1)</sup>	OTHER <sup>(2)(3)</sup>	DESCRIPTION
Y16/ CCD6	L17	I	IPD DV <sub>DD18</sub>	This pin is CCD input Y16 and it supports several modes. In 16-bit CCD AFE mode, it is input CCD6. In 16-bit YCbCr mode, it is input Y6. In 8-bit YCbCr mode, it is time multiplexed between Y6, CB6, and CR6 of the lower 8-bit channel.
Y15/ CCD5	L16	I	IPD DV <sub>DD18</sub>	This pin is CCD input Y15 and it supports several modes. In 16-bit CCD AFE mode, it is input CCD5. In 16-bit YCbCr mode, it is input Y5. In 8-bit YCbCr mode, it is time multiplexed between Y5, CB5, and CR5 of the lower 8-bit channel.
Y14/ CCD4	L15	I	IPD DV <sub>DD18</sub>	This pin is CCD input Y14 and it supports several modes. In 16-bit CCD Analog-Front-End (AFE) mode, it is input CCD4. In 16-bit YCbCr mode, it is input Y4. In 8-bit YCbCr mode, it is time multiplexed between Y4, CB4, and CR4 of the lower 8-bit channel.
Y13/ CCD3	K19	I	IPD DV <sub>DD18</sub>	This pin is CCD input Y13 and it supports several modes. In 16-bit CCD AFE mode, it is input CCD3. In 16-bit YCbCr mode, it is input Y3. In 8-bit YCbCr mode, it is time multiplexed between Y3, CB3, and CR3 of the lower 8-bit channel.
Y12/ CCD2	K18	I	IPD DV <sub>DD18</sub>	This pin is CCD input Y12 and it supports several modes. In 16-bit CCD AFE mode, it is input CCD2. In 16-bit YCbCr mode, it is input Y2. In 8-bit YCbCr mode, it is time multiplexed between Y2, CB2, and CR2 of the lower 8-bit channel.
Y11/ CCD1	K17	I	IPD DV <sub>DD18</sub>	This pin is CCD input Y11 and it supports several modes. In 16-bit CCD AFE mode, it is input CCD1. In 16-bit YCbCr mode, it is input Y1. In 8-bit YCbCr mode, it is time multiplexed between Y1, CB1, and CR1 of the lower 8-bit channel.
Y10/ CCD0	K16	I	IPD DV <sub>DD18</sub>	This pin is CCD input Y10 and it supports several modes. In 16-bit CCD AFE mode, it is input CCD0. In 16-bit YCbCr mode, it is input Y0. In 8-bit YCbCr mode, it is time multiplexed between Y0, CB0, and CR0 of the lower 8-bit channel.
GPIO1/ C_WE	E13	I/O/Z	DV <sub>DD18</sub>	This pin is multiplexed between GPIO and the VPFE. In VPFE mode, it is the CCD Controller write enable input C_WE.
GPIO4/ R0/ C_FIELD	B14	I/O/Z	DV <sub>DD18</sub>	This pin is multiplexed between GPIO, the VPFE, and the VPBE. In VPFE mode, it is CCD field identification bidirectional signal C_FIELD.

**Table 2-20. VPBE Terminal Functions**

SIGNAL NAME	NO.	TYPE <sup>(1)</sup>	OTHER <sup>(2)(3)</sup>	DESCRIPTION
<b>VIDEO OUT (VPBE)</b>				
HSYNC	C17	I/O/Z	IPD DV <sub>DD18</sub>	VPBE Horizontal Sync signal that can be either an input or an output.
VSYNC	C18	I/O/Z	IPD DV <sub>DD18</sub>	VPBE Vertical Sync signal that can be either an input or an output.
VCLK	D19	I/O/Z	DV <sub>DD18</sub>	VPBE Clock Output
VPBECLK	C19	I/O/Z	IPD DV <sub>DD18</sub>	VPBE Clock Input
COUT0/ B3/ BTSEL0	A16	I/O/Z	IPD DV <sub>DD18</sub>	This pin is multiplexed between ARM boot mode and the VPBE. After reset, this pin is either video encoder outputs COUT0, or RGB666/888 Blue output data bits 3, B3.

(1) I = Input, O = Output, Z = High impedance, S = Supply voltage, GND = Ground, A = Analog signal

(2) IPD = Internal pulldown, IPU = Internal pullup. (To pull up a signal to the opposite supply rail, a 1-kΩ resistor should be used.)

(3) Specifies the operating I/O supply voltage for each signal

**Table 2-20. VPBE Terminal Functions (continued)**

SIGNAL		NO.	TYPE <sup>(1)</sup>	OTHER <sup>(2)(3)</sup>	DESCRIPTION
NAME					
COUT1/ B4/ BTSEL1		B16	I/O/Z	IPD DV <sub>DD18</sub>	This pin is multiplexed between ARM boot mode and the VPBE. After reset, this pin is either video encoder outputs COUT1, or RGB666/888 Blue output data bits 4, B4.
COUT2/ B5/ EM_WIDTH		A17	I/O/Z	IPD DV <sub>DD18</sub>	This pin is multiplexed between EMIFA and the VPBE. After reset, it is video encoder output COUT2 or RGB666/888 Blue output data bit 5 B5.
COUT3/ B6/ DSP_BT		B17	I/O/Z	IPD DV <sub>DD18</sub>	This pin is multiplexed between DSP boot and the VPBE. After reset, it is video encoder output COUT3 or RGB666/888 Blue data bit 6 output B6.
COUT4/ B7		A18	O	DV <sub>DD18</sub>	Video encoder output COUT4 or RGB666/888 Blue data bit 7 output B7.
COUT5/ G2		B18	O	DV <sub>DD18</sub>	Video encoder output COUT5 or RGB666/888 Green data bit 2 output G2.
COUT6/ G3		B19	O	DV <sub>DD18</sub>	Video encoder output COUT6 or RGB666/888 Green data bit 3 output G3.
COUT7/ G4		C16	O	DV <sub>DD18</sub>	Video encoder output COUT7 or RGB666/888 Green data bit 4 output G4.
YOUT0/ G5/ AEAW0		D15	I/O/Z	IPD DV <sub>DD18</sub>	These pins are multiplexed between EMIFA and the VPBE. After reset, these are video encoder outputs YOUT[0:4] or RGB666/888 Red and Green data bit outputs G5, G6, G7, R3, and R4.
YOUT1/ G6/ AEAW1		D16	I/O/Z	IPD DV <sub>DD18</sub>	
YOUT2/ G7/ AEAW2		D17	I/O/Z	IPD DV <sub>DD18</sub>	
YOUT3/ R3/ AEAW3		D18	I/O/Z	IPD DV <sub>DD18</sub>	
YOUT4/ R4/ AEAW4		E15	I/O/Z	IPD DV <sub>DD18</sub>	
YOUT5/ R5		E16	O	DV <sub>DD18</sub>	Video encoder output YOUT5 or RGB666/888 Red data bit 5 output R5.
YOUT6/ R6		E17	O	DV <sub>DD18</sub>	Video encoder output YOUT6 or RGB666/888 Red data bit 6 output R6.
YOUT7/ R7		E18	O	DV <sub>DD18</sub>	Video encoder output YOUT7 or RGB666/888 Red data bit 7 output R7.
GPIO0/ LCD_OE		C13	I/O/Z	DV <sub>DD18</sub>	This pin is multiplexed between GPIO and the VPBE. In VPBE mode, it is the LCD output enable LCD_OE.
GPIO2/ G0		D13	I/O/Z	DV <sub>DD18</sub>	This pin is multiplexed between GPIO and the VPBE. In VPBE mode, it is RGB888 Green data bit 0 output G0.
GPIO3/ B0/ LCD_FIELD		C14	I/O/Z	DV <sub>DD18</sub>	This pin is multiplexed between GPIO, and the VPBE. In VPBE mode, it is RGB888 Blue data bit 0 output B0 or LCD interlaced bidirectional LCD_FIELD.
GPIO4/ R0/ C_FIELD		B14	I/O/Z	DV <sub>DD18</sub>	This pin is multiplexed between GPIO, the VPFE, and the VPBE. In VPBE mode, it is RGB888 Red data bit 0 output R0.
GPIO5/ G1		E14	I/O/Z	DV <sub>DD18</sub>	This pin is multiplexed between GPIO and the VPBE. In VPBE mode, it is RGB888 Green data bit 1 output G1.
GPIO6/ B1		A14	I/O/Z	DV <sub>DD18</sub>	This pin is multiplexed between GPIO and the VPBE. In VPBE mode, it is RGB888 Blue data bit 1 output B1.
GPIO38/ R1		D14	I/O/Z	DV <sub>DD18</sub>	This pin is multiplexed between VPBE and GPIO. In VPBE mode, it is RGB888 Red output data bit 1.
PWM1/ R2/ GPIO46		B15	I/O/Z	DV <sub>DD18</sub>	This pin is multiplexed between PWM1, VPBE, and GPIO. In VPBE mode, it is RGB888 Red output bit 2 (R2).

**Table 2-20. VPBE Terminal Functions (continued)**

SIGNAL		NO.	TYPE <sup>(1)</sup>	OTHER <sup>(2)(3)</sup>	DESCRIPTION
NAME					
PWM2/ B2/ GPIO47	A15		I/O/Z	DV <sub>DD18</sub>	This pin is multiplexed between PWM2, VPBE, and GPIO. In VPBE mode, it is RGB888 Blue output bit 2 (B2).

**Table 2-21. DAC [Part of VPBE] Terminal Functions**

SIGNAL		NO.	TYPE <sup>(1)</sup>	OTHER <sup>(2)(3)</sup>	DESCRIPTION
NAME					
<b>DAC[A:D]</b>					
DAC_VREF	R17	A I	(3)		Reference voltage input (0.5 V). When the DAC is not used, the DAC_VREF signal should be connected to V <sub>SS</sub> .
DAC_IOUT_A	P19	A O			Output of DAC A. When the DAC is not used, the DAC_IOUT_A signal should be left as a No Connect.
DAC_IOUT_B	P18	A O			Output of DAC B. When the DAC is not used, the DAC_IOUT_B signal should be left as a No Connect.
DAC_IOUT_C	R19	A O			Output of DAC C. When the DAC is not used, the DAC_IOUT_C signal should be left as a No Connect.
DAC_IOUT_D	T19	A O			Output of DAC D. When the DAC is not used, the DAC_IOUT_D signal should be left as a No Connect.
V <sub>DDA_1P8V</sub>	R18	S	(3)		1.8-V analog I/O power. When the DAC is not used, the V <sub>DDA_1P8V</sub> signal should be connected to V <sub>SS</sub> .
V <sub>SSA_1P8V</sub>	P17	GND	(3)		Analog I/O ground. When the DAC is not used, the V <sub>SSA_1P8V</sub> signal should be connected to V <sub>SS</sub> .
V <sub>DDA_1P1V</sub>	P16	S	(3)		1.20-V analog core supply voltage. When the DAC is not used, the V <sub>DDA_1P1V</sub> signal should be connected to V <sub>SS</sub> .
V <sub>SSA_1P1V</sub>	T18	GND	(3)		Analog core ground. When the DAC is not used, the V <sub>SSA_1P1V</sub> signal should be connected to V <sub>SS</sub> .
DAC_RBIAS	R16	A I	(3)		External resistor connection for current bias configuration. This pin must be connected via a 4-kΩ resistor to V <sub>SSA_1P8V</sub> . When the DAC is not used, the DAC_RBIAS signal should be connected to V <sub>SS</sub> .

(1) I = Input, O = Output, Z = High impedance, S = Supply voltage, GND = Ground, A = Analog signal

(2) Specifies the operating I/O supply voltage for each signal

(3) For more information, see the *Recommended Operating Conditions* table

**Table 2-22. UART0, UART1, UART2 Terminal Functions**

<b>SIGNAL NAME</b>	<b>NO.</b>	<b>TYPE<sup>(1)</sup></b>	<b>OTHER<sup>(2)(3)</sup></b>	<b>DESCRIPTION</b>
<b>UART2</b>				
C17/ CCD15/ UART_RXD2	N19	I/O/Z	IPD DV <sub>DD18</sub>	This pin is multiplexed between the CCDC and UART2. When used by UART2 it is the receive data input UART_RXD2.
C16/ CCD14/ UART_TXD2	N18	I/O/Z	IPD DV <sub>DD18</sub>	This pin is multiplexed between the CCDC and UART2. In UART2 mode, it is the transmit data output UART_TXD2.
C15/ CCD13/ UART_CTS2	N17	I/O/Z	IPD DV <sub>DD18</sub>	This pin is multiplexed between the CCDC and UART2. In UART2 mode, it is the clear to send input UART_CTS2.
C14/ CCD12/ UART_RTS2	N16	I/O/Z	IPD DV <sub>DD18</sub>	This pin is multiplexed between the CCDC and UART2. In UART2 mode, it is the ready to send output UART_RTS2.
<b>UART1</b>				
DMACK/ UART_TXD1	H3	I/O/Z	DV <sub>DD18</sub>	This pin is multiplexed between ATA/CF and UART1. For UART1, it is transmit data output UART_TXD1.
DMARQ/ UART_RXD1	G1	I/O/Z	IPD DV <sub>DD18</sub>	This pin is multiplexed between ATA/CF and UART1. For UART1, it is receive data input UART_RXD1.
<b>UART0</b>				
UART_RXD0/ GPIO35	D5	I/O/Z	DV <sub>DD18</sub>	This pin is multiplexed between UART0 and GPIO. For UART0, it is receive data input UART_RXD0.
UART_TXD0/ GPIO36	C5	I/O/Z	DV <sub>DD18</sub>	This pin is multiplexed between UART0 and GPIO. For UART0, it is transmit data output UART_TXD0.

- (1) I = Input, O = Output, Z = High impedance, S = Supply voltage, GND = Ground, A = Analog signal  
(2) IPD = Internal pulldown, IPU = Internal pullup. (To pull up a signal to the opposite supply rail, a 1-kΩ resistor should be used.)  
(3) Specifies the operating I/O supply voltage for each signal

**Table 2-23. PWM0, PWM1, PWM2 Terminal Functions**

<b>SIGNAL NAME</b>	<b>NO.</b>	<b>TYPE<sup>(1)</sup></b>	<b>OTHER<sup>(2)</sup></b>	<b>DESCRIPTION</b>
<b>PWM2</b>				
PWM2/ B2/ GPIO47	A15	I/O/Z	DV <sub>DD18</sub>	This pin is multiplexed between PWM2, VPBE, and GPIO. For PWM2, it is output PWM2.
<b>PWM1</b>				
PWM1/ R2/ GPIO46	B15	I/O/Z	DV <sub>DD18</sub>	This pin is multiplexed between PWM1, VPBE, and GPIO. For PWM1, it is output PWM1.
<b>PWM0</b>				
PWM0/ GPIO45	C15	I/O/Z	DV <sub>DD18</sub>	This pin is multiplexed between PWM0 and GPIO. For PWM0, it is output PWM0.

(1) I = Input, O = Output, Z = High impedance, S = Supply voltage, GND = Ground, A = Analog signal

(2) Specifies the operating I/O supply voltage for each signal

**Table 2-24. ATA/CF Terminal Functions**

SIGNAL NAME	NO.	TYPE <sup>(1)</sup>	OTHER <sup>(2)(3)</sup>	DESCRIPTION
<b>ATA/CF</b>				
SPI_EN1/ HDDIR/ GPIO42	B2	I/O/Z	DV <sub>DD18</sub>	This pin is multiplexed between SPI, ATA, and GPIO. For ATA, it is buffer direction control output HDDIR.
GPIO50/ ATA_CS0	J5	O	DV <sub>DD18</sub>	This pin is multiplexed between GPIO and ATA/CF. In ATA mode, it is ATA/CF chip select output ATA_CS0.
GPIO51/ ATA_CS1	H1	O	DV <sub>DD18</sub>	This pin is multiplexed between GPIO and ATA/CF. In ATA mode, it is ATA/CF chip select output ATA_CS1.
EM_R $\overline{W}$ / INTRQ/ H $\overline{W}$	G3	I	DV <sub>DD18</sub>	This pin is multiplexed between EMIFA, ATA/CF, and HPI. For ATA/CF, it is interrupt request input INTRQ.
EM_WAIT/ (RDY/BSY)/ IORDY/ HRDY	F1	I	IPU DV <sub>DD18</sub>	This pin is multiplexed between EMIFA (NAND/SmartMedia/xD), ATA/CF, and HPI. For ATA/CF, it is IO Ready input IORDY.
EM_OE/ (RE)/ (IORD)/ DIOR/ HDS1	H4	O	DV <sub>DD18</sub>	This pin is multiplexed between EMIFA (NAND/SmartMedia/xD), ATA/CF, and HPI. For CF, it is read strobe output (IORD). For ATA, it is read strobe output DIOR.
EM_WE (WE) (IOWR)/ DIOW/ HDS2	G2	O	DV <sub>DD18</sub>	This pin is multiplexed between EMIFA (NAND/SmartMedia/xD), ATA/CF, and HPI. For CF, it is write strobe output (IOWR). For ATA, it is write strobe output DIOW.
DMACK/ UART_TXD1	H3	O	DV <sub>DD18</sub>	This pin is multiplexed between ATA/CF and UART1. For ATA/CF, it is DMA acknowledge output DMACK.
DMARQ/ UART_RXD1	G1	O	IPD DV <sub>DD18</sub>	This pin is multiplexed between ATA/CF and UART1. For ATA/CF, it is DMA request DMARQ input.

- (1) I = Input, O = Output, Z = High impedance, S = Supply voltage, GND = Ground, A = Analog signal  
(2) IPD = Internal pulldown, IPU = Internal pullup. (To pull up a signal to the opposite supply rail, a 1-k $\Omega$  resistor should be used.)  
(3) Specifies the operating I/O supply voltage for each signal

**Table 2-24. ATA/CF Terminal Functions (continued)**

SIGNAL		TYPE <sup>(1)</sup>	OTHER <sup>(2)(3)</sup>	DESCRIPTION
NAME	NO.			
EM_D15/ DD15/ HD15	E1	I/O/Z	DV <sub>DD18</sub>	These pins are multiplexed between EMIFA (NAND), ATA/CF, and HPI. In all cases they are used as a 16 bit bi-directional data bus. For ATA/CF, these are DD[15:0].
EM_D14/ DD14/ HD14	H5			
EM_D13/ DD13/ HD13	F2			
EM_D12/ DD12/ HD12	D1			
EM_D11/ DD11/ HD11	G4			
EM_D10/ DD10/ HD10	G5			
EM_D9/ DD9/ HD9	E2			
EM_D8/ DD8/ HD8	F3			
EM_D7/ DD7/ HD7	C1			
EM_D6/ DD6/ HD6	F4			
EM_D5/ DD5/ HD5	D2			
EM_D4/ DD4/ HD4	E4			
EM_D3/ DD3/ HD3	E3			
EM_D2/ DD2/ HD2	F5			
EM_D1/ DD1/ HD1	D3			
EM_D0/ DD0/ HD0	E5			
EM_A[0]/ DA2/ HCNTL1/ GPIO53	J4	I/O/Z	DV <sub>DD18</sub>	This pin is multiplexed between EMIFA, ATA/CF, HPI, and GPIO. For ATA/CF, it is Device address bit 2 output DA2.
EM_BA[1]/ DA1/ GPIO52	H2	I/O/Z	DV <sub>DD18</sub>	This pin is multiplexed between EMIFA, ATA/CF, and GPIO. For ATA/CF, it is Device address bit 1 output DA1.
EM_BA[0]/ DA0/ HINT	J3	I/O/Z	DV <sub>DD18</sub>	This pin is multiplexed between EMIFA, ATA/CF, HPI. For ATA/CF, it is Device address bit 0 output DA0.

**Table 2-25. MMC/SD/SDIO Terminal Functions**

SIGNAL NAME	NO.	TYPE <sup>(1)</sup>	OTHER <sup>(2)</sup>	DESCRIPTION
<b>MMC/SD/SDIO</b>				
SD_CLK	A9	O	DV <sub>DD33</sub>	Data clock output SD_CLK
SD_CMD	B9	I/O/Z	DV <sub>DD33</sub>	Bi-directional command IO SD_CMD
SD_DATA3	C9	I/O/Z	DV <sub>DD33</sub>	These pins are the nibble wide bi-directional data bus SD_DATA[3:0].
SD_DATA2	D9	I/O/Z		
SD_DATA1	E9	I/O/Z		
SD_DATA0	D8	I/O/Z		

(1) I = Input, O = Output, Z = High impedance, S = Supply voltage, GND = Ground, A = Analog signal

(2) Specifies the operating I/O supply voltage for each signal



**Table 2-26. HPI Terminal Functions**

<b>SIGNAL NAME</b>	<b>NO.</b>	<b>TYPE<sup>(1)</sup></b>	<b>OTHER<sup>(2)(3)</sup></b>	<b>DESCRIPTION</b>
<b>Host-Port Interface (HPI)</b>				
$\overline{\text{EM\_CS3}}$	B1	I/O/Z	DV <sub>DD18</sub>	For EMIFA, this pin is Chip Select 3 output. In HPI mode this pin must be pulled high via an external 10-k $\Omega$ resistor.
EM_BA[0]/ DA0/ HINT	J3	I/O/Z	DV <sub>DD18</sub>	This pin is multiplexed between EMIFA, ATA/CF, and HPI. In HPI mode, it is the host interrupt output HINT.
EM_A[0]/ DA2/ HCNTL1/ GPIO53	J4	I/O/Z	DV <sub>DD18</sub>	This pin is multiplexed between EMIFA, ATA/CF, HPI, and GPIO. For HPI, it is control input HCNTL1. The state of HCNTL1 and HCNTL0 determine if address, data, or control information is being transmitted between an external host and DM644X.
EM_A[2]/ (CLE)/ HCNTL0	J1	I/O/Z	DV <sub>DD18</sub>	This pin is multiplexed between EMIFA (NAND/SmartMedia/xD), and HPI. In HPI mode, it is control input HCNTL0. The state of HCNTL1 and HCNTL0 determine if address, data, or control information is being transmitted between an external host and DM644X.
EM_A[1]/ (ALE)/ HHWIL	J2	I/O/Z	DV <sub>DD18</sub>	This pin is multiplexed between EMIFA (NAND/SmartMedia/xD), and HPI. In HPI mode, it is Half-word identification input HHWIL.
EM_R $\overline{\text{W}}$ / INTRQ/ HR $\overline{\text{W}}$	G3	I/O/Z	DV <sub>DD18</sub>	This pin is multiplexed between EMIFA, ATA/CF, and HPI. For HPI, it is the Host Read Write input HR $\overline{\text{W}}$ . This signal is active high for reads and low for writes.
$\overline{\text{EM\_CS2}}$ / HCS	C2	I/O/Z	DV <sub>DD18</sub>	This pin is multiplexed between EMIFA and HPI. In HPI mode, this pin is HPI Active Low Chip Select input $\overline{\text{HCS}}$ .
$\overline{\text{EM\_WE}}$ ( $\overline{\text{WE}}$ ) ( $\overline{\text{IOWR}}$ )/ DIOW/ HDS2	G2	I/O/Z	DV <sub>DD18</sub>	This pin is multiplexed between EMIFA (NAND/SmartMedia/xD), ATA/CF, and HPI. For HPI, it is data strobe 2 input HDS2.
$\overline{\text{EM\_OE}}$ / ( $\overline{\text{RE}}$ ) ( $\overline{\text{IORD}}$ )/ DIOR/ HDS1	H4	I/O/Z	DV <sub>DD18</sub>	This pin is multiplexed between EMIFA (NAND/SmartMedia/xD), ATA/CF, and HPI. For HPI, it is data strobe 1 input HDS1.
EM_WAIT/ (RDY/BSY)/ IORDY/ HRDY	F1	I/O/Z	IPU DV <sub>DD18</sub>	This pin is multiplexed between EMIFA (NAND/SmartMedia/xD), ATA/CF, and HPI. For HPI, it is ready output HRDY.

(1) IPD = Internal pulldown, IPU = Internal pullup. (To pull up a signal to the opposite supply rail, a 1-k $\Omega$  resistor should be used.)

(2) I = Input, O = Output, Z = High impedance, S = Supply voltage, GND = Ground, A = Analog signal

(3) Specifies the operating I/O supply voltage for each signal

**Table 2-26. HPI Terminal Functions (continued)**

SIGNAL		TYPE <sup>(1)</sup>	OTHER <sup>(2)(3)</sup>	DESCRIPTION
NAME	NO.			
EM_D15/ DD15/ HD15	E1	I/O/Z	DV <sub>DD18</sub>	These pins are multiplexed between EMIFA (NAND), ATA/CF, and HPI. In HPI mode, these are HD[15:0] and are multiplexed internally with the HPI address lines.
EM_D14/ DD14/ HD14	H5			
EM_D13/ DD13/ HD13	F2			
EM_D12/ DD12/ HD12	D1			
EM_D11/ DD11/ HD11	G4			
EM_D10/ DD10/ HD10	G5			
EM_D9/ DD9/ HD9	E2			
EM_D8/ DD8/ HD8	F3			
EM_D7/ DD7/ HD7	C1			
EM_D6/ DD6/ HD6	F4			
EM_D5/ DD5/ HD5	D2			
EM_D4/ DD4/ HD4	E4			
EM_D3/ DD3/ HD3	E3			
EM_D2/ DD2/ HD2	F5			
EM_D1/ DD1/ HD1	D3			
EM_D0/ DD0/ HD0	E5			

**Table 2-27. Timer 0, Timer 1, and Timer 2 Terminal Functions**

SIGNAL NAME	NO.	TYPE <sup>(1)</sup>	OTHER <sup>(2)</sup>	DESCRIPTION
<b>Timer 2 and Timer 1</b>				
No external pins. The Timer 2 and Timer 1 peripheral pins are not pinned out as external pins.				
<b>Timer 0</b>				
CLK_OUT1/ TIM_IN/ GPIO49	E19	I/O/Z	DV <sub>DD18</sub>	This pin is multiplexed between the USB clock generator, timer, and GPIO. For Timer0, it is the timer event capture input TIM_IN.

- (1) I = Input, O = Output, Z = High impedance, S = Supply voltage, GND = Ground, A = Analog signal  
(2) Specifies the operating I/O supply voltage for each signal

**Table 2-28. Reserved Terminal Functions**

SIGNAL NAME	NO.	TYPE <sup>(1)</sup>	OTHER <sup>(2)(3)</sup>	DESCRIPTION
<b>RESERVED</b>				
RSV1	A1			Reserved. (Leave unconnected, <b>do not</b> connect to power or ground)
RSV2	A19			Reserved. (Leave unconnected, <b>do not</b> connect to power or ground)
RSV3	W1			Reserved. (Leave unconnected, <b>do not</b> connect to power or ground)
RSV4	W19			Reserved. (Leave unconnected, <b>do not</b> connect to power or ground)
RSV5	D4	I	IPD V <sub>SS</sub>	Reserved. This pin <b>must</b> be tied directly to V <sub>SS</sub> for normal device operation.
RSV6	L3	A O		Reserved. (Leave unconnected, <b>do not</b> connect to power or ground)
RSV7	R8	A		Reserved. (Leave unconnected, <b>do not</b> connect to power or ground)
RSV24	M3	S		Reserved. (Leave unconnected, <b>do not</b> connect to power or ground)

- (1) I = Input, O = Output, Z = High impedance, S = Supply voltage, GND = Ground, A = Analog signal  
(2) IPD = Internal pulldown, IPU = Internal pullup. (To pull up a signal to the opposite supply rail, a 1-k $\Omega$  resistor should be used.)  
(3) Specifies the operating I/O supply voltage for each signal

**Table 2-29. Supply Terminal Functions**

SIGNAL NAME	NO.	TYPE <sup>(1)</sup>	OTHER	DESCRIPTION
<b>SUPPLY VOLTAGE PINS</b>				
DV <sub>DD33</sub>	F10	S		3.3 V I/O supply voltage (see the Power-Supply Decoupling section of this data manual)
	F11			
	F12			
	F13			

- (1) I = Input, O = Output, Z = High impedance, S = Supply voltage, GND = Ground, A = Analog signal

Table 2-29. Supply Terminal Functions (continued)

SIGNAL NAME	NO.	TYPE <sup>(1)</sup>	OTHER	DESCRIPTION
DV <sub>DD18</sub>	N5	S		1.8 V I/O supply voltage (see the Power-Supply Decoupling section of this data manual)
	G15			
	F14			
	J15			
	H14			
	K14			
	M14			
	L13			
	G9			
	F8			
	E7			
	G7			
	J7			
	L7			
	F6			
H6				
K6				
M6				
DV <sub>DDR2</sub>	T5	S		1.8 V DDR2 I/O supply voltage (see the Power-Supply Decoupling section of this data manual)
	P6			
	N7			
	P8			
	N9			
	R9			
	P10			
	N11			
	R11			
	P12			
	N13			
	R13			
	P14			
R15				
CV <sub>DD</sub>	F15	S		1.20 V core supply voltage (see the Power-Supply Decoupling section of this data manual)
	K12			
	M12			
	L11			
	M10			
	L10			
	K10			
	L9			
	L8			
M8				

**Table 2-29. Supply Terminal Functions (continued)**

SIGNAL NAME		NO.	TYPE <sup>(1)</sup>	OTHER	DESCRIPTION
CV <sub>DDSP</sub>		J13	S		1.20 V DSPSS supply voltage (A-513, -594 devices) (see the Power-Supply Decoupling section of this data manual)
		H12			
		H11			
		J11			
		K11			
		J10			
		H10			
		J9			
		K9			
		K8			
	H8				

Table 2-30. Ground Terminal Functions

SIGNAL NAME	NO.	TYPE <sup>(1)</sup>	OTHER	DESCRIPTION
<b>GROUND PINS</b>				
$V_{SS}$	K5	GND		Ground pins
	M5			
	G6			
	J6			
	L6			
	N6			
	R6			
	F7			
	H7			
	K7			
	M7			
	P7			
	R7			
	E8			
	G8			
	J8			
	N8			
	F9			
	H9			
	M9			
	P9			
	G10			
	N10			
	R10			
	G11			
	M11			
	P11			
	G12			
J12				
N12				
L12				
R12				
G13				
H13				
K13				
M13				
P13				
G14				
J14				

(1) I = Input, O = Output, Z = High impedance, S = Supply voltage, GND = Ground, A = Analog signal

**Table 2-30. Ground Terminal Functions (continued)**

SIGNAL NAME		NO.	TYPE <sup>(1)</sup>	OTHER	DESCRIPTION
V <sub>SS</sub>		L14	GND		Ground pins
		N14			
		R14			
		H15			
		K15			
		P15			

## 2.8 Device Support

### 2.8.1 Development Support

TI offers an extensive line of development tools for the SM320DM644x SoC platform, including tools to evaluate the performance of the processors, generate code, develop algorithm implementations, and fully integrate and debug software and hardware modules. The tool's support documentation is electronically available within the Code Composer Studio™ Integrated Development Environment (IDE).

The following products support development of SM320DM644x SoC-based applications:

#### Software Development Tools:

Code Composer Studio™ Integrated Development Environment (IDE): including Editor  
C/C++/Assembly Code Generation, and Debug plus additional development tools

Scalable, Real-Time Foundation Software (DSP/BIOS™), which provides the basic run-time target software needed to support any SoC application.

#### Hardware Development Tools:

Extended Development System (XDS™) Emulator

For a complete listing of development-support tools for the SM320DM644x SoC platform, visit the Texas Instruments web site on the Worldwide Web at <http://www.ti.com> uniform resource locator (URL). For information on pricing and availability, contact the nearest TI field sales office or authorized distributor.

### 2.8.2 Device and Development-Support Tool Nomenclature

To designate the stages in the product development cycle, TI assigns prefixes to the part numbers of all DSP devices and support tools. Each DSP commercial family member has one of three prefixes: TMX, TMP, or TMS (e.g., **TMX320DM6446ZWT**). Texas Instruments recommends two of three possible prefix designators for its support tools: TMDX and TMDS. These prefixes represent evolutionary stages of product development from engineering prototypes (TMX/TMDX) through fully qualified production devices/tools (TMS/TMDS).

Device development evolutionary flow:

**TMX** Experimental device that is not necessarily representative of the final device's electrical specifications.

**TMP** Final silicon die that conforms to the device's electrical specifications but has not completed quality and reliability verification.

**TMS** Fully-qualified production device.

Support tool development evolutionary flow:

**TMDX** Development-support product that has not yet completed Texas Instruments internal qualification testing.

**TMDS** Fully qualified development-support product.

TMX and TMP devices and TMDX development-support tools are shipped against the following disclaimer:

"Developmental product is intended for internal evaluation purposes."

TMS devices and TMDS development-support tools have been characterized fully, and the quality and reliability of the device have been demonstrated fully. TI's standard warranty applies.



Predictions show that prototype devices (TMX or TMP) have a greater failure rate than the standard production devices. Texas Instruments recommends that these devices not be used in any production system because their expected end-use failure rate still is undefined. Only qualified production devices are to be used.

TI device nomenclature also includes a suffix with the device family name. This suffix indicates the package type (for example, ZWT), the temperature range (for example, "Blank" is the commercial temperature range), and the device speed range in megahertz (for example, "Blank" is the default [594-MHz DSP, 297-MHz ARM9]).

Figure 2-6 provides a legend for reading the complete device name for any TMS320DM644x SoC platform member.

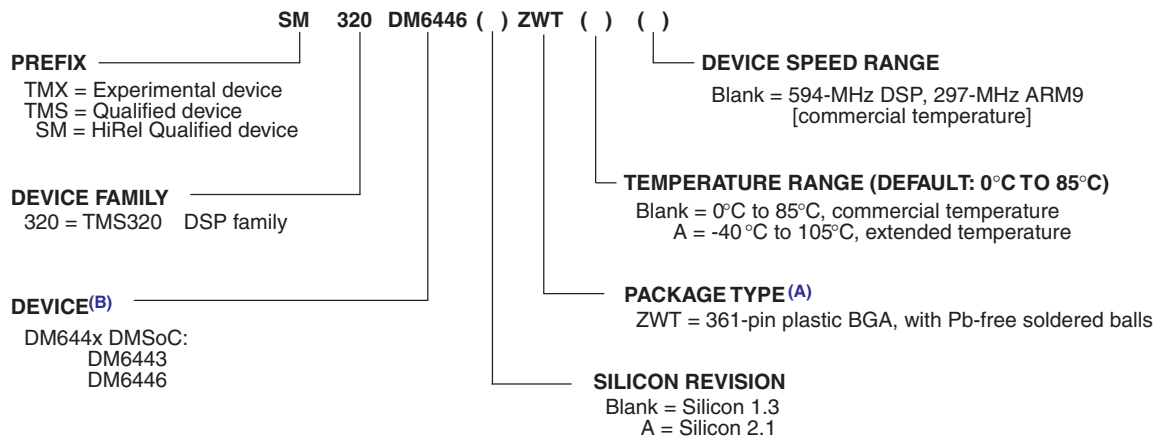

- A. BGA = Ball Grid Array
- B. For actual device part numbers (P/Ns) and ordering information, see the TI website (<http://www.ti.com>).

**Figure 2-6. Device Nomenclature**

## 2.8.3 Documentation Support

### 2.8.3.1 Related Documentation From Texas Instruments

The following documents describe the TMS320DM644x Digital Media System-on-Chip (DMSoC). Copies of these documents are available on the Internet at [www.ti.com](http://www.ti.com). *Tip:* Enter the literature number in the search box provided at [www.ti.com](http://www.ti.com).

The current documentation that describes the DM644x DMSoC, related peripherals, and other technical collateral, is available in the C6000 DSP product folder at: [www.ti.com/c6000](http://www.ti.com/c6000).

**[SPRUE14](#)** ***TMS320DM644x DMSoC ARM Subsystem Reference Guide.*** Describes the ARM subsystem in the TMS320DM644x Digital Media System-on-Chip (DMSoC). The ARM subsystem is designed to give the ARM926EJ-S (ARM9) master control of the device. In general, the ARM is responsible for configuration and control of the device; including the DSP subsystem, the video processing subsystem, and a majority of the peripherals and external memories.

**[SPRUE15](#)** ***TMS320DM644x DMSoC DSP Subsystem Reference Guide.*** Describes the digital signal processor (DSP) subsystem in the TMS320DM644x Digital Media System-on-Chip (DMSoC).

**[SPRUE19](#)** ***TMS320DM644x DMSoC Peripherals Overview Reference Guide.*** Provides an overview and briefly describes the peripherals available on the TMS320DM644x Digital Media System-on-Chip (DMSoC).

**[SPRAA84](#)** ***TMS320C64x to TMS320C64x+ CPU Migration Guide.*** Describes migrating from the Texas Instruments TMS320C64x digital signal processor (DSP) to the TMS320C64x+ DSP. The objective of this document is to indicate differences between the two cores. Functionality in the devices that is identical is not included.

**[SPRU732](#)** ***TMS320C64x/C64x+ DSP CPU and Instruction Set Reference Guide.*** Describes the CPU architecture, pipeline, instruction set, and interrupts for the TMS320C64x and TMS320C64x+ digital signal processors (DSPs) of the TMS320C6000 DSP family. The C64x/C64x+ DSP generation comprises fixed-point devices in the C6000 DSP platform. The C64x+ DSP is an enhancement of the C64x DSP with added functionality and an expanded instruction set.

**[SPRU871](#)** ***TMS320C64x+ DSP Megamodule Reference Guide.*** Describes the TMS320C64x+ digital signal processor (DSP) megamodule. Included is a discussion on the internal direct memory access (IDMA) controller, the interrupt controller, the power-down controller, memory protection, bandwidth management, and the memory and cache.

**[SPRAAA6](#)** ***EDMA v3.0 (EDMA3) Migration Guide for TMS320DM644x DMSoC.*** Describes migrating from the Texas Instruments TMS320C64x digital signal processor (DSP) enhanced direct memory access (EDMA2) to the TMS320DM644x Digital Media System-on-Chip (DMSoC) EDMA3. This document summarizes the key differences between the EDMA3 and the EDMA2 and provides guidance for migrating from EDMA2 to EDMA3.

## 3 Device Configurations

### 3.1 System Module Registers

The system module includes status and control registers required for configuration of the device. Brief descriptions of the various registers are shown in [Table 3-1](#). System Module registers required for device configurations are discussed in the following sections.

**Table 3-1. System Module Register Memory Map**

HEX ADDRESS RANGE	REGISTER ACRONYM	DESCRIPTION
0x01C4 0000	PINMUX0	Pin multiplexing control 0. For details, see <a href="#">Section 3.5.4</a> , PINMUX0 Register Description.
0x01C4 0004	PINMUX1	Pin multiplexing control 1. For details, see <a href="#">Section 3.5.5</a> , PINMUX1 Register Description.
0x01C4 0008	DSPBOOTADDR	Boot address of DSP. For details, see <a href="#">Section 3.3.1.2</a> , DSPBOOTADDR Register Description.
0x01C4 000C	SUSPSRC	Emulator Suspend Source. For details, see <a href="#">Section 3.6</a> , Emulation Control.
0x01C4 0010	INTGEN	ARM/DSP Interrupt Status and Control. For details, see <a href="#">Section 6.7.3</a> , ARM/DSP Communications Interrupts.
0x01C4 0014	BOOTCFG	Device boot configuration. For details, see <a href="#">Section 3.3.1.1</a> , BOOTCFG Register Description.
0x01C4 0018 - 0x01C4 0027	–	Reserved.
0x01C4 0028	JTAGID	JTAGID/Device ID number. For details, see <a href="#">Section 6.25.1</a> , JTAG ID Register Description.
0x01C4 002C	–	Reserved.
0x01C4 0030	HPI_CTL	HPI control. For details, see <a href="#">Section 3.5.6.10</a> , HPI and EMIFA/ATA Pin Multiplexing.
0x01C4 0034	USBPHY_CTL	USB PHY control. For details, see <a href="#">Section 6.15.1</a> , USBPHY_CTL Register Description.
0x01C4 0038	CHP_SHRTSW	Chip shorting switch control. For details, see <a href="#">Section 3.2.1</a> , Power Configurations at Reset.
0x01C4 003C	MSTPRI0	Bus master priority control 0. For details, see <a href="#">Section 3.5.1</a> , Switched Central Resource (SCR) Bus Priorities.
0x01C4 0040	MSTPRI1	Bus master priority control 1. For details, see <a href="#">Section 3.5.1</a> , Switched Central Resource (SCR) Bus Priorities.
0x01C4 0044	VPSS_CLKCTL	VPSS clock control.
0x01C4 0048	VDD3P3V_PWDN	VDD 3.3V I/O powerdown control. For details, see <a href="#">Section 3.2.2</a> , Power Configurations after Reset.
0x01C4 004C	DRRVTPER	Enables access to the DDR2 VTP Register.
0x01C4 0050 - 0x01C4 006F	–	Reserved.

### 3.2 Power Considerations

Global device power domains are controlled by the Power and Sleep Controller, except as shown in the following sections.

#### 3.2.1 Power Configurations at Reset

As described in the *DM6446 Power and Clock Domains* section, the DM6446 has two power domains: Always On and DSP. There is a shorting switch between the two power domains that must be opened when the DSP domain is powered off and closed when the DSP domain is powered on.

The CHP\_SHRTSW register, shown in [Figure 3-1](#), controls the shorting switch between the device always-on and DSP power domains. This switch should be enabled after powering-up the DSP domain.

Setting the DSPPWON bit to '1' closes (enables) the switch and enables the DSP power domain. The default switch value is determined by the DSP\_BT configuration input. If DSP self boot is selected (DSP\_BT=1), the DSP will be powered-up and DSPPWON will be set to a value of '1'. For ARM boot operation (DSP\_BT=0), DSPPWON will be set to the disable value of '0' and must be set by the ARM before the DSP domain power is turned on.

**Note:** Once the DSP power domain is enabled (powered up), it *cannot* be disabled (powered down). Dynamic power down of the DSP is *not* supported on this device.

**Figure 3-1. CHP\_SHRTSW Register**

31	RESERVED	1	0
		DSPPWON	
R-0000 0000 0000 0000 0000 0000 0000 000		R/W-L	

LEGEND: R = Read, W = Write, n = value at reset, L = pin state latched at reset rising

**Table 3-2. CHP\_SHRTSW Register Description**

NAME	DESCRIPTION
DSPPWON	DSP power domain enable. 0 = Shorting switch open 1 = Shorting switch closed

### 3.2.2 Power Configurations after Reset

The VDD3P3V\_PWDN register controls power to the 3.3V I/O buffers for MMC/SD/SDIO and GPIOV33. The 3.3V I/Os are separated into two groups for independent control as shown in [Figure 3-2](#) and described in [Table 3-3](#). By default, these pins are all disabled at reset.

**Figure 3-2. VDD3P3V\_PWDN Register**

31	RESERVED	2	1	0
		IOPWDN1	IOPWDN0	
R-0000 0000 0000 0000 0000 0000 0000 00		R/W-1	R/W-1	

LEGEND: R = Read, W = Write, n = value at reset

**Table 3-3. VDD3P3V\_PWDN Register Description**

NAME	DESCRIPTION
IOPWDN0	GIOV33 I/O Powerdown controls GIOV33[16:0] pins. 0 = I/O buffers powered up 1 = I/O buffers powered down
IOPWDN1	MMC/SD/SDIO I/O Powerdown controls SD_CLK, SD_CMD, SD_DATA[3:0] pins. 0 = I/O buffers powered up 1 = I/O buffers powered down

## 3.3 Bootmode

The device is booted through multiple means: pin states captured at reset, primary bootloaders within internal ROM or EMIFA, and secondary user bootloaders from peripherals or external memories. Boot modes, pin configurations, and register configurations required for booting the device, are described in the following sections.

### 3.3.1 Bootmode Registers

The BOOTCFG and DSPBOOTADDR registers are described in the following sections. At reset, the status of various pins required for proper boot are stored within these registers.

### 3.3.1.1 BOOTCFG Register Description

The BOOTCFG register (located at address 0x01C4 000A) contains the status values of the BTSEL1, BTSEL0, DSP\_BT, EM\_WIDTH, and AEAW[4:0] pins captured at the rising edge of  $\overline{\text{RESET}}$ . The register format is shown in Figure 3-3 and bit field descriptions are shown in Table 3-4. The captured bits are software readable after reset.

Figure 3-3. BOOTCFG Register

31	9	8	7	6	5	4	3	2	1	0
RESERVED				DSP_BT	BTSEL	EM_WIDTH	DAEAW			
R-0000 0000 0000 0000 0000 000				R-L	R-LL	R-L	R-LLLLL			

LEGEND: R = Read; W = Write; L = pin state latched at reset rising; -n = value after reset

Table 3-4. BOOTCFG Register Description

NAME	DESCRIPTION
BTSEL	ARM Boot mode selection pin states (BTSEL1, BTSEL0) captured at the rising edge of $\overline{\text{RESET}}$ . '00' indicates ARM boots from ROM (NAND Flash). '01' indicates that ARM boots from EMIFA (NOR Flash). '10' indicates that ARM boots from ROM (HPI). '11' indicates that ARM boots from ROM (UART0).
DSP_BT	DSP Boot mode selection pin state captured at the rising edge of $\overline{\text{RESET}}$ . '0' sets ARM boot of C64x+. '1' sets C64x+ self boot.
EM_WIDTH	EMIFA data bus width selection pin state captured at the rising edge of $\overline{\text{RESET}}$ . '0' sets EMIFA to 8 bit data bus width '1' sets EMIFA to 16 bit data bus width.
DAEAW	EMIFA address bus width selection pin states (AEAW[4:0]) captured at the rising edge of $\overline{\text{RESET}}$ . This configures EMIFA address pins multiplexed with GPIO. See Table 3-9, Table 3-10, and Table 3-11

### 3.3.1.2 DSPBOOTADDR Register Description

The DSPBOOTADDR register contains the upper 22 bits of the C64x+ DSP reset vector. The register format is shown in Figure 3-4 and bit field descriptions are shown in Table 3-5. DSPBOOTADDR is readable and writable by software after reset.

Figure 3-4. DSPBOOTADDR Registers

31	10	9	0
BOOTADDR[21:0]		RESERVED	
R- 0100 0010 0010 0000 0000 00		R-00 0000 0000	

LEGEND: R/W = Read/Write; R = Read only; -n = value after reset

Table 3-5. DSPBOOTADDR Register Description

NAME	DESCRIPTION
BOOTADDR[21:0]	Upper 22 bits of the C64x+ DSP boot address.

## 3.3.2 ARM Boot

The DM6446 ARM can boot from EMIFA, internal ROM (NAND), UART0, or HPI, as determined by the setting of the BTSEL[1:0] pins. The BTSEL[1:0] pins are read by the ARM ROM Boot Loader (RBL) to further define the ROM boot mode. The ARM boot modes are summarized in Table 3-6.

**Table 3-6. ARM Boot Modes**

BTSEL1	BTSEL0	BOOT MODE	ARM RESET VECTOR	BRIEF DESCRIPTION
0	0	ARM NAND RBL	0x0000 4000	Up to 14 K-bytes secondary boot loader through NAND with up to 2 K-bytes page sizes.
0	1	ARM EMIFA External Boot	0x0200 0000	EMIFA EM_CS2 external memory space.
1	0	ARM HPI RBL	0x0000 4000	Up to 14 K-bytes secondary boot loader through an external host.
1	1	ARM UART RBL	0x0000 4000	Up to 14 K-bytes secondary boot loader through UART0.

When the BTSEL[1:0] pins are set to the ARM EMIFA External Boot ("01"), the ARM immediately begins executing code from the EMIFA EM\_CS2 memory space (0x0200 0000). When the BTSEL[1:0] pins indicate a condition other than the ARM EMIFA External Boot (!01), the RBL begins execution.

ARM NAND Boot mode has the following features:

- Loads a secondary User Boot Loader (UBL) from NAND flash to ARM Internal RAM (AIM) and transfers control to the user software.
- Support for NAND with page sizes up to 2048 bytes.
- Support for error correction when loading UBL
- Support for up to 14KB UBL
- Optional, user selectable, support for use of DMA, I-cache, and PLL enable while loading UBL

ARM UART Boot mode has the following features:

- Loads a secondary UBL via UART0 to AIM and transfers control to the user software.
- Support for up to 14KB UBL

ARM HPI Boot Mode has the following features:

- No support for a full firmware boot. Instead, waits for external host to load a secondary UBL via HPI to AIM and transfers control to the user software.
- Support for up to 14KB UBL.

For further details on the ROM Bootloader, refer to the *ARM Subsystem Users Guide*.

### 3.3.3 DSP Boot

For C64x+ booting, the state of the DSP\_BT pin is sampled at reset. If DSP\_BT is low, the ARM will be the master of C64x+ and control booting (Host Boot mode). If DSP\_BT is high, the C64x+ will boot itself coming out of device reset (Self-Boot mode). [Table 3-7](#) shows a summary of the DSP boot modes.

**Table 3-7. DSP Boot Modes**

DSP_BT	DSP BOOT MODE	ARM BOOT MODE	DSPBOOTADDR REGISTER VALUE	BRIEF DESCRIPTION
0	Host Boot	Internal Boot	Programmable	ARM sets an internal DSP memory location in DSPBOOTADDR register where valid DSP code resides and loads code to this internal DSP memory through DMA prior to releasing DSP reset.
0	Host Boot	External Boot	Programmable	ARM sets an external DSP memory location in DSPBOOTADDR register (EMIFA or DDR2) where valid DSP code resides prior to releasing DSP reset.
1	Self Boot	Any, except HPI	0x4220 0000	Default EMIFA Base Address
1	Host Boot	HPI	Programmable	ARM sets a DSP memory location in the DSPBOOTADDR register. HPI loads code into the DM6446 memory map with the entry point set to the memory location specified in the DSPBOOTADDR register. Once the HPI completes loading the code, the ARM should release the DSP from reset.

### 3.3.3.1 Self-Boot Mode

In self-boot mode, the C64x+ power domain is turned on and the C64x+ DSP is released from reset without ARM intervention. The C64x+ begins execution from the default EMIFA address (0x4220 0000) contained within the DSPBOOTADDR register. The C64x+ begins execution with instruction (L1P) cache enabled.

### 3.4 Configurations at Reset

The following sections give information on configuration settings for the device at reset.

#### 3.4.1 Device Configuration at Device Reset

Table 3-8 shows a summary of device inputs required for booting the ARM and DSP, and configuring EMIFA data and address bus widths for proper operation of the device at the rising edge of the RESET input.

**Table 3-8. Device Configurations (Input Pins Sampled at Reset)**

DEVICE SIGNALS SAMPLED AT RESET	DEVICE SIGNAL NAME AFTER RESET	DESCRIPTION
BTSEL[1:0]	COUT[1:0]	ARM Boot mode selection pins. '00' indicates ARM boots from ROM (NAND Flash). '01' indicates that ARM boots from EMIFA (NOR Flash). '10' indicates that the ARM boots from the HPI (ROM) '11' indicates that ARM boots from ROM (UART0).
DSP_BT	COUT3	DSP Boot mode selection pin. '0' sets ARM boot of C64x+. '1' sets C64x+ self boot.
EM_WIDTH	COUT2	EMIFA data bus width selection pin. '0' sets EMIFA to 8-bit data bus width '1' sets EMIFA to 16-bit data bus width.
AEAW[4:0]	YOUT[4:0]	EMIFA address bus width selection pins for EMIFA address pins multiplexed with GPIO. See Table 3-9, Table 3-10, and Table 3-11 for details.

#### 3.4.2 Peripheral Selection at Device Reset

As briefly mentioned in Table 3-8, the state of the AEAW[4:0] pins captured at reset configures the number of EMIFA address pins required for device boot. These values are stored in the AEAW field of the PINMUX0 register. At reset, this provides proper addressing for external boot. Unused address pins are available for use as GPIO. The register settings are software programmable after reset. Table 3-9, Table 3-10, and Table 3-11 show the AEAW[4:0] bit settings and the corresponding multiplexing for EMIFA address and GPIO pins.

The number of EMIFA address bits enabled is configurable from 0 to 23. EM\_BA[1] and EM\_A[21:0] pins that are not assigned to another peripheral and not enabled as address signals become GPIO pins. The enabled address pins are always contiguous from EM\_BA[1] upwards and address bits cannot be skipped. The exception to this are the EM\_A[2:1] pins. EM\_A[2:1] are usable as the ALE and CLE signals for the NAND Flash mode of EMIFA and are always enabled as EMIFA pins. If an address width of 0 is selected, this still allows a NAND Flash to be accessed. Also, selecting an address width of 2, 3, or 4 (AEAW[4:0] = 00010, 00011, or 00100) always results in 4 address outputs. For these and other address bit enable settings, see Table 3-9, Table 3-10, and Table 3-11.



**Table 3-9. GPIO and EMIFA Multiplexing (Part 1)**

Pin Mux Register AEAW[4:0] Bit Settings							
0000 (default)	00001	00010	00011	00100	00101	00110	00111
GPIO[52]	EM_BA[1]	EM_BA[1]	EM_BA[1]	EM_BA[1]	EM_BA[1]	EM_BA[1]	EM_BA[1]
GPIO[53]	GPIO[53]	EM_A[0]	EM_A[0]	EM_A[0]	EM_A[0]	EM_A[0]	EM_A[0]
EM_A[1]	EM_A[1]	EM_A[1]	EM_A[1]	EM_A[1]	EM_A[1]	EM_A[1]	EM_A[1]
EM_A[2]	EM_A[2]	EM_A[2]	EM_A[2]	EM_A[2]	EM_A[2]	EM_A[2]	EM_A[2]
GPIO[28]	GPIO[28]	GPIO[28]	GPIO[28]	GPIO[28]	EM_A[3]	EM_A[3]	EM_A[3]
GPIO[27]	GPIO[27]	GPIO[27]	GPIO[27]	GPIO[27]	GPIO[27]	EM_A[4]	EM_A[4]
GPIO[26]	GPIO[26]	GPIO[26]	GPIO[26]	GPIO[26]	GPIO[26]	GPIO[26]	EM_A[5]
GPIO[25]	GPIO[25]	GPIO[25]	GPIO[25]	GPIO[25]	GPIO[25]	GPIO[25]	GPIO[25]
GPIO[24]	GPIO[24]	GPIO[24]	GPIO[24]	GPIO[24]	GPIO[24]	GPIO[24]	GPIO[24]
GPIO[23]	GPIO[23]	GPIO[23]	GPIO[23]	GPIO[23]	GPIO[23]	GPIO[23]	GPIO[23]
GPIO[22]	GPIO[22]	GPIO[22]	GPIO[22]	GPIO[22]	GPIO[22]	GPIO[22]	GPIO[22]
GPIO[21]	GPIO[21]	GPIO[21]	GPIO[21]	GPIO[21]	GPIO[21]	GPIO[21]	GPIO[21]
GPIO[20]	GPIO[20]	GPIO[20]	GPIO[20]	GPIO[20]	GPIO[20]	GPIO[20]	GPIO[20]
GPIO[19]	GPIO[19]	GPIO[19]	GPIO[19]	GPIO[19]	GPIO[19]	GPIO[19]	GPIO[19]
GPIO[18]	GPIO[18]	GPIO[18]	GPIO[18]	GPIO[18]	GPIO[18]	GPIO[18]	GPIO[18]
GPIO[17]	GPIO[17]	GPIO[17]	GPIO[17]	GPIO[17]	GPIO[17]	GPIO[17]	GPIO[17]
GPIO[16]	GPIO[16]	GPIO[16]	GPIO[16]	GPIO[16]	GPIO[16]	GPIO[16]	GPIO[16]
GPIO[15]	GPIO[15]	GPIO[15]	GPIO[15]	GPIO[15]	GPIO[15]	GPIO[15]	GPIO[15]
GPIO[14]	GPIO[14]	GPIO[14]	GPIO[14]	GPIO[14]	GPIO[14]	GPIO[14]	GPIO[14]
GPIO[13]	GPIO[13]	GPIO[13]	GPIO[13]	GPIO[13]	GPIO[13]	GPIO[13]	GPIO[13]
GPIO[12]	GPIO[12]	GPIO[12]	GPIO[12]	GPIO[12]	GPIO[12]	GPIO[12]	GPIO[12]
GPIO[11]	GPIO[11]	GPIO[11]	GPIO[11]	GPIO[11]	GPIO[11]	GPIO[11]	GPIO[11]
GPIO[10]	GPIO[10]	GPIO[10]	GPIO[10]	GPIO[10]	GPIO[10]	GPIO[10]	GPIO[10]

**Table 3-10. GPIO and EMIFA Multiplexing (Part 2)**

Pin Mux Register AEAW[4:0] Bit Settings							
01000	01001	01010	01011	01100	01101	01110	01111
EM_BA[1]	EM_BA[1]	EM_BA[1]	EM_BA[1]	EM_BA[1]	EM_BA[1]	EM_BA[1]	EM_BA[1]
EM_A[0]	EM_A[0]	EM_A[0]	EM_A[0]	EM_A[0]	EM_A[0]	EM_A[0]	EM_A[0]
EM_A[1]	EM_A[1]	EM_A[1]	EM_A[1]	EM_A[1]	EM_A[1]	EM_A[1]	EM_A[1]
EM_A[2]	EM_A[2]	EM_A[2]	EM_A[2]	EM_A[2]	EM_A[2]	EM_A[2]	EM_A[2]
EM_A[3]	EM_A[3]	EM_A[3]	EM_A[3]	EM_A[3]	EM_A[3]	EM_A[3]	EM_A[3]
EM_A[4]	EM_A[4]	EM_A[4]	EM_A[4]	EM_A[4]	EM_A[4]	EM_A[4]	EM_A[4]
EM_A[5]	EM_A[5]	EM_A[5]	EM_A[5]	EM_A[5]	EM_A[5]	EM_A[5]	EM_A[5]
EM_A[6]	EM_A[6]	EM_A[6]	EM_A[6]	EM_A[6]	EM_A[6]	EM_A[6]	EM_A[6]
GPIO[24]	EM_A[7]	EM_A[7]	EM_A[7]	EM_A[7]	EM_A[7]	EM_A[7]	EM_A[7]
GPIO[23]	GPIO[23]	EM_A[8]	EM_A[8]	EM_A[8]	EM_A[8]	EM_A[8]	EM_A[8]
GPIO[22]	GPIO[22]	GPIO[22]	EM_A[9]	EM_A[9]	EM_A[9]	EM_A[9]	EM_A[9]
GPIO[21]	GPIO[21]	GPIO[21]	GPIO[21]	EM_A[10]	EM_A[10]	EM_A[10]	EM_A[10]
GPIO[20]	GPIO[20]	GPIO[20]	GPIO[20]	GPIO[20]	EM_A[11]	EM_A[11]	EM_A[11]
GPIO[19]	GPIO[19]	GPIO[19]	GPIO[19]	GPIO[19]	GPIO[19]	EM_A[12]	EM_A[12]
GPIO[18]	GPIO[18]	GPIO[18]	GPIO[18]	GPIO[18]	GPIO[18]	GPIO[18]	EM_A[13]
GPIO[17]	GPIO[17]	GPIO[17]	GPIO[17]	GPIO[17]	GPIO[17]	GPIO[17]	GPIO[17]
GPIO[16]	GPIO[16]	GPIO[16]	GPIO[16]	GPIO[16]	GPIO[16]	GPIO[16]	GPIO[16]
GPIO[15]	GPIO[15]	GPIO[15]	GPIO[15]	GPIO[15]	GPIO[15]	GPIO[15]	GPIO[15]
GPIO[14]	GPIO[14]	GPIO[14]	GPIO[14]	GPIO[14]	GPIO[14]	GPIO[14]	GPIO[14]
GPIO[13]	GPIO[13]	GPIO[13]	GPIO[13]	GPIO[13]	GPIO[13]	GPIO[13]	GPIO[13]
GPIO[12]	GPIO[12]	GPIO[12]	GPIO[12]	GPIO[12]	GPIO[12]	GPIO[12]	GPIO[12]
GPIO[11]	GPIO[11]	GPIO[11]	GPIO[11]	GPIO[11]	GPIO[11]	GPIO[11]	GPIO[11]
GPIO[10]	GPIO[10]	GPIO[10]	GPIO[10]	GPIO[10]	GPIO[10]	GPIO[10]	GPIO[10]

**Table 3-11. GPIO and EMIFA Multiplexing (Part 3)**

Pin Mux Register AEAW[4:0] Bit Settings							
10000	10001	10010	10011	10100	10101	10110	Others
EM_BA[1]	EM_BA[1]	EM_BA[1]	EM_BA[1]	EM_BA[1]	EM_BA[1]	EM_BA[1]	EM_BA[1]
EM_A[0]	EM_A[0]	EM_A[0]	EM_A[0]	EM_A[0]	EM_A[0]	EM_A[0]	EM_A[0]
EM_A[1]	EM_A[1]	EM_A[1]	EM_A[1]	EM_A[1]	EM_A[1]	EM_A[1]	EM_A[1]
EM_A[2]	EM_A[2]	EM_A[2]	EM_A[2]	EM_A[2]	EM_A[2]	EM_A[2]	EM_A[2]
EM_A[3]	EM_A[3]	EM_A[3]	EM_A[3]	EM_A[3]	EM_A[3]	EM_A[3]	EM_A[3]
EM_A[4]	EM_A[4]	EM_A[4]	EM_A[4]	EM_A[4]	EM_A[4]	EM_A[4]	EM_A[4]
EM_A[5]	EM_A[5]	EM_A[5]	EM_A[5]	EM_A[5]	EM_A[5]	EM_A[5]	EM_A[5]
EM_A[6]	EM_A[6]	EM_A[6]	EM_A[6]	EM_A[6]	EM_A[6]	EM_A[6]	EM_A[6]
EM_A[7]	EM_A[7]	EM_A[7]	EM_A[7]	EM_A[7]	EM_A[7]	EM_A[7]	EM_A[7]
EM_A[8]	EM_A[8]	EM_A[8]	EM_A[8]	EM_A[8]	EM_A[8]	EM_A[8]	EM_A[8]
EM_A[9]	EM_A[9]	EM_A[9]	EM_A[9]	EM_A[9]	EM_A[9]	EM_A[9]	EM_A[9]
EM_A[10]	EM_A[10]	EM_A[10]	EM_A[10]	EM_A[10]	EM_A[10]	EM_A[10]	EM_A[10]
EM_A[11]	EM_A[11]	EM_A[11]	EM_A[11]	EM_A[11]	EM_A[11]	EM_A[11]	EM_A[11]
EM_A[12]	EM_A[12]	EM_A[12]	EM_A[12]	EM_A[12]	EM_A[12]	EM_A[12]	EM_A[12]
EM_A[13]	EM_A[13]	EM_A[13]	EM_A[13]	EM_A[13]	EM_A[13]	EM_A[13]	EM_A[13]
EM_A[14]	EM_A[14]	EM_A[14]	EM_A[14]	EM_A[14]	EM_A[14]	EM_A[14]	EM_A[14]
GPIO[16]	EM_A[15]	EM_A[15]	EM_A[15]	EM_A[15]	EM_A[15]	EM_A[15]	EM_A[15]
GPIO[15]	GPIO[15]	EM_A[16]	EM_A[16]	EM_A[16]	EM_A[16]	EM_A[16]	EM_A[16]
GPIO[14]	GPIO[14]	GPIO[14]	EM_A[17]	EM_A[17]	EM_A[17]	EM_A[17]	EM_A[17]
GPIO[13]	GPIO[13]	GPIO[13]	GPIO[13]	EM_A[18]	EM_A[18]	EM_A[18]	EM_A[18]
GPIO[12]	GPIO[12]	GPIO[12]	GPIO[12]	GPIO[12]	EM_A[19]	EM_A[19]	EM_A[19]
GPIO[11]	GPIO[11]	GPIO[11]	GPIO[11]	GPIO[11]	GPIO[11]	EM_A[20]	EM_A[20]
GPIO[10]	GPIO[10]	GPIO[10]	GPIO[10]	GPIO[10]	GPIO[10]	GPIO[10]	EM_A[21]

### 3.5 Configurations After Reset

The following sections give the details on configuring the device after reset.

#### 3.5.1 Switched Central Resource (SCR) Bus Priorities

Prioritization within the switched central resource (SCR) is programmable for each master. The register bit fields and default priority levels for DM6446 bus masters are shown in Table 3-12. The priority levels should be tuned to obtain the best system performance for a particular application. Lower values indicate higher priority. For most masters, their priority values are programmed at the system level by configuring the MSTPRI0 and MSTPRI1 registers. Details on the MSTPRI0/1 registers are shown in Figure 3-5 and Figure 3-6. The C64x+, VPSS, and EDMA masters contain registers that control their own priority values.

**Table 3-12. DM6446 Default Bus Master Priorities**

PRIORITY BIT FIELD	BUS MASTER	DEFAULT PRIORITY LEVEL
VPSSP	VPSS	0 (VPSS PCR Register)
EDMATC0P	EDMATC0	0 (EDMACC QUEPRI Register)
EDMATC1P	EDMATC1	0 (EDMACC QUEPRI Register)
ARM_DMAP	ARM (DMA)	1 (MSTPRI0 Register)
ARM_CFGP	ARM (CFG)	1 (MSTPRI0 Register)
C64X+_DMAP	C64X+ (DMA)	7 (C64x+ MDMAARBE.PRI Register bit field)
C64X+_CFGP	C64X+ (CFG)	1 (MSTPRI0 Register)
EMACP	EMAC	4 (MSTPRI1 Register)
USBP	USB	4 (MSTPRI1 Register)
ATAP	ATA/CF	4 (MSTPRI1 Register)
VLYNQP	VLYNQ	4 (MSTPRI1 Register)
HPIP	HPI	4 (MSTPRI1 Register)

**Figure 3-5. MSTPRI0 Register**

31	RESERVED										19	18	16
											VICPP <sup>(1)</sup>		
R-0000 0000 0000 0											R/W-101		
15	11	10	8	7	6	4	3	2	0				
RESERVED		C64X+_CFGP		RSV	ARM_CFGP		RSV	ARM_DMAP					
R-0000 0		R/W-001		R-0	R/W-001		R-0	R/W-001					

LEGEND: R = Read; W = Write; -n = value after reset

(1) The VICPP bit field is configured by the third-party software. When modifying the MSTPRI0 register a read/modify/write must be performed to preserve the configuration set by the third-party software.

**Figure 3-6. MSTPRI1 Register**

31	RESERVED										23	22	20	19	18	16
											HPIP		RSV	VLYNQP		
R-0000 0000 0											R-100		R-0	R/W-100		
15	14	12	11	10	8	7	6	4	3	2	0					
RSV	ATAP		RSV	USBP		RSV	RESERVED		RSV	EMACP						
R-0	R/W-100		R-0	R/W-100		R-0	R-100		R-0	R/W-100						

LEGEND: R = Read; W = Write; -n = value after reset

### 3.5.2 Multiplexed Pin Configurations

There are numerous multiplexed pins that are shared by more than one peripheral. Some of these pins are configured by external pullup/pulldown resistors only at reset, and others are configured by software. As described in detail in [Section 3.4.1](#) and [Section 3.4.2](#), hardware configurable multiplexed pins are programmed by external pullup/pulldown resistors at reset to set the initial functionality of pins for use by a single peripheral. After reset, software configurable multiplexed pins are programmable through Memory Mapped Registers (MMR) to allow the switching of pin functionalities during run-time. See [Section 3.5.3](#) for more details on the register settings.

A summary of the pin multiplexing is shown in [Table 3-13](#). The EMAC peripheral shares pins with the 3.3V GPIO pins. The VLYNQ pins overlap upper EMIFA address pins resulting in a reduced EMIFA address range as the VLYNQ width is increased. The ATA peripheral shares data lines and some control signals with EMIFA. The ATA DMA pins are multiplexed with UART1. The ASP, UART0/1/2, SPI, I2C, and PWM0/1/2 all default to GPIO pins when not enabled. The VPBE function of the VPSS requires additional pins to implement the RGB888 mode. These are multiplexed with GPIOs.

**Table 3-13. DM6446 Multiplexed Peripheral Pins and Multiplexing Controls**

MULTIPLEXED PERIPHERALS	PRIMARY (DEFAULT) FUNCTION	SECONDARY <sup>(1)</sup> FUNCTION	TERTIARY <sup>(2)</sup> FUNCTION	SECONDARY REGISTER/PIN <sup>(3)</sup> CONTROL	TERTIARY REGISTER/PIN <sup>(3)</sup> CONTROL
EMIFA (NAND), HPI	<b>EMIFA (NAND):</b> EM_A[1] (ALE), EM_A[2] (CLE), EM_CS2, EM_CS3	<b>HPI:</b> HHWIL, HCNTLO, HCS		<b>PinMux0:</b> HPIEN, <b>Pins:</b> BTSEL[1:0] = 10	
EMIFA, HPI, ATA (CF)	<b>EMIFA:</b> EM_D[0:15], EM_BA[0]	<b>ATA (CF):</b> DD[0:15], DA0	<b>HPI:</b> HD[0:15], $\overline{\text{HINT}}$	<b>PinMux0:</b> ATAEN	<b>PinMux0:</b> HPIEN, <b>Pins:</b> BTSEL[1:0] = 10
EMIFA (NAND), HPI, ATA (CF)	<b>EMIFA (NAND):</b> R/W, EM_WAIT (RDY/BSY), EM_OE (RE), EM_WE (WE)	<b>ATA (CF):</b> INTRQ, IORDY, DIOR(IORD), DIOW (IOWR)	<b>HPI:</b> HR/W, HRDY, HDS1, HDS2	<b>PinMux0:</b> ATAEN	<b>PinMux0:</b> HPIEN, <b>Pins:</b> BTSEL[1:0] = 10
VPBE LCD, GPIO	<b>GPIO:</b> GPIO[0]	<b>VPBE:</b> LCD_OE		<b>PinMux0:</b> LOEEN	
VPFE CCD, GPIO	<b>GPIO:</b> GPIO[1]	<b>VPFE:</b> C_WE		<b>PinMux0:</b> CWE	
VPBE RGB888, GPIO	<b>GPIO:</b> GPIO[2]	<b>VPBE:</b> RGB888 G0		<b>PinMux0:</b> RGB888	
VPBE LCD/RGB888, GPIO	<b>GPIO:</b> GPIO[3]	<b>VPBE:</b> RGB888 B0	<b>VPBE:</b> LCD_FIELD	<b>PinMux0:</b> RGB888	<b>PinMux0:</b> LFLDEN
VPFE CCD, VPBE RGB888, GPIO	<b>GPIO:</b> GPIO[4]	<b>VPBE:</b> RGB888 R0	<b>VPFE:</b> CCD_FIELD	<b>PinMux0:</b> RGB888	<b>PinMux0:</b> CFLDEN
VPBE RGB888, GPIO	<b>GPIO:</b> GPIO[5:6, 38]	<b>VPBE:</b> RGB888 G1, B1, R1		<b>PinMux0:</b> RGB888	
EMIFA, VLYNQ, GPIO	<b>GPIO:</b> GPIO[8]	<b>EMIFA:</b> EM_CS5	<b>VLYNQ:</b> VLYNQ_CLOCK	<b>PinMux0:</b> AECS5	<b>PinMux0:</b> VLYNQEN
EMIFA, VLYNQ, GPIO	<b>GPIO:</b> GPIO[9]	<b>EMIFA:</b> EM_CS4	<b>VLYNQ:</b> VLYNQ_SCRUN	<b>PinMux0:</b> AECS4	<b>PinMux0:</b> VLSCREEN
EMIFA, VLYNQ, GPIO	<b>GPIO:</b> GPIO[10:17]	<b>EMIFA:</b> EM_A[21:14]	<b>VLYNQ:</b> VLYNQ_TXD[0:3], VLYNQ_RXD[0:3]	<b>PinMux0:</b> AEAW, <b>Pins:</b> DAAEW[4:0]	<b>PinMux0:</b> VLYNQEN, <b>PinMux0:</b> VLYNQWD[1:0]
EMIFA, GPIO	<b>GPIO:</b> GPIO[18:28]	<b>EMIFA:</b> EM_A[13:3]		<b>PinMux0:</b> AEAW, <b>Pins:</b> DAAEW[4:0]	

- (1) When the Secondary function is enabled, to avoid potential contention, ensure that the Primary (if not GPIO) and Tertiary functions are disabled.
- (2) When the Tertiary function is enabled, to avoid potential contention, ensure that the Primary (if not GPIO), Secondary, and other Tertiary functions are disabled.
- (3) Pin states are sampled at power on reset and written into the register fields.

**Table 3-13. DM6446 Multiplexed Peripheral Pins and Multiplexing Controls (continued)**

MULTIPLEXED PERIPHERALS	PRIMARY (DEFAULT) FUNCTION	SECONDARY <sup>(1)</sup> FUNCTION	TERTIARY <sup>(2)</sup> FUNCTION	SECONDARY REGISTER/PIN <sup>(3)</sup> CONTROL	TERTIARY REGISTER/PIN <sup>(3)</sup> CONTROL
ASP, GPIO	<b>GPIO:</b> GPIO[29:34]	<b>ASP:</b> (all pins) <sup>(4)</sup>		PinMux1:ASP	
UART0, GPIO	<b>GPIO:</b> GPIO[35:36]	<b>UART0:</b> RXD, TXD		PinMux1:UART0	
SPI, GPIO	<b>GPIO:</b> GPIO[37, 39:41]	<b>SPI:</b> SPI_EN0, SPI_CLK, SPI_DI, SPI_DO		PinMux1:SPI	
SPI, ATA, GPIO	<b>GPIO:</b> GPIO[42]	<b>SPI:</b> SPI_EN1	<b>ATA:</b> HDDIR	PinMux1:SPI	PinMux0:HDIREN
I2C, GPIO	<b>GPIO:</b> GPIO[43:44]	<b>I2C:</b> SCL, SDA		PinMux1:I2C	
PWM0, GPIO	<b>GPIO:</b> GPIO[45]	PWM0		PinMux1:PWM0	
PWM1, VPBE (RGB666/RGB888), GPIO	<b>GPIO:</b> GPIO[46]	<b>VPBE:</b> RGB666/RGB888 R2	<b>PWM1:</b> PWM1	PinMux0:RGB666/ PinMux0:RGB888	PinMux1:PWM1
PWM2, VPBE (RGB666/RGB888), GPIO	<b>GPIO:</b> GPIO[47]	<b>VPBE:</b> RGB666/RGB888 B2	<b>PWM2:</b> PWM2	PinMux0:RGB666/ PinMux0:RGB888	PinMux1:PWM2
ClockOut0, GPIO	<b>GPIO:</b> GPIO[48]	CLK_OUT0		PinMux1:CLK0	
ClockOut1, TIMER0, GPIO	<b>GPIO:</b> GPIO[49]	CLK_OUT1	<b>TIMER0:</b> TIM_IN	PinMux1:CLK1	PinMux1:TIM_IN
ATA, GPIO	<b>GPIO:</b> GPIO[50:51]	<b>ATA:</b> ATA_CS0, ATA_CS1		PinMux0:ATAEN	
EMIFA, GPIO, ATA (CF)	<b>GPIO:</b> GPIO[52]	<b>EMIFA:</b> EM_BA[1]	<b>ATA (CF):</b> DA1	PinMux0:AEAW[4:0], Pins:DAAEW[4:0]	PinMux0:ATAEN
EMIFA, HPI, ATA (CF), GPIO	<b>GPIO:</b> GPIO[53]	<b>EMIFA:</b> EM_A[0]	<b>ATA (CF):</b> DA2/ <b>HPI:</b> HCNTL1	PinMux0:AEAW[4:0], Pins:DAAEW[4:0]	PinMux0:ATAEN, PinMux0:HPIEN, Pins:BTSEL[1:0] = 10
EMAC, GPIO3V	<b>GPIO:</b> GPIO3V[0:13]	<b>EMAC:</b> (all pins, except CRS) <sup>(4)</sup>		PinMux0:EMACEN	
EMAC, MDIO, GPIO3V	<b>GPIO:</b> GPIO3V[14:16]	<b>EMAC:</b> CRS, <b>MDIO:</b> MDIO, MDCLK		PinMux0:EMACEN	
UART1, ATA (CF)	N/A	<b>ATA (CF):</b> DMACK, DMARQ	<b>UART1:</b> TXD, RXD	PinMux0:ATAEN	PinMux1:UART1
UART2, VPFE	<b>VPFE:</b> CI[7:6]/ CCD_DATA[15:14]	<b>UART2:</b> UART_RXD2, UART_TXD2		PinMux1:UART2	
UART2, VPFE	<b>VPFE:</b> CI[5:4]/ CCD_DATA[13:12]	<b>UART2:</b> UART_CTS2, UART_RTS2		PinMux1:UART2, PinMux1:U2FLO	

(4) See the Terminal Functions section for pin details.

### 3.5.3 Peripheral Selection After Device Reset

After device reset, the PINMUX0 and PINMUX1 registers are software programmable to allow multiplexing of shared device pins between peripherals, as given in the Terminal Functions section. [Section 3.5.4](#), [Section 3.5.5](#), and [Section 3.5.6](#) identify the register settings necessary to configure specific multiplexed functions and show the primary (default) function after reset.

### 3.5.4 PINMUX0 Register Description

The PINMUX0 pin multiplexing register controls which peripheral is given ownership over shared pins among EMAC, CCD, LCD, RGB888, RGB666, ATA, VLYNQ, EMIFA, HPI, and GPIO peripherals. The register format is shown in Figure 3-7 and bit field descriptions are given in Table 3-14. More details on the PINMUX0 pin muxing fields are given in Section 3.5.6. A value of '1' enables the secondary or tertiary pin function.

Figure 3-7. PINMUX0 Register<sup>(1)</sup>

31	30	29	28	27	26	25	24	23	22	21	18	17	16
EMACEN	Rsvd	HPIEN	Rsvd	CFLDEN	CWE	LFLDEN	LOEEN	RGB888	RGB666	Reserved	ATAEN	HDIREN	
R/W-0	R/W-0	R/W-D	R-0	R/W-0	R/W-0	R/W-0	R/W-0	R/W-0	R/W-0	R-0000	R/W-0	R/W-0	
15	14	13	12	11	10	9				5	4		0
VLYNQEN	VLSCREN	VLYNQWD	AECS5	AECS4	Reserved					AEAW			
R/W-0	R/W-0	R/W-00	R/W-0	R/W-0	R-00000					R/W-LLLL			

LEGEND: R = Read; W = Write; L = pin state latched at reset rising edge; D = derived from pin states; -n = value after reset

(1) For proper DM6446 device operation, **always** write a value of '0' to RSV bits 30 and 29

Table 3-14. PINMUX0 Register Description

Name	Description
EMACEN	Enable EMAC and MDIO function on default GPIO3V[0:16] pins.
HPIEN	Enable HPI module pins. Default value is derived from BTSEL[1:0] configuration inputs. HPIEN is 1 when the BTSEL[1:0] = 10 for non-secure devices only. HPIEN default state is always 0 for secure devices.
CFLDEN	Enable CCD C_FIELD function on default GPIO[4] pin
CWE	Enable CCD C_WE function on default GPIO[1] pin
LFLDEN	Enable LCD_FIELD function on default GPIO[3] pin
LOEEN	Enable LCD_OE function on default GPIO[0] pin
RGB888	Enable VPBE RGB888 function on default GPIO[2:6, 46:47] pins
RGB666	Enable VPBE RGB666 function on default GPIO[46:47] pins
ATAEN	Enable ATA function on default EMIFA and GPIO[52:53] pins and shared UART1 pins
HDIREN	Enable HDDIR function on default GPIO[42] pin
VLYNQEN	Enable VLYNQ function on default GPIO[9,10:17] pins
VLSCREN	Enable VLYNQ SCRUN function on default GPIO[9] pin
VLYNQWD	VLYNQ data width selection. This expands the VLYNQ TXD[0:3] and RXD[0:3] functions on default GPIO[10:17] pins.
AECS5	Enable EMIFA EM_CS5 function on GPIO[8]
AECS4	Enable EMIFA EM_CS4 function on GPIO[9]
AEAW	EMIFA address width selection. Default value is latched at reset from AEAW[4:0] configuration input pins. This enables EMIF address function on default GPIO[10:28] pins.

### 3.5.5 PINMUX1 Register Description

The PINMUX1 pin multiplexing register controls which peripheral is given ownership over shared pins among Timer, PLL, ASP, SPI, I2C, PWM, and UART peripherals. The register format is shown in Figure 3-8 and bit field descriptions are given in Table 3-15. More details on the PINMUX1 pin muxing fields are given in Section 3.5.6. A value of "1" enables the secondary or tertiary pin function.

Figure 3-8. PINMUX1 Register<sup>(1)</sup>

31											19	18	17	16
Reserved											TIMIN	CLK1	CLK0	
R-0000 0000 0000 0											R/W-0	R/W-0	R/W-0	
15	11	10	9	8	7	6	5	4	3	2	1	0		
Reserved		ASP	Rsvd	SPI	I2C	PWM2	PWM1	PWM0	U2FLO	UART2	UART1	UART0		
R-0000 0		R/W-0	R/W-0	R/W-0	R/W-0	R/W-0	R/W-0	R/W-0	R/W-0	R/W-0	R/W-0	R/W-0		

LEGEND: R/W = Read/Write; R = Read only; -n = value after reset

(1) For proper DM6446 device operation, **always** write a value of '0' to RSV bit 9.

Table 3-15. PINMUX1 Register Description

Name	Description
TIMIN	Enable TIM_IN function on default GPIO[49] pin
CLK1	Enable CLK_OUT1 function on default GPIO[49] pin
CLK0	Enable CLK_OUT0 function on default GPIO[48] pin
ASP	Enable ASP function on default GPIO[29:34] pins
SPI	Enable SPI function on default GPIO[37,39:42] pins
I2C	Enable I2C function on default GPIO[43:44] pins
PWM2	Enable PWM2 function on default GPIO[47] pin
PWM1	Enable PWM1 function on default GPIO[46] pin
PWM0	Enable PWM0 function on default GPIO[45] pin
U2FLO	Enable UART2 flow control function on default VPFE CI[5:4]/CCD_DATA[13:12] pins
UART2	Enable UART2 function on default VPFE CI[7:6]/CCD_DATA[15:14] pins
UART1	Enable UART1 function on shared ATA (CF) DMACK, DMARQ pins
UART0	Enable UART0 function on default GPIO[35:36] pins

### 3.5.6 Pin Multiplexing Register Field Details

The bit fields for various pin multiplexing options within the PINMUX0 and PINMUX1 registers are described in the following sections.

#### 3.5.6.1 EMAC and GPIO3V Pin Multiplexing

The EMAC pin functions are selected as shown in [Table 3-16](#). The functionality for each of the individual pins affected by the PINMUX0 field settings is given in [Table 3-17](#).

Table 3-16. EMAC and GPIO3V Pin Multiplexing Control

EMACEN	PIN FUNCTIONALITY SELECTED
0	GPIO3V
1	EMAC

Table 3-17. EMAC and GPIO3V Multiplexed Pins

GPIO	EMAC
GPIO3V[0]	TXEN
GPIO3V[1]	TXCLK
GPIO3V[2]	COL



GPIO3V[3]	TXD[0]
GPIO3V[4]	TXD[1]
GPIO3V[5]	TXD[2]
GPIO3V[6]	TXD[3]
GPIO3V[7]	RXD[0]
GPIO3V[8]	RXD[1]
GPIO3V[9]	RXD[2]
GPIO3V[10]	RXD[3]
GPIO3V[11]	RXCLK
GPIO3V[12]	RXDV
GPIO3V[13]	RXER
GPIO3V[14]	CRS
GPIO3V[15]	MDIO
GPIO3V[16]	MDCLK

### 3.5.6.2 VPFE (CCD), VPBE (LCD), and GPIO Pin Multiplexing

The CCD and LCD controllers in the VPSS require multiplex control bit settings for certain modes of operation. Bits within the PinMux0 register, which select between the CCD or LCD control signal function and GPIO, are summarized in [Table 3-18](#).

**Table 3-18. VPFE (CCD), VPBE (LCD), and GPIO Pin Multiplexing**

PINMUX0 REGISTER FIELDS				MULTIPLEXED PINS			
CFLDEN	LFLDEN	CWE	LOEEN	C_FIELD/ R0/ GPIO[4]	LCD_FIELD/ B0/ GPIO[3]	C_WE/ GPIO[1]	LCD_OE/ GPIO[0]
-	-	-	0	-	-	-	GPIO[0]
-	-	-	1	-	-	-	LCD_OE
-	-	0	-	-	-	GPIO[1]	-
-	-	1	-	-	-	C_WE	-
-	0	-	-	-	B0/GPIO[3] <sup>(1)</sup>	-	-
-	1	-	-	-	LCD_FIELD	-	-
0	-	-	-	R0/GPIO[4] <sup>(1)</sup>	-	-	-
1	-	-	-	C_FIELD	-	-	-

(1) Depends on RGB888 bit setting, see [Table 3-19](#)

### 3.5.6.3 VPBE (RGB666 and RGB888) and GPIO Pin Multiplexing

Use of the RGB666 and RGB888 modes of the VPBE requires enabling RGB pins as shown in [Table 3-19](#) and [Table 3-20](#). Enabling PWM2, PWM1, CCD, and LCD functionality overrides the RGB modes. RGB666 interface pin functionality requires setting the RGB666 PINMUX0 Register bit field to '1' and PINMUX1 Register bit fields PWM2 and PWM1 to '0'. Proper RGB888 interface operation requires setting PINMUX0 Register bit field RGB888 to '1' and bit fields PWM2, PWM1, CFLDEN, and LFLDEN must be set to '0'.

**Table 3-19. VPBE (RGB666, RGB888, and LCD), VPFE (CCD), and GPIO Pin Multiplexing**

PINMUX0 AND PINMUX1 REGISTER BIT FIELDS						MULTIPLEXED PINS			
RGB888	RGB666	PWM2	PWM1	CFLDEN	LFLDEN	PWM2/ B2/ GPIO[47]	PWM1/ R2/ GPIO[46]	C_FIELD/ R0/ GPIO[4]	LCD_FIELD/ B0/ GPIO[3]
0	0	0	0	0	0	GPIO[47]	GPIO[46]	GPIO[4]	GPIO[3]
-	-	-	-	-	1	-	-	-	LCD_FIELD
-	-	-	-	1	-	-	-	C_FIELD	-
-	-	-	1	-	-	-	PWM1	-	-
-	-	1	-	-	-	PWM2	-	-	-

0	1	0	0	0	0	B2	R2	GPIO[4]	GPIO[3]
1	-	0	0	0	0	B2	R2	R0	B0

**Table 3-20. VPBE (RGB666, RGB888, and LCD) and GPIO Pin Multiplexing**

PINMUX0 AND PINMUX1 REGISTER BIT FIELDS					MULTIPLEXED PINS			
RGB888	PWM2	PWM1	CFLDEN	LFLDEN	R1/ GPIO[38]	B1/ GPIO[6]	G1/ GPIO[5]	G0/ GPIO[2]
0	0	0	0	0	GPIO[38]	GPIO[6]	GPIO[5]	GPIO[2]
1	0	0	0	0	R1	B1	G1	G0

**3.5.6.4 ATA, EMIFA, UART1, SPI, and GPIO Pin Multiplexing**

The ATA peripheral shares pins with the EMIFA and UART1 as seen in [Table 3-21](#). If ATA pin functionality is enabled by setting the ATAEN bit field, the ATA module will drive the EMIFA data and control pins. Enabling UART1 disables the use of the ATA DMARQ and DMACK signals and thus only allows the ATA module to use PIO mode. The ATA HDDIR buffer direction control bit field works in conjunction with the HDIREN enable bit field to allow the ATA pins to still be used as a GPIO or SPI\_EN1 if the buffer is not being used (i.e. for Compact Flash). This multiplexing is shown in [Table 3-22](#). When ATAEN=0 and HDIREN=1 it indicates that the ATA interface has been disabled so that the EMIFA can be used, but the ATA buffers are still present. HDDIR is driven low in this situation to ensure that the ATA buffers drive away from DM644X and don't cause bus contention with the EMIFA. Note that switching between EMIFA and ATA (clearing or setting ATAEN) must be carefully performed to prevent bus contention. Since the ATA device can be a bus master, software must ensure that all outstanding DMA requests have completed before clearing the ATAEN bit.

**Table 3-21. ATA, EMIFA, and GPIO Pin Multiplexing Control<sup>(1)</sup>**

PINMUX0 REGISTER BIT FIELD	MULTIPLEXED PINS									
	ATAEN	GPIO[50]/ ATA_CS0	GPIO[51]/ ATA_CS1	EM_R $\bar{W}$ / INTRQ	EM_BA[0]/ ATA0	EM_WAIT/ IORDY	$\bar{D}$ IOR/ EM_OE	$\bar{D}$ IOW/ EM_WE	EM_BA[1]/ GPIO[52]/ ATA1	EM_A[0]/ GPIO[53]/ ATA2
0	GPIO[50]	GPIO[51]	EM_R $\bar{W}$	EM_BA[0]	EM_WAIT	$\bar{E}$ M_OE	$\bar{E}$ M_WE	EM_BA[1]/ GPIO[52] <sup>(2)</sup>	EM_A[0]/ GPIO[53] <sup>(2)</sup>	EM_D[15:0]
1	ATA_CS0	ATA_CS1	INTRQ	ATA0	IORDY	DIOR	DIOW	ATA1	ATA2	DD[15:0]

(1) This table assumes that the HPIEN bit in the PINMUX0 register is "0".  
 (2) This pin shares GPIO functionality set by AEA[W[4:0] as shown in [Table 3-9](#).

**Table 3-22. ATA, EMIFA, UART1, SPI, and GPIO Pin Multiplexing**

PINMUX0 AND PINMUX1 REGISTER BIT FIELDS				MULTIPLEXED PINS		
ATAEN	UART1	HDIREN	SPI	UART_TXD1/ DMACK	UART_RXD1/ DMARQ	SPI_EN1/ HDDIR/ GPIO[42]
0	0	0	0	DMACK	DMARQ	GPIO[42]
0	0	0	1	DMACK	DMARQ	SPI_EN1
0	0	1	-	DMACK	DMARQ	Driven Low
0	1	0	0	UART_TXD1	UART_RXD1	GPIO[42]
0	1	0	1	UART_TXD1	UART_RXD1	SPI_EN1
0	1	1	-	UART_TXD1	UART_RXD1	Driven Low
1	0	0	0	DMACK	DMARQ	GPIO[42]x
1	0	0	1	DMACK	DMARQ	SPI_EN1x
1	0	1	-	DMACK	DMARQ	HDDIR
1	1	0	0	UART_TXD1	UART_RXD1	GPIO[42]x
1	1	0	1	UART_TXD1	UART_RXD1	SPI_EN1x
1	1	1	-	UART_TXD1	UART_RXD1	HDDIR

### 3.5.6.5 VLYNQ, EMIFA, and GPIO Pin Multiplexing

Table 3-23 and Table 3-24 show the VLYNQ pin control and multiplexing. If VLYNQ is disabled (VLYNQEN=0), the AECS5 and AECS4 bits select between the GPIO[8] / EMIFA EM\_CS5 and GPIO[9] / EMIFA EM\_CS4 functions, and the AEAW field determines the partitioning between GPIO and the upper EMIFA address pins. If VLYNQ is enabled (VLYNQEN=1), VLYNQ\_CLOCK, VLYNQ\_TXD0, and VLYNQ\_RXD0 are always selected. The VLYNQ\_SCRUN function is only enabled if VLYNQEN=1 and VLSCREN=1 (VLSCREN overrides AECS4). The remaining VLYNQ TX/RX pins are selected based on the VLYNQWD value. Unselected VLYNQ TX/RX pins will function as either GPIO or EMIFA address based on the AEAW value.

**Table 3-23. VLYNQ Control, EMIFA, and GPIO Pin Multiplexing**

PINMUX0 REGISTER BIT FIELDS				MULTIPLEXED PINS	
VLYNQEN	VLSCREN	AECS5	AECS4	EM_CS5/ GPIO[8]/ VLYNQ_CLOCK	EM_CS4/ GPIO[9]/ VLYNQ_SCRUN
0	-	0	0	GPIO[8]	GPIO[9]
0	-	0	1	GPIO[8]	EM_CS4
0	-	1	0	EM_CS5	GPIO[9]
0	-	1	1	EM_CS5	EM_CS4
1	0	-	0	VLYNQ_CLOCK	GPIO[9]
1	0	-	1	VLYNQ_CLOCK	EM_CS4
1	1	-	-	VLYNQ_CLOCK	VLYNQ_SCRUN

**Table 3-24. VLYNQ Data, EMIFA, and GPIO Pin Multiplexing**

PINMUX0 REGISTER BIT FIELDS		MULTIPLEXED PINS							
VLYNQEN	VLYNQWD	EM_A[21]/ GPIO[10]/ VL_TXD0	EM_A[20]/ GPIO[11]/ VL_RXD0	EM_A[19]/ GPIO[12]/ VL_TXD1	EM_A[18]/ GPIO[13]/ VL_RXD1	EM_A[17]/ GPIO[14]/ VL_TXD2	EM_A[16]/ GPIO[15]/ VL_RXD2	EM_A[15]/ GPIO[16]/ VL_TXD3	EM_A[14]/ GPIO[17]/ VL_RXD3
0	-	EM_A[21]/ GPIO[10] <sup>(1)</sup>	EM_A[20]/ GPIO[11] <sup>(1)</sup>	EM_A[19]/ GPIO[12] <sup>(1)</sup>	EM_A[18]/ GPIO[13] <sup>(1)</sup>	EM_A[17]/ GPIO[14] <sup>(1)</sup>	EM_A[16]/ GPIO[15] <sup>(1)</sup>	EM_A[15]/ GPIO[16] <sup>(1)</sup>	EM_A[14]/ GPIO[17] <sup>(1)</sup>
1	00	VL_TXD0	VLRXD0	EM_A[19]/ GPIO[12] <sup>(1)</sup>	EM_A[18]/ GPIO[13] <sup>(1)</sup>	EM_A[17]/ GPIO[14] <sup>(1)</sup>	EM_A[16]/ GPIO[15] <sup>(1)</sup>	EM_A[15]/ GPIO[16] <sup>(1)</sup>	EM_A[14]/ GPIO[17] <sup>(1)</sup>
1	01	VL_TXD0	VLRXD0	VL_TXD1	VLRXD1	EM_A[17]/ GPIO[14] <sup>(1)</sup>	EM_A[16]/ GPIO[15] <sup>(1)</sup>	EM_A[15]/ GPIO[16] <sup>(1)</sup>	EM_A[14]/ GPIO[17] <sup>(1)</sup>
1	10	VL_TXD0	VLRXD0	VL_TXD1	VLRXD1	VL_TXD2	VLRXD2	EM_A[15]/ GPIO[16] <sup>(1)</sup>	EM_A[14]/ GPIO[17] <sup>(1)</sup>
1	11	VL_TXD0	VLRXD0	VL_TXD1	VLRXD1	VL_TXD2	VLRXD2	VL_TXD3	VLRXD3

(1) This pin shares GPIO functionality set by AEAW[4:0] as shown in [Table 3-9](#).

### 3.5.6.6 Timer0 Input, CLK\_OUT1, and GPIO Pin Multiplexing

The multiplexing of the CLK\_OUT1 and Timer0 Input (Timer 0 only) functions is shown in [Table 3-25](#).

**Table 3-25. Timer0 Input, CLK\_OUT1, and GPIO Pin Multiplexing**

PINMUX1 REGISTER BIT FIELDS		MULTIPLEXED PINS
TIMIN	CLK1	CLK_OUT1/ TIM_IN/ GPIO[49]
0	0	GPIO[49]
0	1	CLK_OUT1
1	-	TIM_IN

### 3.5.6.7 ASP, SPI, I2C, ATA, and GPIO Pin Multiplexing

When the ASP, SPI, or I2C serial port functions are not selected, their pins may be used as GPIOs as seen in [Table 3-26](#), [Table 3-27](#), and [Table 3-28](#). The SPI\_EN1 pin can also function as the HDDIR buffer control when ATAEN is selected and the HDIREN bit is set.

**Table 3-26. ASP and GPIO Pin Multiplexing**

PINMUX1 REGISTER BIT FIELD	MULTIPLEXED PINS					
ASP	CLKX/ GPIO[29]	CLKR/ GPIO[30]	FSX/ GPIO[31]	FSR/ GPIO[32]	DX/ GPIO[33]	DR/ GPIO[34]
0	GPIO[29]	GPIO[30]	GPIO[31]	GPIO[32]	GPIO[33]	GPIO[34]
1	CLKX	CLKR	FSX	FSR	DX	DR

**Table 3-27. SPI and GPIO Pin Multiplexing**

PINMUX0 AND PINMUX1 REGISTER BIT FIELDS			MULTIPLEXED PINS				
SPI	ATAEN	HDIREN	SP_EN1/ HDDIR/ GPIO[42]	SPI_DO/ GPIO[41]	SPI_DI/ GPIO[40]	SPI_CLK/ GPIO[39]	SPI_EN0/ GPIO[37]
0	0	0	GPIO[42]	GPIO[41]	GPIO[40]	GPIO[39]	GPIO[37]
0	0	1	Driven Low	GPIO[41]	GPIO[40]	GPIO[39]	GPIO[37]
0	1	0	GPIO[42]	GPIO[41]	GPIO[40]	GPIO[39]	GPIO[37]
0	1	1	HDDIR	GPIO[41]	GPIO[40]	GPIO[39]	GPIO[37]
1	0	0	SP_EN1	SPI_DO	SPI_DI	SPI_CLK	SPI_EN0
1	0	1	Driven Low	SPI_DO	SPI_DI	SPI_CLK	SPI_EN0
1	1	0	SP_EN1	SPI_DO	SPI_DI	SPI_CLK	SPI_EN0
1	1	1	HDDIR	SPI_DO	SPI_DI	SPI_CLK	SPI_EN0

**Table 3-28. I2C and GPIO Pin Multiplexing**

PINMUX1 REGISTER BIT FIELD	MULTIPLEXED PINS	
I2C	I2C_CLK/ GPIO[43]	I2C_DATA/ GPIO[44]
0	GPIO[43]	GPIO[44]
1	I2C_CLK	I2C_DATA

### 3.5.6.8 PWM, RGB888, and GPIO Pin Multiplexing

Table 3-29 shows the PWM0/1/2 pin multiplexing. Each PWM output is independently controlled by its own enable bit. The PWM function has priority over RGB888 muxing (see Section 3.5.6.3).

**Table 3-29. PWM0/1/2, RGB888, and GPIO Pin Multiplexing**

PINMUX1 REGISTER BIT FIELDS				MULTIPLEXED PINS		
PWM2	PWM1	PWM0	RGB888	PWM2/ B2/ GPIO[47]	PWM1/ R2/ GPIO[46]	PWM0/ GPIO[45]
0	0	0	0	GPIO[47]	GPIO[46]	GPIO[45]
0	0	0	1	B2	R2	GPIO[45]
-	-	1	-	-	-	PWM0
-	1	-	-	-	PWM1	-
1	-	-	-	PWM2	-	-

### 3.5.6.9 UART, VPFE, ATA, and GPIO Pin Multiplexing

Each UART has independent pin multiplexing control bits in the PINMUX1 register. The UART2 peripheral may be used with or without the flow control signals. Table 3-30 shows how UART2 selection reduces the width of the VPFE interface.

Setting the UART1 bit enables UART1 transmit and receive pin functionality. Since these are shared with the ATA DMA handshake signals, enabling UART1 effectively disables the ATA DMA mode. However, ATA PIO mode is still supported with UART1 enabled. This is shown in Table 3-31. If the ATA module is not enabled, the pins are always configured for use by UART1.

**Table 3-30. UART2, VPFE, and GPIO Pin Multiplexing**

PINMUX1 REGISTER BIT FIELDS		MULTIPLEXED PINS			
UART2	U2FLO	CCD[15]/ CI[7]/ UART_RXD2	CCD[14]/ CI[6]/ UART_TXD2	CCD[13]/ CI[5]/ UART_CTS2	CCD[12]/ CI[4]/ UART_RTS2
0	-	CCD[15]/ CI[7] <sup>(1)</sup>	CCD[14]/ CI[6] <sup>(1)</sup>	CCD[13]/ CI[5] <sup>(1)</sup>	CCD[12]/ CI[4] <sup>(1)</sup>
1	0	UART_RXD2	UART_TXD2	CCD[13]/ CI[5] <sup>(1)</sup>	CCD[12]/ CI[4] <sup>(1)</sup>
1	1	UART_RXD2	UART_TXD2	UART_CTS2	UART_RTS2

(1) Functionality set by VPFE operating mode.

**Table 3-31. UART1 and ATA Pin Multiplexing**

PINMUX0 AND PINMUX1 REGISTER BIT FIELDS		MULTIPLEXED PINS	
ATAEN	UART1	UART_TXD1/ DMACK	UART_RXD1/ DMARQ
0	-	UART_TXD1	UART_RXD1
1	0	DMACK	DMARQ
1	1	UART_TXD1	UART_RXD1

As [Table 3-32](#) shows, the UART0 pins are configurable for either UART0 transmit and receive data functions or for GPIO.

**Table 3-32. UART0 and GPIO Pin Multiplexing**

PINMUX1 REGISTER BIT FIELD	MULTIPLEXED PINS	
UART0	UART_TXD0/ GPIO[36]	UART_RXD0/ GPIO[35]
0	GPIO[36]	GPIO[35]
1	UART_TXD0	UART_RXD0

### 3.5.6.10 HPI and EMIFA/ATA Pin Multiplexing

When the HPIEN bit is set, the HPI module is given control of most of the EMIFA/ATA control pins as well as the EMIFA/ATA data bus. [Table 3-33](#) shows which pins the HPI controls. HPIEN is set to 1 when the state of the BTSEL[1:0] pins = 10 is latched at the rising edge of reset. Also, this bit can be manipulated after reset by software. When the ATAEN bit is set and HPIEN is 0, the ATA mode of operation for pins shared with the HPI is available. EMIFA mode functionality for the shared HPI pins is set when both HPIEN and ATAEN are '0'.

**Table 3-33. HPI and EMIFA/ATA Pin Multiplexing**

PINMUX0 REGISTER BIT FIELDS		MULTIPLEXED PINS									
HPI EN	ATA EN	HCS/ EM_CS2	HHWIL/ EM_A[1]	HR $\bar{W}$ / INTRQ/ EM_R $\bar{W}$	HRD $\bar{Y}$ / EM_WAIT/ IORD $\bar{Y}$	HDS1/ DIOR/ EM_OE	HDS2/ DIOW/ EM_WE	HCNTLA/ EM_A[2]	HCNTLB/ ATA2/ EM_A[0]	HINT/ ATA0/ EM_BA[0]	HD[15:0]/ DD[15:0]/ EM_D[15:0]
0	0	EM_CS2	EM_A[1] <sup>(1)</sup>	EM_R $\bar{W}$	EM_WAIT	EM_OE	EM_WE	EM_A[2] <sup>(1)</sup>	EM_A[0] <sup>(1)</sup>	EM_BA[0]	EM_D[15:0]
0	1	EM_CS2	EM_A[1] <sup>(1)</sup>	INTRQ	IORD $\bar{Y}$	DIOR	DIOW	EM_A[2] <sup>(1)</sup>	EM_A[0] <sup>(1)</sup>	ATA0	DD[15:0]
1	-	HCS	HHWIL	HR $\bar{W}$	HRD $\bar{Y}$	HDS1	HDS2	HCNTLA	HCNTLB	HINT	HD[15:0]

(1) This pin shares GPIO functionality and is set by AEA[4:0] as shown in [Table 3-12](#), [Table 3-13](#), and [Table 3-14](#).

### 3.6 Emulation Control

The flexibility of the DM644x architecture allows either the ARM or DSP to control the various peripherals (setup registers, service interrupts, etc.). While this assignment is purely a matter of software convention, during an emulation halt it is necessary for the device to know which peripherals are associated with the halting processor so that only those modules receive the suspend signal. This allows peripherals associated with the other (unhalted) processor to continue normal operation. The SUSPSRC register indicates the emulation suspend source for those peripherals which support emulation suspend. The SUSPSRC register format is shown in Figure 3-9. Brief details on the peripherals which correspond to the register bits is given in Table 3-34. When the associated SUSPSRC bit is '0', the peripheral's emulation suspend signal is controlled by the ARM emulator and when set to '1' it is controlled by the DSP emulator.

**Figure 3-9. Emulation Suspend Source Register (SUSPSRC)**

31	30	29	28	27	26	25	24	23	22	21	20	19	18	17	16
VICP SRC	VICP EN	TIMR2 SRC	TIMR1 SRC	TIMR0 SRC	GPIO SRC	PWM2 SRC	PWM1 SRC	PWM0 SRC	SPI SRC	UART2 SRC	UART1 SRC	UART0 SRC	I2C SRC	ASP SRC	Rsvd
R/W-0	R/W-0	R/W-0	R/W-0	R/W-0	R/W-0	R/W-0	R/W-0	R/W-0	R/W-0	R/W-0	R/W-0	R/W-0	R/W-0	R/W-0	R-0
15	14	13	12	11	10	9	8	7	6	5	4	3	2	1	0
Rsvd		HPI SRC	Rsvd		USB SRC	Rsvd			EMAC SRC	Reserved					
R-000		R/W-0	R-00		R/W-0	R-000			R/W-0	R-0 0000					

LEGEND: R = Read, W = Write, n = value at reset

**Table 3-34. SUSPSRC Register Description**

Name	Description
VICPSRC	Video Imaging Coprocessor emulation suspend source 0 = ARM emulation suspend 1 = DSP emulation suspend
VICPEN	Video Imaging Coprocessor emulation suspend enable 0 = Emulation suspend ignored by VICP 1 = VICP emulation suspend enabled
TIMR2SRC	Timer2 (WD Timer) emulation suspend source 0 = ARM emulation suspend 1 = DSP emulation suspend
TIMR1SRC	Timer1 emulation suspend source 0 = ARM emulation suspend 1 = DSP emulation suspend
TIMR0SRC	Timer0 emulation suspend source 0 = ARM emulation suspend 1 = DSP emulation suspend
GPIO SRC	GPIO emulation suspend source 0 = ARM emulation suspend 1 = DSP emulation suspend
PWM2SRC	PWM2 emulation suspend source 0 = ARM emulation suspend 1 = DSP emulation suspend
PWM1SRC	PWM1 emulation suspend source 0 = ARM emulation suspend 1 = DSP emulation suspend
PWM0 SRC	PWM0 emulation suspend source 0 = ARM emulation suspend 1 = DSP emulation suspend
SPI SRC	SPI emulation suspend source 0 = ARM emulation suspend 1 = DSP emulation suspend

**Table 3-34. SUSPSRC Register Description (continued)**

Name	Description
UART2SRC	UART2 emulation suspend source 0 = ARM emulation suspend 1 = DSP emulation suspend
UART1SRC	UART1 emulation suspend source 0 = ARM emulation suspend 1 = DSP emulation suspend
UART0SRC	UART0 emulation suspend source 0 = ARM emulation suspend 1 = DSP emulation suspend
I2CSRC	I2C emulation suspend source 0 = ARM emulation suspend 1 = DSP emulation suspend
ASPSRC	ASP emulation suspend source 0 = ARM emulation suspend 1 = DSP emulation suspend
HPISRC	HPI emulation suspend source 0 = ARM emulation suspend 1 = DSP emulation suspend
USBSRC	USB emulation suspend source 0 = ARM emulation suspend 1 = DSP emulation suspend
EMACSRC	Ethernet MAC emulation suspend source 0 = ARM emulation suspend 1 = DSP emulation suspend



## 4 System Interconnect

On the DM6446 device, the C64x+ megamodule, the ARM subsystem, the EDMA3 transfer controllers, and the system peripherals are interconnected through a switch fabric architecture (shown in [Figure 4-1](#)). The switch fabric is composed of multiple switched central resources (SCRs) and multiple bridges. The SCRs establish low-latency connectivity between master peripherals and slave peripherals. Additionally, the SCRs provide priority-based arbitration and facilitate concurrent data movement between master and slave peripherals. Through SCR, the ARM subsystem can send data to the DDR2 Memory Controller without affecting a data transfer between the EMAC and L2 memory. Bridges are mainly used to perform bus-width conversion as well as bus operating frequency conversion. For example, in [Figure 4-1](#), Bridge 8 performs a frequency conversion between a bus operating at DSP/6 clock rate and a bus operating at DSP/3 clock rate. Furthermore, Bridge 3 performs a bus-width conversion between a 64-bit bus and a 32-bit bus.

The C64x+ megamodule, the ARM subsystem, the EDMA3 transfer controllers, and the various system peripherals can be classified into two categories: master peripherals and slave peripherals. Master peripherals are typically capable of initiating read and write transfers in the system and do not rely on the EDMA3 or on a CPU to perform transfers to and from them. The system master peripherals include the C64x+ megamodule, the ARM subsystem, the EDMA3 transfer controllers, CF/ATA, VLYNQ, EMAC, USB, and VPSS. Not all master peripherals may connect to all slave peripherals. The supported connections are designated by an X in [Table 4-1](#).

**Table 4-1. System Connection Matrix**

MASTER	SLAVE			
	C64x+	ARM	DDR2 MEMORY CONTROLLER	SCR3 <sup>(1)</sup>
C64x+		X	X	X
ARM	X		X	X
VPSS			X	
CF/ATA	X	X	X	X
VLYNQ	X	X	X	X
EMAC	X	X	X	X
USB	X	X	X	X
EDMA3TC0	X	X	X	X
EDMA3TC1	X	X	X	X
HPI		X	X	X <sup>(2)</sup>

(1) The C64x+ megamodule has access to only the following peripherals connected to SCR3: EDMA3, ASP, and Timers. All other peripherals/modules that support a connection to SCR3 have access to all peripherals/modules connected to SCR3.

(2) HPI's access to SCR3 is limited to the power and sleep controller registers, PLL1 and PLL2 registers, and HPI configuration registers.

## 4.1 System Interconnect Block Diagram

Figure 4-1 displays the DM6446 system interconnect block diagram. The following is a list that helps interpret this diagram:

- The direction of the arrows indicates either bus master or bus slave.
- The arrow originates at a bus master and terminates at a bus slave.
- The direction of the arrows does not indicate the direction of data flow. Data flow is typically bi-directional for each of the documented bus paths.
- The pattern of each arrow's line indicates the clock rate at which it is operating, either DSP/2, DSP/3, DSP/6, or MXI/CLKIN rate.
- Some peripherals may have multiple instances shown in the diagram. A peripheral may have multiple instances shown for a variety of reasons, some of which are described below:
  - The peripheral/module has master port(s) for data transfers, as well as slave port(s) for register access, data access, and/or memory access. Examples of these peripherals are C64x+ megamodule, EDMA3, CF/ATA, USB, EMAC, VPSS, VLYNQ, and HPI.
  - The peripheral/module has a master port as well as slave memories. Examples of these are the C64x+ megamodule and the ARM subsystem.

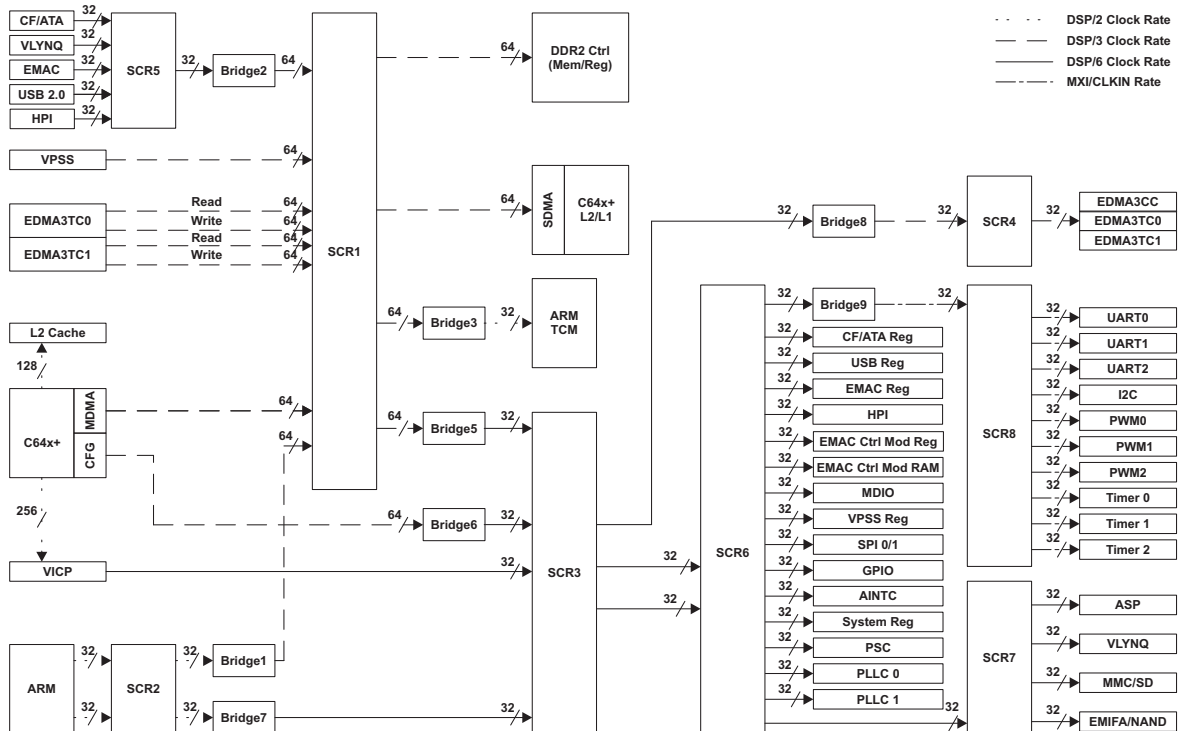

Figure 4-1. System Interconnect Block Diagram

## 5 Device Operating Conditions

### 5.1 Absolute Maximum Ratings Over Operating Case Temperature Range (Unless Otherwise Noted) <sup>(1)</sup>

Supply voltage ranges	Core (CV <sub>DD</sub> , V <sub>DDA1P1V</sub> , USB_V <sub>DDA1P2LDO</sub> <sup>(2)</sup> , CV <sub>DDDSP</sub> ) <sup>(3)</sup>	-0.5 V to 1.5 V
	I/O, 3.3V (DV <sub>DD33</sub> , USB_V <sub>DDA3P3</sub> ) <sup>(3)</sup>	-0.5 V to 4.2 V
	I/O, 1.8V (DV <sub>DD18</sub> , DV <sub>DDR2</sub> , DDR_V <sub>DDDLL</sub> , PLLV <sub>DD18</sub> , V <sub>DDA1P8V</sub> , USB_V <sub>DD1P8</sub> , MXV <sub>DD</sub> , M24V <sub>DD</sub> ) <sup>(3)</sup>	-0.5 V to 2.5 V
Input voltage ranges	V <sub>I</sub> I/O, 3.3V	-0.5 V to 4.2 V
	V <sub>I</sub> I/O, 1.8V	-0.5 V to 2.5 V
Output voltage ranges	V <sub>O</sub> I/O, 3.3V	-0.5 V to 4.2 V
	V <sub>O</sub> I/O, 1.8V	-0.5 V to 2.5 V
Operating case temperature ranges, T <sub>C</sub>		-40°C to 105°C
Storage temperature range, T <sub>stg</sub>	(default)	-55°C to 150°C

- (1) Stresses beyond those listed under "absolute maximum ratings" may cause permanent damage to the device. These are stress ratings only, and functional operation of the device at these or any other conditions beyond those indicated under "recommended operating conditions" is not implied. Exposure to absolute-maximum-rated conditions for extended periods may affect device reliability.
- (2) This pin is an internal LDO output and connected via 1 μF capacitor to USB\_V<sub>SSA1P2LDO</sub>.
- (3) All voltage values are with respect to V<sub>SS</sub>.

## 5.2 Recommended Operating Conditions

		MIN	NOM	MAX	UNIT
CV <sub>DD</sub>	Supply voltage, Core (CV <sub>DD</sub> , V <sub>DDA1P1V</sub> , USB_V <sub>DDA1P2LDO</sub> <sup>(1)</sup> , CV <sub>DDDSP</sub> ) <sup>(2)</sup>	1.14	1.2	1.26	V
DV <sub>DD</sub>	Supply voltage, I/O, 3.3V (DV <sub>DD33</sub> , USB_DV <sub>DDA3P3</sub> )	3.15	3.3	3.45	V
	Supply voltage, I/O, 1.8V (DV <sub>DD18</sub> , DV <sub>DDR2</sub> , DDR_V <sub>DDLL</sub> , PLLV <sub>DD18</sub> , V <sub>DDA1P8V</sub> , USB_V <sub>DD1P8</sub> , MXV <sub>DD</sub> , M24V <sub>DD</sub> )	1.71	1.8	1.89	V
V <sub>SS</sub>	Supply ground (V <sub>SS</sub> , V <sub>SSA1P8V</sub> , V <sub>SSA1P1V</sub> , DDR_V <sub>SSDLL</sub> , USB_V <sub>SSREF</sub> , USB_V <sub>SS1P8</sub> , USB_V <sub>SSA3P3</sub> , USB_V <sub>SSA1P2LDO</sub> , MXV <sub>SS</sub> <sup>(3)</sup> , M24V <sub>SS</sub> <sup>(3)</sup> )	0	0	0	V
DDR_VREF	DDR2 reference voltage <sup>(4)</sup>	0.49DV <sub>DDR2</sub>	0.5DV <sub>DDR2</sub>	0.51DV <sub>DDR2</sub>	V
DDR_ZP	DDR2 impedance control, connected via 200 Ω resistor to V <sub>SS</sub>		V <sub>SS</sub>		V
DDR_ZN	DDR2 impedance control, connected via 200 Ω resistor to DV <sub>DDR2</sub>		DV <sub>DDR2</sub>		V
DAC_VREF	DAC reference voltage input	0.475	0.5	0.525	V
DAC_RBIAS	DAC biasing, connected via 4 kΩ resistor to V <sub>SSA1P8V</sub>		V <sub>SSA1P8V</sub>		V
USB_VBUS	USB external charge pump input	4.75	5	5.25	V
V <sub>IH</sub>	High-level input voltage, I/O, 3.3V	2			V
	High-level input voltage, non-DDR I/O, 1.8V	0.65DV <sub>DD</sub>			V
V <sub>IL</sub>	Low-level input voltage, I/O, 3.3V			0.8	V
	Low-level input voltage, non-DDR I/O, 1.8V			0.35DV <sub>DD</sub>	V
T <sub>C</sub>	Operating case temperature	-40		105	°C
F <sub>SYCLK1</sub>	DSP Operating Frequency (SYCLK1)	20		594	MHz

- (1) This pin is an internal LDO output and connected via 1 μF capacitor to USB\_V<sub>SSA1P2LDO</sub>.
- (2) Future variants of TI SOC devices may operate at voltages ranging from 0.9 V to 1.4 V to provide a range of system power/performance options. TI highly recommends that users design-in a supply that can handle multiple voltages within this range (i.e., 1.0 V, 1.05 V, 1.1 V, 1.14 V, 1.2, 1.26 V with ±3% tolerances) by implementing simple board changes such as reference resistor values or input pin configuration modifications. Not incorporating a flexible supply may limit the system's ability to easily adapt to future versions of TI SOC devices.
- (3) Oscillator ground must be kept separate from other grounds and connected directly to the crystal load capacitor ground.
- (4) DDR\_VREF is expected to equal 0.5DV<sub>DDR2</sub> of the transmitting device and to track variations in the DV<sub>DDR2</sub>.

### 5.3 Electrical Characteristics Over Recommended Ranges of Supply Voltage and Operating Case Temperature (Unless Otherwise Noted)

PARAMETER		TEST CONDITIONS <sup>(1)</sup>	MIN	TYP	MAX	UNIT
V <sub>OH</sub>	Low/full speed: USB_DN and USB_DP		2.8		USB_V <sub>DDAP3</sub>	V
	High speed: USB_DN and USB_DP		360		440	mV
	High-level output voltage (3.3V I/O)	DV <sub>DD33</sub> = MIN, I <sub>OH</sub> = MAX	2.4			V
	High-level output voltage (1.8V I/O)	DV <sub>DD18</sub> = MIN, I <sub>OH</sub> = MAX	DV <sub>DD</sub> - 0.45			V
V <sub>OL</sub>	Low/full speed: USB_DN and USB_DP		0.0		0.3	V
	High speed: USB_DN and USB_DP		-10		10	mV
	Low-level output voltage (3.3V I/O)	DV <sub>DD33</sub> = MIN, I <sub>OL</sub> = MAX			0.4	V
	Low-level output voltage (1.8V I/O)	DV <sub>DD18</sub> = MIN, I <sub>OL</sub> = MAX			0.45	V
I <sub>I</sub> <sup>(2)</sup>	Input current	V <sub>I</sub> = V <sub>SS</sub> to DV <sub>DD</sub> without opposing internal resistor			±10	µA
		V <sub>I</sub> = V <sub>SS</sub> to DV <sub>DD</sub> with opposing internal pullup resistor <sup>(3)</sup>	50	100	250	µA
		V <sub>I</sub> = V <sub>SS</sub> to DV <sub>DD</sub> with opposing internal pulldown resistor <sup>(3)</sup>	-250	-100	-50	µA
I <sub>OH</sub>	High-level output current	All peripherals			-4	mA
I <sub>OL</sub>	Low-level output current	All peripherals			4	mA
I <sub>OZ</sub> <sup>(4)</sup>	I/O Off-state output current	V <sub>O</sub> = DV <sub>DD</sub> or V <sub>SS</sub> ; internal pull disabled			±20	µA
		V <sub>O</sub> = DV <sub>DD</sub> or V <sub>SS</sub> ; internal pull enabled		±100		µA
I <sub>CDD</sub>	Core (CV <sub>DD</sub> , V <sub>DDA1P1V</sub> , V <sub>DDA1P2LDO</sub> <sup>(5)</sup> , CV <sub>DDDSP</sub> ) supply current <sup>(6)</sup>	CV <sub>DD</sub> = 1.2 V, DSP clock = 594 MHz		767		mA
I <sub>DDD</sub>	3.3V I/O (DV <sub>DD33</sub> , USB_V <sub>DDA3P3</sub> ) supply current <sup>(6)</sup>	DV <sub>DD</sub> = 3.3 V, DSP clock = 594 MHz		6		mA
I <sub>DDD</sub>	1.8V I/O (DV <sub>DD18</sub> , DV <sub>DDR2</sub> , DDR_V <sub>DDDLL</sub> , PLLV <sub>DD18</sub> , V <sub>DDA1P8V</sub> , USB_V <sub>DD1P8</sub> , MXVDD, M24VDD) supply current <sup>(6)</sup>	DV <sub>DD</sub> = 1.8 V, DSP clock = 594 MHz		102		mA
C <sub>I</sub>	Input capacitance				4	pF
C <sub>O</sub>	Output capacitance				4	pF

- (1) For test conditions shown as MIN, MAX, or NOM, use the appropriate value specified in the recommended operating conditions table.
- (2) I<sub>I</sub> applies to input-only pins and bi-directional pins. For input-only pins, I<sub>I</sub> indicates the input leakage current. For bi-directional pins, I<sub>I</sub> indicates the input leakage current and off-state (Hi-Z) output leakage current.
- (3) Applies only to pins with an internal pullup (IPU) or pulldown (IPD) resistor.
- (4) I<sub>OZ</sub> applies to output-only pins, indicating off-state (Hi-Z) output leakage current.
- (5) This pin is an internal LDO output and connected via 1 µF capacitor to USB\_V<sub>SSA1P2LDO</sub>.
- (6) Measured under the following conditions: 60% DSP CPU utilization; ARM doing typical activity (peripheral configurations, other housekeeping activities); DDR2 Memory Controller at 50% utilization (135 MHz), 50% writes, 32 bits, 50% bit switching; 2 MHz ASP at 100% utilization; Timer0 at 100% utilization. At room temperature (25 °C) for typical process devices. The actual current draw varies across manufacturing processes and is highly application-dependent. For more details on core and I/O activity, as well as information relevant to board power supply design, see the [TMS320DM644x Power Consumption Summary](#) application report (literature number [SPRAAD6](#)).

## 6 Peripheral and Electrical Specifications

### 6.1 Parameter Information

#### 6.1.1 Parameter Information Device-Specific Information

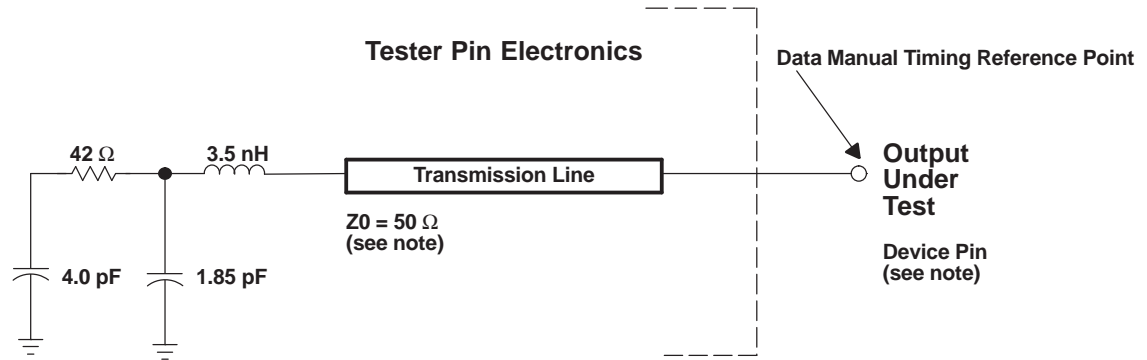

NOTE: The data manual provides timing at the device pin. For output timing analysis, the tester pin electronics and its transmission line effects must be taken into account. A transmission line with a delay of 2 ns or longer can be used to produce the desired transmission line effect. The transmission line is intended as a load only. It is not necessary to add or subtract the transmission line delay (2 ns or longer) from the data manual timings.

Input requirements in this data manual are tested with an input slew rate of < 4 Volts per nanosecond (4 V/ns) at the device pin.

**Figure 6-1. Test Load Circuit for AC Timing Measurements**

The load capacitance value stated is only for characterization and measurement of AC timing signals. This load capacitance value does not indicate the maximum load the device is capable of driving.

##### 6.1.1.1 Signal Transition Levels

All input and output timing parameters are referenced to  $V_{ref}$  for both "0" and "1" logic levels. For 3.3 V I/O,  $V_{ref} = 1.5$  V. For 1.8 V I/O,  $V_{ref} = 0.9$  V.

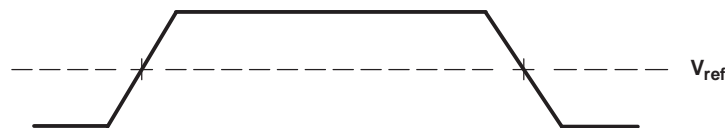

**Figure 6-2. Input and Output Voltage Reference Levels for AC Timing Measurements**

All rise and fall transition timing parameters are referenced to  $V_{IL\ MAX}$  and  $V_{IH\ MIN}$  for input clocks,  $V_{OL\ MAX}$  and  $V_{OH\ MIN}$  for output clocks.

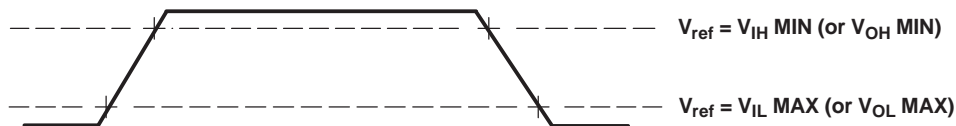

**Figure 6-3. Rise and Fall Transition Time Voltage Reference Levels**

### 6.1.1.2 Timing Parameters and Board Routing Analysis

The timing parameter values specified in this data manual do *not* include delays by board routings. As a good board design practice, such delays must *always* be taken into account. Timing values may be adjusted by increasing/decreasing such delays. TI recommends utilizing the available I/O buffer information specification (IBIS) models to analyze the timing characteristics correctly. To properly use IBIS models to attain accurate timing analysis for a given system, see the *Using IBIS Models for Timing Analysis* application report (literature number SPRA839). If needed, external logic hardware such as buffers may be used to compensate any timing differences.

For the DDR2 memory controller interface, it is *not* necessary to use the IBIS models to analyze timing characteristics. TI provides a PCB routing rules solution that describes the routing rules to ensure the DDR2 memory controller interface timings are met. See the *Implementing DDR2 PCB Layout on the TMS320DM644x DMSoC* Application Report (literature number [SPRAAC5](#)).

## 6.2 Recommended Clock and Control Signal Transition Behavior

All clocks and control signals should transition between  $V_{IH}$  and  $V_{IL}$  (or between  $V_{IL}$  and  $V_{IH}$ ) in a monotonic manner.

## 6.3 Power Supplies

For more information regarding TI's power management products and suggested devices to power TI DSPs, visit [www.ti.com/dsppower](http://www.ti.com/dsppower).

### 6.3.1 Power-Supply Sequencing

The DM6446 includes two core supplies —  $CV_{DD}$  and  $CV_{DDDSP}$ , as well as three I/O supplies —  $DV_{DD18}$ ,  $DV_{DDR2}$ , and  $DV_{DD33}$ . To ensure proper device operation, a specific power-up sequence *must* be followed.

The core supply power-up sequence is dependent on the DSP boot mode selected at reset. If the DSP boot mode is configured as Self-Boot mode, then both core supplies *must* be powered up at the same time.

If the DSP boot mode is configured as Host-Boot, where the ARM boots the DSP, the two core supplies may be ramped simultaneously or powered up separately. When powered up separately, the  $CV_{DDDSP}$  supply *must not* be ramped prior to the  $CV_{DD}$  supply. The  $CV_{DDDSP}$  supply *must* be powered up before the shorting switch is closed (enabled). Prior to powering up the  $CV_{DDDSP}$  supply, it should be left floating and not driven to ground. [Table 6-1](#) and [Figure 6-4](#) describe the power-on sequence timing requirements for DSP Host-Boot mode.

To minimize the voltage difference between these two core supplies, a single regulator source *must* be used to power the  $CV_{DD}$  and  $CV_{DDDSP}$  supplies.

For more information, see [Section 3.2.1](#), *Power Considerations at Reset*.

**Table 6-1. Core Supply Power-On Timing Requirements for DSP Host-Boot Mode (see Figure 6-4)**

NO.		MIN	MAX	UNIT
1	$t_{d(CVDD-CVDDDSP)}$ Delay time, $CV_{DD}$ supply ready to $CV_{DDDSP}$ supply ramp start	0	(1)	ns

(1) In Host-Boot mode, the  $CV_{DDDSP}$  supply *must* be powered up prior to closing (enabling) the shorting switch between the ALWAYS ON and DSP power domains.

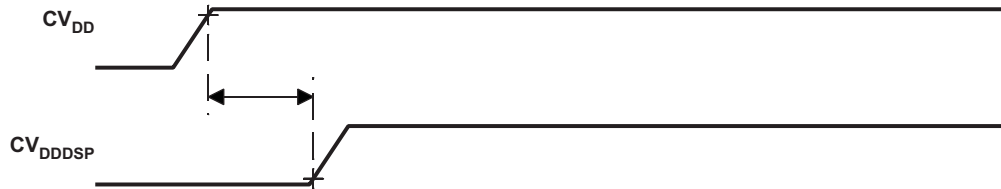
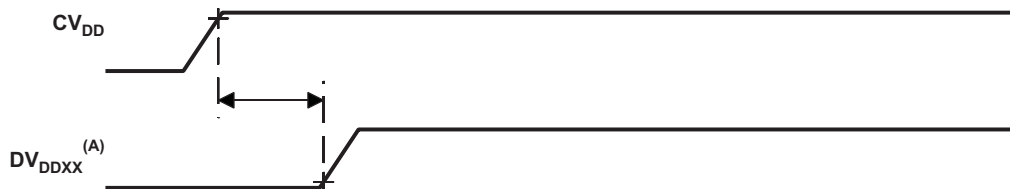

**Figure 6-4. DSP Host-Boot Mode Core Supply Timings**

Once the  $CV_{DD}$  supply has been powered up, the I/O supplies may be powered up. Table 6-2 and Figure 6-5 show the power-on sequence timing requirements for the Core vs. I/O power-up.  $DV_{DDXX}$  is used to denote all I/O supplies. Note: the  $DV_{DDXX}$  supply power-up is specified relative to the  $CV_{DD}$  supply power-up, not the  $CV_{DDDSP}$  supply.

**Table 6-2. I/O Supply Power-On Timing Requirements (see Figure 6-5)**

NO.		MIN	MAX	UNIT
1	$t_{d(CVDD-DVDD)}$ Delay time, $CV_{DD}$ supply ready to $DV_{DDXX}$ supply ramp start	0	100	ms



Note A:  $DV_{DDXX}$  denotes all I/O supplies.

**Figure 6-5. I/O Supply Timings**

There is *not* a specific power-up sequence that must be followed with respect to the order of the power-up of the  $DV_{DD18}$ ,  $DV_{DDR2}$ , and  $DV_{DD33}$  supplies. Once the  $CV_{DD}$  supply is powered up and the  $t_{d(CVDD-DVDDXX)}$  specification is met, the  $DV_{DD18}$ ,  $DV_{DDR2}$ , and  $DV_{DD33}$  supplies may be powered up in any order of preference. All other supplies may also be powered up in any order of preference once the  $t_{d(CVDD-DVDDXX)}$  specification has been met.



### 6.3.1.1 Power-Supply Design Considerations

Core and I/O supply voltage regulators should be located close to the DSP (or DSP array) to minimize inductance and resistance in the power delivery path. Additionally, when designing for high-performance applications utilizing the DM6446 device, the PC board should include separate power planes for core, I/O, and ground, all bypassed with high-quality low-ESL/ESR capacitors.

### 6.3.1.2 Power-Supply Decoupling

In order to properly decouple the supply planes from system noise, place as many capacitors (caps) as possible close to DM6446. Assuming 0603 caps, the user should be able to fit a total of 60 caps, 30 for the core supplies and 30 for the I/O supplies. These caps need to be close to the DM6446 power pins, no more than 1.25 cm maximum distance to be effective. Physically smaller caps, such as 0402, are better because of their lower parasitic inductance. Proper capacitance values are also important. Small bypass caps (near 560 pF) should be closest to the power pins. Medium bypass caps (220 nF or as large as can be obtained in a small package) should be next closest. TI recommends no less than 8 small and 8 medium caps per supply be placed immediately next to the BGA vias, using the "interior" BGA space and at least the corners of the "exterior".

Larger caps for each supply can be placed further away for bulk decoupling. Large bulk caps (on the order of 100  $\mu$ F) should be furthest away, but still as close as possible. Large caps for each supply should be placed outside of the BGA footprint.

Any cap selection needs to be evaluated from a yield/manufacturing point-of-view. As with the selection of any component, verification of capacitor availability over the product's production lifetime should be considered.

### 6.3.1.3 DM6446 Power and Clock Domains

DM6446 includes two separate power domains: "Always On" and "DSP". The "Always On" power domain is always on when the chip is on. The "Always On" domain is powered by the  $V_{DD}$  pins of the DM6446. The majority of the DM6446's modules lie within the "Always On" power domain. A separate domain called the "DSP" domain houses the C64x+ and VICP. The "DSP" domain is not always on. The "DSP" power domain is powered by the  $CV_{DDDSP}$  pins of the DM6446. [Table 6-3](#) provides a listing of the DM6446 power and clock domains.

Two primary reference clocks are required for the DM6446 device. These can either be crystal input or driven by external oscillators. A 27-MHz crystal is recommended for the system PLLs, which generate the internal clocks for the ARM, DSP, coprocessors, peripherals (including imaging peripherals), and EDMA3. The recommended 27-MHz input enables the use of the video DACs to drive NTSC/PAL television signals at the proper frequencies. A 24-MHz crystal is also required if the USB peripheral is to be used. For further description of the DM6446 clock domains, see [Table 6-4](#) and [Figure 6-6](#).

**Table 6-3. DM6446 Power and Clock Domains**

POWER DOMAIN	CLOCK DOMAIN	PERIPHERAL/MODULE
Always On	CLKIN	UART0
Always On	CLKIN	UART1
Always On	CLKIN	UART2
Always On	CLKIN	I2C
Always On	CLKIN	Timer0
Always On	CLKIN	Timer1
Always On	CLKIN	Timer2
Always On	CLKIN	PWM0
Always On	CLKIN	PWM1
Always On	CLKIN	PWM2
Always On	CLKDIV2	ARM Subsystem
Always On	CLKDIV3	DDR2
Always On	CLKDIV3	VPSS
Always On	CLKDIV3	EDMA
Always On	CLKDIV3	SCR
Always On	CLKDIV6	GPSC
Always On	CLKDIV6	LPSCs
Always On	CLKDIV6	Ice Pick
Always On	CLKDIV6	EMIFA
Always On	CLKDIV6	USB
Always On	CLKDIV6	HPI
Always On	CLKDIV6	VLYNQ
Always On	CLKDIV6	EMAC
Always On	CLKDIV6	ATA/CF
Always On	CLKDIV6	MMC/SD/SDIO
Always On	CLKDIV6	SPI
Always On	CLKDIV6	ASP
Always On	CLKDIV6	GPIO
DSP	CLKDIV1	C64x+ CPU

**Table 6-4. DM6446 Clock Domains<sup>(1)</sup>**

SUBSYSTEM	FIXED RATIO vs. PLL1	CLOCK MODES (FREQUENCY)	
		PLL BYPASS	PLL ENABLED
PLL1	–	27 MHz	594 MHz
DSP	1:1	27 MHz	594 MHz
ARM	1:2	13.5 MHz	297 MHz
EDMA3/VPSS	1:3	9 MHz	198 MHz
Peripherals	1:6	4.5 MHz	99 MHz

(1) These table values assume a MXI/CLKIN of 27 MHz and a PLL1 multiplier equal to 22.

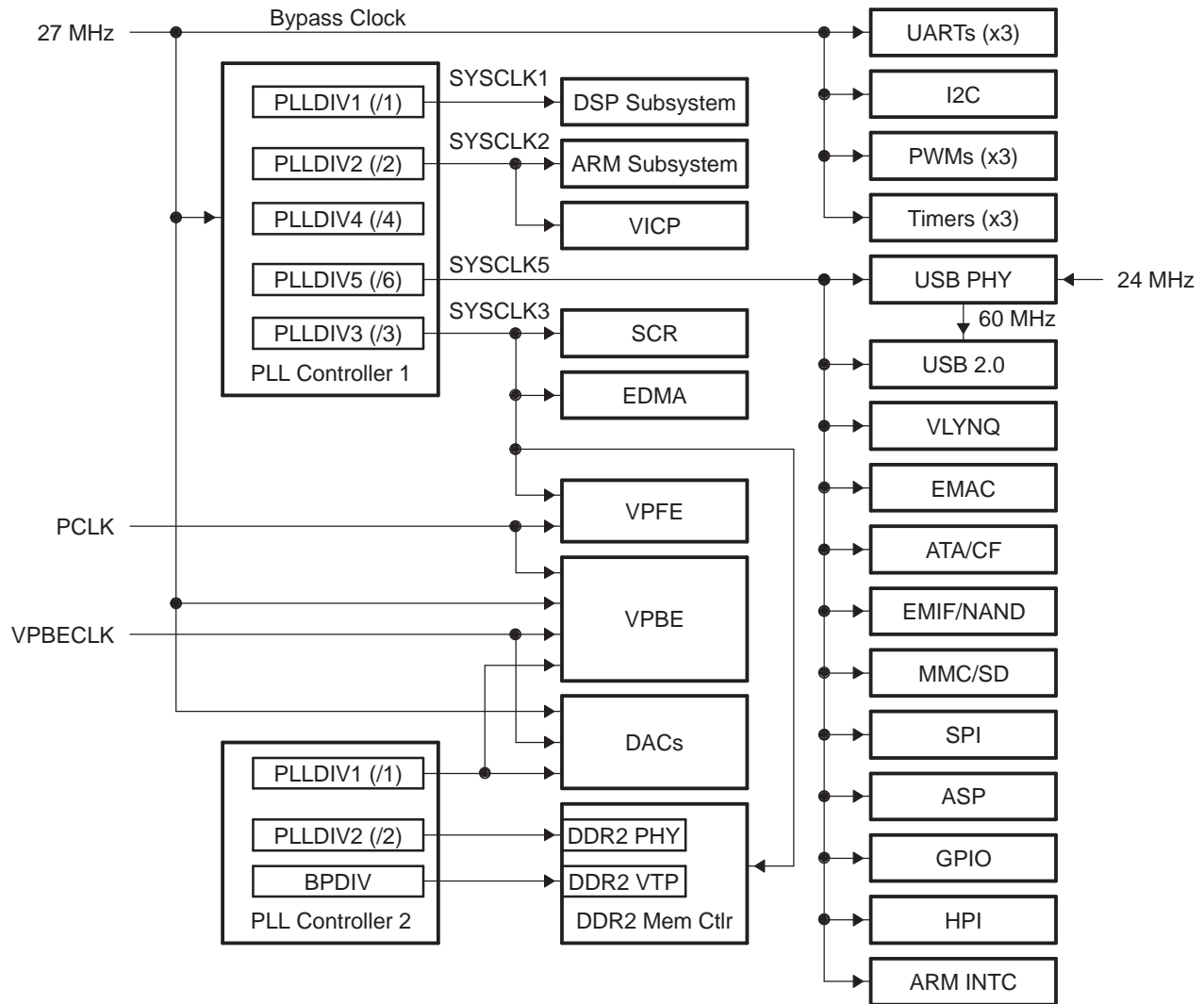

**Figure 6-6. PLL1 and PLL2 Clock Domain Block Diagram**

For further detail on PLL1 and PLL2, see the structure block diagrams [Figure 6-7](#) and [Figure 6-8](#), respectively.

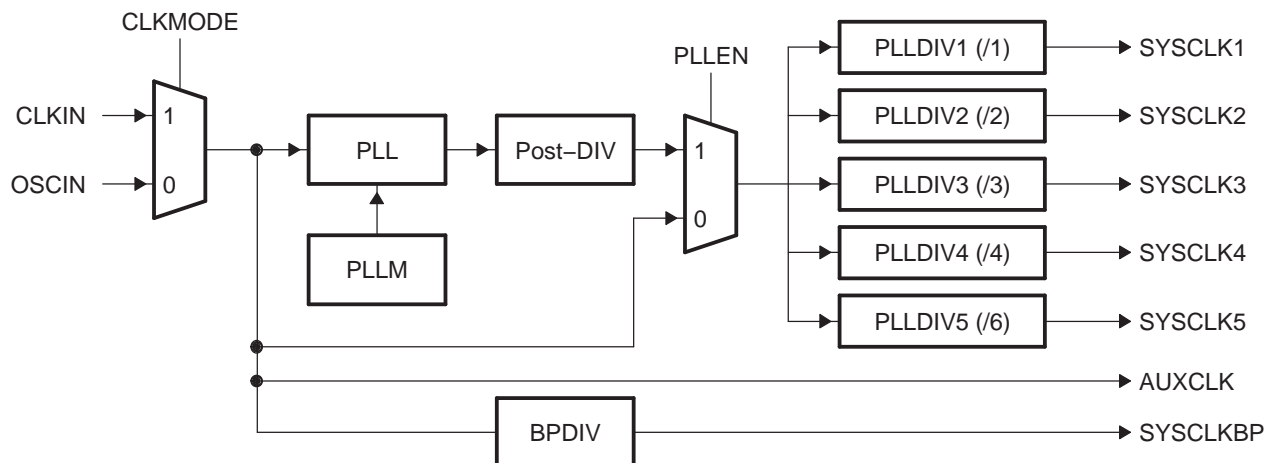

Figure 6-7. PLL1 Structure Block Diagram

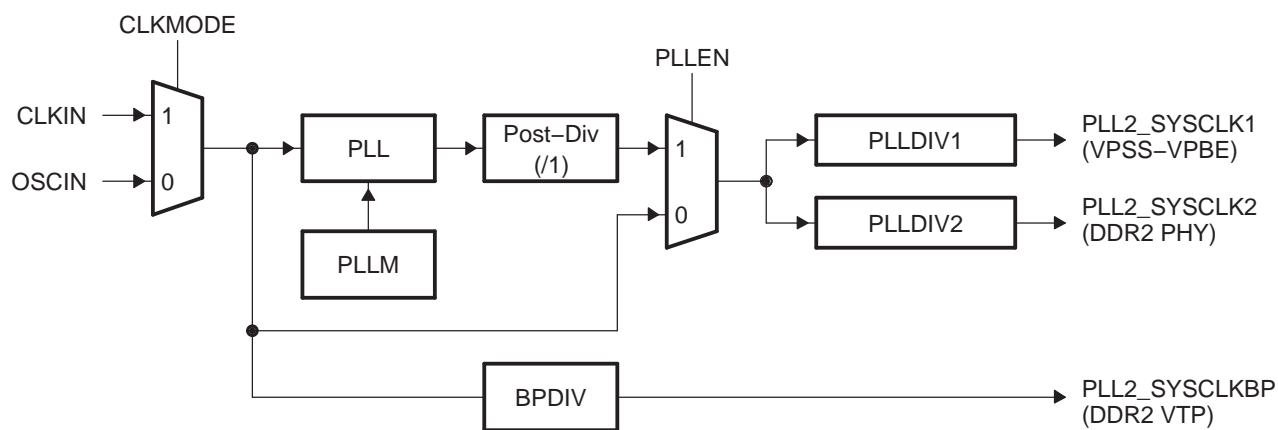

Figure 6-8. PLL2 Structure Block Diagram

#### 6.3.1.4 Power and Sleep Controller (PSC) Module

The Power and Sleep Controller (PSC) controls DM6446 device power by turning off unused power domains or gating off clocks to individual peripherals/modules. The PSC consists of a Global PSC (GPSC) and a set of Local PSCs (LPSCs). The GPSC contains memory mapped registers, power domain control, PSC interrupt control, and a state machine for each peripheral/module. An LPSC is associated with each peripheral/module and provides clock and reset control. The GPSC controls all of DM6446's LPSCs. The ARM subsystem does not have an LPSC module. ARM sleep mode is accomplished through the wait for interrupt instruction. The LPSCs for DM6446 are shown in [Table 6-5](#). The PSC register memory map is given in [Table 6-6](#). For more details on the PSC, see the *Documentation Support* section of the *TMS320DM644x DMSoC ARM Subsystem Reference Guide* (literature number [SPRUE14](#)).

**Table 6-5. DM6446 LPSC Assignments**

LPSC NUMBER	PERIPHERAL/MODULE	LPSC NUMBER	PERIPHERAL/MODULE	LPSC NUMBER	PERIPHERAL/MODULE
0	VPSS DMA	14	EMIFA	28	TIMER1
1	VPSS MMR	15	MMC/SD/SDIO	29	Reserved
2	EDMACC	16	Reserved	30	Reserved
3	EDMATC0	17	ASP	31	Reserved
4	EDMATC1	18	I2C	32	Reserved
5	EMAC	19	UART0	33	Reserved
6	EMAC Memory Controller	20	UART1	34	Reserved
7	MDIO	21	UART2	35	Reserved
8	Reserved	22	SPI	36	Reserved
9	USB	23	PWM0	37	Reserved
10	ATA/CF	24	PWM1	38	Reserved
11	VLYNQ	25	PWM2	39	C64x+ CPU
12	HPI	26	GPIO	40	VICP
13	DDR2 Memory Controller	27	TIMER0		

**Table 6-6. PSC Register Memory Map**

HEX ADDRESS RANGE	REGISTER ACRONYM	DESCRIPTION
0x01C4 1000	PID	Peripheral Revision and Class Information Register
0x01C4 1003 - 0x01C4 101F	-	Reserved
0x01C4 1010	GBLCTL	Global Control Register
0x01C4 1014	-	Reserved
0x01C4 1018	INTEVAL	Interrupt Evaluation Register
0x01C4 101C - 0x01C4 103F	-	Reserved
0x01C4 1040	MERRPR0	Module Error Pending 0 (mod 0 - 31) Register
0x01C4 1044	MERRPR1	Module Error Pending 1 (mod 32- 63) Register
0x01C4 1048 - 0x01C4 104F	-	Reserved
0x01C4 1050	MERRCR0	Module Error Clear 0 (mod 0 - 31) Register
0x01C4 1054	MERRCR1	Module Error Clear 1 (mod 32 - 63) Register
0x01C4 1058 - 0x01C4 105F	-	Reserved
0x01C4 1060	PERRPR	Power Error Pending Register
0x01C4 1064 - 0x01C4 1067	-	Reserved
0x01C4 1068	PERRCR	Power Error Clear Register
0x01C4 106C - 0x01C4 106F	-	Reserved
0x01C4 1070	EPCPR	External Power Error Pending Register
0x01C4 1074 - 0x01C4 1077	-	Reserved
0x01C4 1078	EPCCR	External Power Control Clear Register
0x01C4 107C - 0x01C4 10FF	-	Reserved
0x01C4 1100	RAILSTAT	Power Rail Status Register
0x01C4 1104	RAILCTL	Power Rail Control Register
0x01C4 1108	RAILSEL	Power Rail Counter Select Register
0x01C4 110C - 0x01C4 111F	-	Reserved
0x01C4 1120	PTCMD	Power Domain Transition Command Register
0x01C4 1124 - 0x01C4 1127	-	Reserved
0x01C4 1128	PTSTAT	Power Domain Transition Status Register
0x01C4 112C - 0x01C4 11FF	-	Reserved

**Table 6-6. PSC Register Memory Map (continued)**

HEX ADDRESS RANGE	REGISTER ACRONYM	DESCRIPTION
0x01C4 1200	PDSTAT0	Power Domain Status 0 Register (Always On)
0x01C4 1204	PDSTAT1	Power Domain Status 1 Register (DSP)
0x01C4 1208 - 0x01C4 12FF	-	Reserved
0x01C4 1300	PDCTL0	Power Domain Control 0 Register (Always On)
0x01C4 1304	PDCTL1	Power Domain Control 1 Register (DSP)
0x01C4 1308 - 0x01C4 150F	-	Reserved
0x01C4 1510	MCKOUT0	Module Clock Output Status (mod 0-31) Register
0x01C4 1514	MCKOUT1	Module Clock Output Status (mod 32-63) Register
0x01C4 1518 - 0x01C4 15FF	-	Reserved
0x01C4 1600	MDCFG0	Module Configuration 0 Register (VPSS DMA)
0x01C4 1604	MDCFG1	Module Configuration 1 Register (VPSS MMR)
0x01C4 1608	MDCFG2	Module Configuration 2 Register (EDMACC)
0x01C4 160C	MDCFG3	Module Configuration 3 Register (EDMATC0)
0x01C4 1610	MDCFG4	Module Configuration 4 Register (EDMATC1)
0x01C4 1614	MDCFG5	Module Configuration 5 Register (EMAC)
0x01C4 1618	MDCFG6	Module Configuration 6 Register (EMAC Memory Controller)
0x01C4 161C	MDCFG7	Module Configuration 7 Register (MDIO)
0x01C4 1620		Reserved
0x01C4 1624	MDCFG9	Module Configuration 9 Register (USB)
0x01C4 1628	MDCFG10	Module Configuration 10 Register (ATA/CF)
0x01C4 162C	MDCFG11	Module Configuration 11 Register (VLYNQ)
0x01C4 1630	MDCFG12	Module Configuration 12 Register (HPI)
0x01C4 1634	MDCFG13	Module Configuration 13 Register (DDR2)
0x01C4 1638	MDCFG14	Module Configuration 14 Register (EMIFA)
0x01C4 163C	MDCFG15	Module Configuration 15 Register (MMC/SD/SDIO)
0x01C4 1640		Reserved
0x01C4 1644	MDCFG17	Module Configuration 17 Register (ASP)
0x01C4 1648	MDCFG18	Module Configuration 18 Register (I2C)
0x01C4 164C	MDCFG19	Module Configuration 19 Register (UART0)
0x01C4 1650	MDCFG20	Module Configuration 20 Register (UART1)
0x01C4 1654	MDCFG21	Module Configuration 21 Register (UART2)
0x01C4 1658	MDCFG22	Module Configuration 22 Register (SPI)
0x01C4 165C	MDCFG23	Module Configuration 23 Register (PWM0)
0x01C4 1660	MDCFG24	Module Configuration 24 Register (PWM1)
0x01C4 1664	MDCFG25	Module Configuration 25 Register (PWM2)
0x01C4 1668	MDCFG26	Module Configuration 26 Register (GPIO)
0x01C4 166C	MDCFG27	Module Configuration 27 Register (TIMER0)
0x01C4 1670	MDCFG28	Module Configuration 28 Register (TIMER1)
0x01C4 1674 - 0x01C4 169B	-	Reserved
0x01C4 169C	MDCFG39	Module Configuration 39 Register (C64x+ CPU)
0x01C4 16A0	MDCFG40	Module Configuration 40 Register (VICP)
0x01C4 16A4 - 0x01C4 17FF	-	Reserved
0x01C4 1800	MDSTAT0	Module Status 0 Register (VPSS DMA)
0x01C4 1804	MDSTAT1	Module Status 1 Register (VPSS MMR)
0x01C4 1808	MDSTAT2	Module Status 2 Register (EDMACC)
0x01C4 180C	MDSTAT3	Module Status 3 Register (EDMATC0)

**Table 6-6. PSC Register Memory Map (continued)**

HEX ADDRESS RANGE	REGISTER ACRONYM	DESCRIPTION
0x01C4 1810	MDSTAT4	Module Status 4 Register (EDMATC1)
0x01C4 1814	MDSTAT5	Module Status 5 Register (EMAC)
0x01C4 1818	MDSTAT6	Module Status 6 Register (EMAC Memory Controller)
0x01C4 181C	MDSTAT7	Module Status 7 Register (MDIO)
0x01C4 1820		Reserved
0x01C4 1824	MDSTAT9	Module Status 9 Register (USB)
0x01C4 1828	MDSTAT10	Module Status 10 Register (ATA/CF)
0x01C4 182C	MDSTAT11	Module Status 11 Register (VLYNQ)
0x01C4 1830	MDSTAT12	Module Status 12 Register (HPI)
0x01C4 1834	MDSTAT13	Module Status 13 Register (DDR2)
0x01C4 1838	MDSTAT14	Module Status 14 Register (EMIFA)
0x01C4 183C	MDSTAT15	Module Status 15 Register (MMC/SD/SDIO)
0x01C4 1840		Reserved
0x01C4 1844	MDSTAT17	Module Status 17 Register (ASP)
0x01C4 1848	MDSTAT18	Module Status 18 Register (I2C)
0x01C4 184C	MDSTAT19	Module Status 19 Register (UART0)
0x01C4 1850	MDSTAT20	Module Status 20 Register (UART1)
0x01C4 1854	MDSTAT21	Module Status 21 Register (UART2)
0x01C4 1858	MDSTAT22	Module Status 22 Register (SPI)
0x01C4 185C	MDSTAT23	Module Status 23 Register (PWM0)
0x01C4 1860	MDSTAT24	Module Status 24 Register (PWM1)
0x01C4 1864	MDSTAT25	Module Status 25 Register (PWM2)
0x01C4 1868	MDSTAT26	Module Status 26 Register (GPIO)
0x01C4 186C	MDSTAT27	Module Status 27 Register (TIMER0)
0x01C4 1870	MDSTAT28	Module Status 28 Register (TIMER1)
0x01C4 1874 - 0x01C4 189B	-	Reserved
0x01C4 189C	MDSTAT39	Module Status 39 Register (C64x+ CPU)
0x01C4 18A0	MDSTAT40	Module Status 40 Register (VICP)
0x01C4 18A4 - 0x01C4 19FF	-	Reserved
0x01C4 1A00	MDCTL0	Module Control 0 Register (VPSS DMA)
0x01C4 1A04	MDCTL1	Module Control 1 Register (VPSS MMR)
0x01C4 1A08	MDCTL2	Module Control 2 Register (EDMACC)
0x01C4 1A0C	MDCTL3	Module Control 3 Register (EDMATC0)
0x01C4 1A10	MDCTL4	Module Control 4 Register (EDMATC1)
0x01C4 1A14	MDCTL5	Module Control 5 Register (EMAC)
0x01C4 1A18	MDCTL6	Module Control 6 Register (EMAC Memory Controller)
0x01C4 1A1C	MDCTL7	Module Control 7 Register (MDIO)
0x01C4 1A20		Reserved
0x01C4 1A24	MDCTL9	Module Control 9 Register (USB)
0x01C4 1A28	MDCTL10	Module Control 10 Register (ATA/CF)
0x01C4 1A2C	MDCTL11	Module Control 11 Register (VLYNQ)
0x01C4 1A30	MDCTL12	Module Control 12 Register (HPI)
0x01C4 1A34	MDCTL13	Module Control 13 Register (DDR2)
0x01C4 1A38	MDCTL14	Module Control 14 Register (EMIFA)
0x01C4 1A3C	MDCTL15	Module Control 15 Register (MMC/SD/SDIO)
0x01C4 1A40		Reserved

**Table 6-6. PSC Register Memory Map (continued)**

HEX ADDRESS RANGE	REGISTER ACRONYM	DESCRIPTION
0x01C4 1A44	MDCTL17	Module Control 17 Register (ASP)
0x01C4 1A48	MDCTL18	Module Control 18 Register (I2C)
0x01C4 1A4C	MDCTL19	Module Control 19 Register (UART0)
0x01C4 1A50	MDCTL20	Module Control 20 Register (UART1)
0x01C4 1A54	MDCTL21	Module Control 21 Register (UART2)
0x01C4 1A58	MDCTL22	Module Control 22 Register (SPI)
0x01C4 1A5C	MDCTL23	Module Control 23 Register (PWM0)
0x01C4 1A60	MDCTL24	Module Control 24 Register (PWM1)
0x01C4 1A64	MDCTL25	Module Control 25 Register (PWM2)
0x01C4 1A68	MDCTL26	Module Control 26 Register (GPIO)
0x01C4 1A6C	MDCTL27	Module Control 27 Register (TIMER0)
0x01C4 1A70	MDCTL28	Module Control 28 Register (TIMER1)
0x01C4 1A74 - 0x01C4 1A9B	-	Reserved
0x01C4 1A9C	MDCTL39	Module Control 39 Register (C64x+ CPU)
0x01C4 1AA0	MDCTL40	Module Control 40 Register (VICP)
0x01C4 1AA4 - 0x01C4 1FFF	-	Reserved
0x01C4 1000	MPFAR	Memory Protection Fault Address Register
0x01C4 1004	MPFSR	Memory Protection Fault Status Register
0x01C4 1008	MPFCR	Memory Protection Fault Command Register
0x01C4 100C	MPAA	Memory Protection Page Attribute Register
0x01C4 1010 - 0x01C4 1FFF	-	Reserved



## 6.4 Reset

DM6446 supports various types of resets. Power-on-reset (POR), warm reset, max reset, system reset, C64x+ local reset, and module reset are summarized in [Table 6-7](#).

**Table 6-7. DM6446 Resets**

Type	Initiator	Description
Power-on-reset (POR)	$\overline{\text{RESET}}$ pin active low while $\overline{\text{TRST}}$ is low.	Global chip reset (Cold reset). Activates the POR signal on chip, which is used to reset test and emulation logic.
Warm reset	$\overline{\text{RESET}}$ pin active low while $\overline{\text{TRST}}$ is high.	Resets everything except for test and emulation logic. ARM emulator stays alive during warm reset, but the C64x+ emulator does not.
Maximum reset	Emulator, WD Timer	Same as Warm reset, except for initiators.
C64x+ Local reset	Software (register bit)	MMR controls the C64x+ reset input. This is used for control of C64x+ reset by the ARM. The C64x+ Slave DMA port is still alive when in local reset.

Power-on-reset (POR) is the global chip reset and it affects test, emulation, and other circuitry. It is invoked by driving the  $\overline{\text{RESET}}$  pin active low while  $\overline{\text{TRST}}$  is held low. A POR is required to place DM6446 into a known good initial state. POR can be asserted prior to ramping the core and I/O voltages or after the core and I/O voltages have reached their proper operating conditions. As a best practice,  $\overline{\text{RESET}}$  should be asserted (held low) during power-up. Prior to deasserting  $\overline{\text{RESET}}$  (low-to-high transition), the core and I/O voltages should be at their proper operating conditions and if an external 27 MHz oscillator is used on the MXI/CLKIN pin, the external clock should also be running at the correct frequency.

Warm reset is activated by driving the  $\overline{\text{RESET}}$  pin active low, while  $\overline{\text{TRST}}$  is inactive high. This does not reset test or ARM emulation logic. An ARM emulator session will stay alive during warm reset, but a C64x+ emulator session will not.

Maximum reset is initiated by the emulator or the watchdog timer and the reset effects are the same as a warm reset. The emulator initiates a maximum reset via the ICEPICK module. When the watchdog timer counter reaches zero, this will initiate a maximum reset to recover from a runaway condition. Both of the maximum reset initiators can be masked by the ARM emulator.

System reset is initiated by the emulator and is a soft reset. Memory contents are maintained. Test, emulation, clock, and power control logic are unaffected. The emulator initiates a system reset via the C64x+ emulation logic, or through ICECRUSHER. Both of these reset initiators are non-maskable resets.

The C64x+ DSP has an internal reset input that allows a host to control it. This reset is configured through a MMR bit (MDCTL[39].LRSTz) in the PSC module. When in C64x+ local reset, the slave DMA port on C64x+ will remain active and the internal memory will be accessible, including access to the VICP memory through the L2 port (UMAP port).

For details on reset control/status registers, see the *TMS320DM644x DMSoC ARM Subsystem Reference Guide* (literature number [SPRUE14](#))

For information on peripheral selection at the rising edge of  $\overline{\text{RESET}}$ , see the *Device Configuration* section of this data manual.

### 6.4.1 Reset Electrical Data/Timing

**Table 6-8. Timing Requirements for Reset (see Figure 6-9)**

NO.			MIN	MAX	UNIT
1	$t_w(\text{RST})$	Width of the $\overline{\text{RESET}}$ pulse	444		ns
2	$t_{su}(\text{BOOT})$	Setup time, boot configuration bits valid before $\overline{\text{RESET}}$ high	444		ns
3	$t_h(\text{BOOT})$	Hold time, boot configuration bits valid after $\overline{\text{RESET}}$ high	444		ns

**Table 6-9. Switching Characteristics Over Recommended Operating Conditions During Reset<sup>(1)</sup>  
(see Figure 6-9)**

NO.			MIN	MAX	UNIT
26	$t_d(\text{PLL\_LOCK})$	Delay time, PLL1 lock time		2000P	ns
4	$t_d(\text{RSTL-DDRZZ})$	Delay time, $\overline{\text{RESET}}$ low to DDR2 Z Group high impedance	0	2P + 20	ns
5	$t_d(\text{RSTL-DDRLL})$	Delay time, $\overline{\text{RESET}}$ low to DDR2 Low Group low	0	20	ns
6	$t_d(\text{RSTL-DDRHH})$	Delay time, $\overline{\text{RESET}}$ low to DDR2 High Group high	0	20	ns
16	$t_d(\text{RSTL-DDRZH})$	Delay time, $\overline{\text{RESET}}$ low to DDR2 Z/High Group high impedance	0	5P + 20	ns
17	$t_d(\text{RSTL-DDRHL})$	Delay time, $\overline{\text{RESET}}$ low to DDR2 Low/High Group low	0	20	ns
7	$t_d(\text{RSTL-ZZ})$	Delay time, $\overline{\text{RESET}}$ low to Z Group high impedance	0	20	ns
8	$t_d(\text{RSTL-LOWL})$	Delay time, $\overline{\text{RESET}}$ low to Low Group low	0	20	ns
9	$t_d(\text{RSTL-HIGHH})$	Delay time, $\overline{\text{RESET}}$ low to High Group high	0	20	ns
18	$t_d(\text{RSTL-HIGHLOWH})$	Delay time, $\overline{\text{RESET}}$ low to High/Low Group high	0	20	ns
19	$t_d(\text{RSTL-LOWHIGHL})$	Delay time, $\overline{\text{RESET}}$ low to Low/High Group low	0	20	ns
24	$t_d(\text{RSTL-ZIZ})$	Delay time, $\overline{\text{RESET}}$ low to Z/Invalid Group high impedance	0	20	ns
10	$t_d(\text{RSTH-DDRZV})$	Delay time, $\overline{\text{RESET}}$ high to DDR2 Z Group valid		<sup>(2)</sup>	ns
11	$t_d(\text{RSTH-DDRLV})$	Delay time, $\overline{\text{RESET}}$ high to DDR2 Low Group valid		<sup>(2)</sup>	ns
12	$t_d(\text{RSTH-DDRHV})$	Delay time, $\overline{\text{RESET}}$ high to DDR2 High Group valid		<sup>(2)</sup>	ns
20	$t_d(\text{RSTH-DDRZH})$	Delay time, $\overline{\text{RESET}}$ high to DDR2 Z/High Group valid high		4000P	ns
21	$t_d(\text{RSTH-DDRHL})$	Delay time, $\overline{\text{RESET}}$ high to DDR2 Low/High Group valid high		4000P	ns
13	$t_d(\text{RSTH-ZV})$	Delay time, $\overline{\text{RESET}}$ high to Z Group valid		<sup>(2)</sup>	ns
14	$t_d(\text{RSTH-LOWV})$	Delay time, $\overline{\text{RESET}}$ high to Low Group valid		<sup>(2)</sup>	ns
15	$t_d(\text{RSTH-HIGHV})$	Delay time, $\overline{\text{RESET}}$ high to High Group valid		<sup>(2)</sup>	ns
22	$t_d(\text{RSTH-HIGHLOWV})$	Delay time, $\overline{\text{RESET}}$ high to High/Low Group valid low		5100P	ns
23	$t_d(\text{RSTH-LOWHIGHV})$	Delay time, $\overline{\text{RESET}}$ high to Low/High Group valid high		5100P	ns
25	$t_d(\text{RSTH-ZIV})$	Delay time, $\overline{\text{RESET}}$ high to Z/Invalid Group invalid		4000P	ns

(1) P = MXI/CLKIN cycle time, in ns.

(2) Following  $\overline{\text{RESET}}$  high, this signal group maintains the state the pins(s) achieved while  $\overline{\text{RESET}}$  was driven low until the peripheral is enabled via the PSC. For example, the DDR2 Z Group goes high impedance following  $\overline{\text{RESET}}$  low and remains in the high-impedance state following  $\overline{\text{RESET}}$  high until the DDR2 controller is enabled via the PSC.

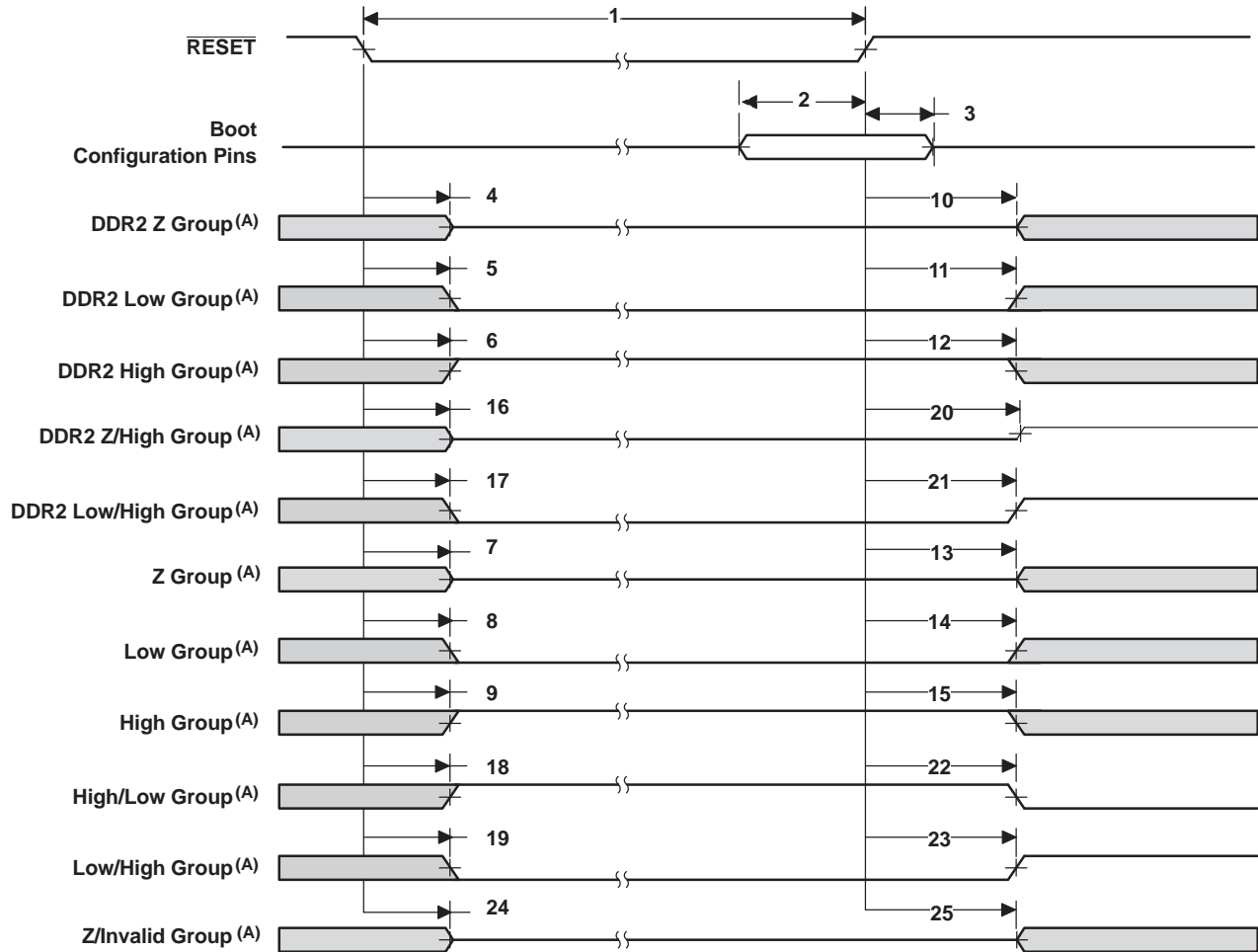

- A. **DDR2 Z Group:** DDR\_DQS[3:0], DDR\_D[12:0]  
**DDR2 Low Group:** DDR\_CLK0, DDR\_CKE, DDR\_A[12:0]  
**DDR2 High Group:** DDR\_CLK0, DDR\_CS, DDR\_WE, DDR\_RAS, DDR\_CAS  
**DDR2 Z/High Group:** DDR\_DQM[3:0],  
**DDR2 Low/High Group:** DDR\_BS[2:0]  
**Low Group:** DMARQ/UART\_RXD1, VCLK, RTCK, TDO, VPBECLK, YOUT0/G5/AEAW0, YOUT1/G6/AEAW1, YOUT2/G7/AEAW2, YOUT3/R3/AEAW3, YOUT4/R4/AEAW4, COUT3/B6/DSP\_BT, COUT2/B5/EM\_WIDTH, COUT1/B4/BTSEL1, COUT0/B3/BTSEL0, TRST  
**High Group:** DMACK/UART\_TXD1, EM\_A[2]/(CLE), EM\_A[1]/(ALE), EM\_CS3, EM\_WE/(WE)(IOWR)/DIOW  
**Z Group:** All other pins not listed above, with the exception of power and ground pins.
- The following Z Group pins have an internal pullup (IPU): DMARQ/UART\_RXD1, VPBECLK, HSYNC, VSYNC, YOUT0/G5/AEAW0, YOUT1/G6/AEAW1, YOUT2/G7/AEAW2, YOUT3/R3/AEAW3, YOUT4/R4/AEAW4, COUT3/B6/DSP\_BT, COUT2/B5/EM\_WIDTH, COUT1/B4/BTSEL1, COUT0/B3/BTSEL0, TRST, YI/CCD[7:0], CI[3:0]/CCD[11:8], CI4/CCD12/UART\_RTS2, CI5/CCD13/UART\_CTS2, CI6/CCD14/UART\_TXD2, CI7/CCD15/UART\_RXD2
  - The following Z Group pins have an internal pulldown (IPD): EM\_WAIT/IORDY, TCK, TDI, TMS, EMU[1:0]
- High/Low Group:** EM\_BA[0]/DA0, EM\_CS2, EM\_OE/(RE)/(IORD)/DIOR  
**Low/High Group:** EM\_R/W/INTRQ  
**Z/Invalid Group:** EM\_D[15:0]

Figure 6-9. Reset Timing

## 6.5 External Clock Input From MXI/CLKIN Pin

The DM6446 device has two input pins for an external clock source, MXI/CLKIN and M24XI. The MXI/CLKIN pin provides the clock source for PLL1 and PLL2 whose optimal frequency is 27 MHz. The M24XI pin provides the clock source for the USB PLL whose optimal frequency is 24 MHz.

The DM6446 device includes two options to provide an external clock input:

1. Use an on-chip oscillator with external crystal or ceramic resonator circuit (only supporting parallel-resonant mode; it does not provide overtone support). For more details, see [Section 6.5.1](#).
2. Use an external 1.8-V LVCMOS-compatible clock input. For more details, see [Section 6.5.2](#).

### 6.5.1 Clock Input Option 1 – Crystal

#### 6.5.1.1 27-MHz Crystal for System Oscillator

In this option, a crystal is used as the external clock input to the DM6446 PLL1 and PLL2.

The 27-MHz oscillator provides the reference clock for all DM6446 subsystems and peripherals. The on-chip oscillator requires an external 27-MHz crystal connected across the MXI and MXO pins, along with two load capacitors, as shown in [Figure 6-10](#). The external crystal load capacitors **must** be connected only to the 27-MHz oscillator ground pin (MXV<sub>SS</sub>). **Do not** connect to board ground (V<sub>SS</sub>). The MXV<sub>DD</sub> pin can be connected to the same 1.8 V power supply as DV<sub>DD18</sub>.

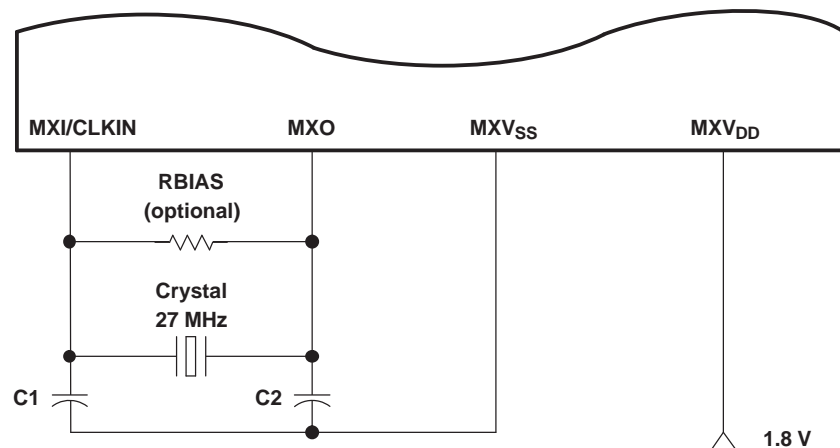

Figure 6-10. 27-MHz System Oscillator

The RBIAS resistor is optional. If the RBIAS resistor is used, it should equal 1 M $\Omega$   $\pm$ 5%. The load capacitors, C1 and C2, should be chosen such that the equation is satisfied (typical values are C1 = C2 = 10 pF). C<sub>L</sub> in the equation is the load specified by the crystal manufacturer. All discrete components used to implement the oscillator circuit should be placed as close as possible to the associated oscillator pins (MXI and MXO) and to the MXV<sub>SS</sub> pin.

$$C_L = \frac{C_1 C_2}{(C_1 + C_2)}$$

Table 6-10. Crystal Requirements for a 27-MHz System Oscillator

PARAMETER	MIN	TYP	MAX	UNIT
Start-up time (from power up until oscillating at stable frequency of 27 MHz)			4	ms
Oscillation frequency		27		MHz
ESR			60	$\Omega$
Frequency stability			$\pm$ 50	ppm

### 6.5.1.2 24-MHz Crystal for USB Oscillator

In this option, a crystal is used as the external clock input to the DM6446 USB PLL.

The 24-MHz oscillator provides the reference clock for the DM6446 USB peripheral. The on-chip oscillator requires an external 24-MHz crystal connected across the M24XI and M24XO pins, along with two load capacitors, as shown in Figure 6-11. The external crystal load capacitors **must** be connected only to the 24-MHz oscillator ground pin (M24V<sub>SS</sub>). **Do not** connect to board ground (V<sub>SS</sub>).

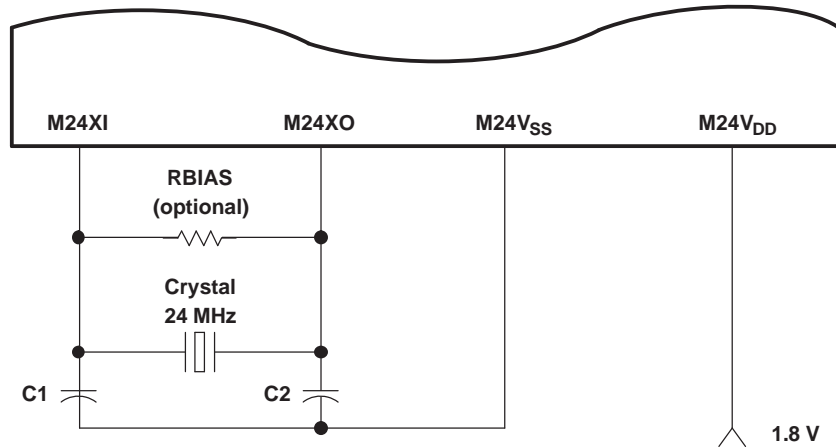

Figure 6-11. 24-MHz USB Oscillator

The RBIAS resistor is optional. If the RBIAS resistor is used, it should equal 1 M $\Omega$   $\pm$ 5%. The load capacitors, C1 and C2, should be chosen such that the equation is satisfied (typical values are C1 = C2 = 10 pF). C<sub>L</sub> in the equation is the load specified by the crystal manufacturer. All discrete components used to implement the oscillator circuit should be placed as close as possible to the associated oscillator pins (M24XI and M24XO) and to the M24XV<sub>SS</sub> pin.

$$C_L = \frac{C_1 C_2}{(C_1 + C_2)}$$

Table 6-11. Crystal Requirements for a 24-MHz USB Oscillator

PARAMETER	MIN	TYP	MAX	UNIT
Start-up time (from power up until oscillating at stable frequency of 24 MHz)			4	ms
Oscillation frequency		24		MHz
ESR			60	$\Omega$
Frequency stability			$\pm$ 50	ppm

### 6.5.2 Clock Input Option 2 – 1.8-V LVCMOS-Compatible Clock Input

In this option, a 1.8-V LVCMOS-compatible clock input is used as the external clock input to the DM6446 device. The external connections are shown in Figure 6-12. The MXI/CLKIN pin is connected to the 1.8-V LVCMOS-compatible clock source. The MXO pin is left unconnected. The MXV<sub>SS</sub> pin is connected to board ground (V<sub>SS</sub>). The MXV<sub>DD</sub> pin can be connected to the same 1.8-V power supply as DV<sub>DD18</sub>. The clock source must meet the MXI/CLKIN timing requirements shown in Table 6-16, *Timing Requirements for MXI/CLKIN*.

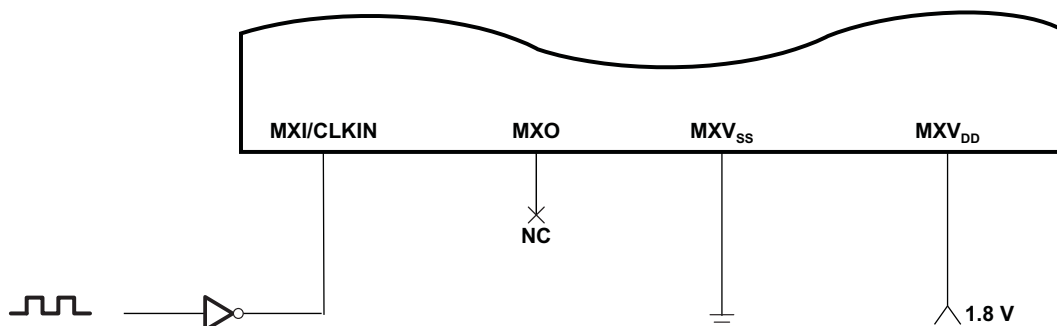

Figure 6-12. 1.8-V LVCMOS-Compatible Clock Input

Figure 6-12 also applies to the USB external clock input. When a 1.8-V LVCMOS-compatible clock input is used as the external clock input, the M24XI pin is connected to the 1.8-V LVCMOS-compatible clock source. The M24XO pin is left unconnected. The M24V<sub>SS</sub> pin is connected to board ground (V<sub>SS</sub>). The M24V<sub>DD</sub> pin can be connected to the same 1.8-V power supply as DV<sub>DDR2</sub>. The clock source must meet the MXI/CLKIN timing requirements shown in Table 6-17, *Timing Requirements for M24XI*.

## 6.6 Clock PLLs

There are two independently controlled PLLs on DM6446. PLL1 generates the frequencies required for the DSP, ARM, VICP, DMA, VPFE, and other peripherals. PLL2 generates the frequencies required for the DDR2 interface and the VPBE in certain modes. The recommended reference clock for both PLLs is the 27-MHz crystal input. The USB2.0 PHY contains a third PLL embedded within it and the 24-MHz oscillator is its reference clock source. This particular PLL is only usable for USB operation, and is discussed further in the *TMS320DM644x DMSoC Universal Serial Bus (USB) Controller User's Guide* (literature number [SPRUE35](#)).

A summary of the PLL controller registers is shown in Table 6-12. For more details, see the *TMS320DM644x DMSoC ARM Subsystem Reference Guide* (literature number [SPRUE14](#)).

Table 6-12. PLL and Reset Controller Registers Memory Map

HEX ADDRESS RANGE	REGISTER ACRONYM	DESCRIPTION
<b>PLL1 Controller Registers</b>		
0x01C4 0800	PID	Peripheral Identification and Revision Information Register
0x01C4 08E4	RSTYPE	Reset Type Register
0x01C4 0900	PLLC	PLL Controller 1 Operations Control Register
0x01C4 0910	PLLM	PLL Controller 1 Multiplier Control Register
0x01C4 0918	PLLDIV1	PLL Controller 1 Control-Divider 1 Register (SYSCLK1)
0x01C4 091C	PLLDIV2	PLL Controller 1 Control-Divider 2 Register (SYSCLK2)
0x01C4 0920	PLLDIV3	PLL Controller 1 Control-Divider 3 Register (SYSCLK3)
0x01C4 0928	POSTDIV	PLL Controller 1 Post-Divider Control Register
0x01C4 092C	BPDIV	PLL Controller 1 Bypass Control-Divider Register (SYSCLKBP)
0x01C4 0938	PLLCMD	PLL Controller 1 Command Register

**Table 6-12. PLL and Reset Controller Registers Memory Map (continued)**

HEX ADDRESS RANGE	REGISTER ACRONYM	DESCRIPTION
0x01C4 093C	PLLSTAT	PLL Controller 1 Status Register (Shows PLLCTRL Status)
0x01C4 0940	ALNCTL	PLL Controller 1 Alignment Control Register (Indicates Which SYSCLKs Need to be Aligned for Proper Device Operation)
0x01C4 0944	DCHANGE	PLL Controller 1 Divider Change Register (Indicates if SYSCLK Divide Ratio has Been Modified)
0x01C4 0948	CKEN	PLL Controller 1 Clock Enable Register
0x01C4 094C	CKSTAT	PLL Controller 1 Clock Status Register (For All Clocks Except SYSCLKx)
0x01C4 0950	SYSTAT	PLL Controller 1 System Clock Status 1 Register (Indicates SYSCLK on/off Status)
0x01C4 0960	PLLDIV4	PLL Controller 1 Control-Divider 4 Register (SYSCLK4)
0x01C4 0964	PLLDIV5	PLL Controller 1 Control-Divider 5 Register (SYSCLK5)
0x01C4 0C00	PID	Peripheral Identification and Revision Information Register
0x01C4 0D00	PLLC	PLL Controller 2 Operations Control Register
0x01C4 0D10	PLLM	PLL Controller 2 Multiplier Control Register
0x01C4 0D18	PLLDIV1	PLL Controller 2 Control-Divider 1 Register (SYSCLK1)
0x01C4 0D1C	PLLDIV2	PLL Controller 2 Control-Divider 2 Register (SYSCLK2)
0x01C4 0D20 - 0x01C4 0D2B	POSTDIV	PLL Controller 2 Post-Divider Control Register
0x01C4 0D2C	BPDIV	PLL Controller 2 Bypass Control-Divider Register (SYSCLKBP)
0x01C4 0D38	PLLCMD	PLL Controller 2 Command Register
0x01C4 0D3C	PLLSTAT	PLL Controller 2 Status Register (Shows PLLCTRL Status)
0x01C4 0D40	ALNCTL	PLL Controller 2 Alignment Control Register (Indicates Which SYSCLKs Need to be Aligned for Proper Device Operation)
0x01C4 0D44	DCHANGE	PLL Controller 2 Divider Change Register (Indicates if SYSCLK Divide Ratio has Been Modified)
0x01C4 0D48	CKEN	PLL Controller 2 Clock Enable Register
0x01C4 0D4C	CKSTAT	PLL Controller 2 Clock Status Register (For All Clocks Except SYSCLKx)
0x01C4 0D50	SYSTAT	PLL Controller 2 System Clock Status 1 Register (Indicates SYSCLK on/off Status)

### 6.6.1 PLL1 and PLL2

Both PLL1 and PLL2 power is supplied externally via the 1.8 V PLL power-supply pin (PLLV<sub>DD18</sub>). It is recommended that an external EMI filter circuit be added to PLLV<sub>DD18</sub>, as shown in [Figure 6-13](#). The 1.8-V supply of the EMI filter must be from the same 1.8-V power plane supplying the device's 1.8-V I/O power-supply pins (DV<sub>DD</sub>). TI recommends EMI filter manufacturer Murata, part number NFM18CC222R1C3.

All PLL external components (C1, C2, and the EMI Filter) **should** be placed as close to the device as possible. For the best performance, TI recommends that all the PLL external components be on a single side of the board without jumpers, switches, or components other than the ones shown in [Figure 6-13](#). For reduced PLL jitter, maximize the spacing between switching signals and the PLL external components (C1, C2, and the EMI Filter).

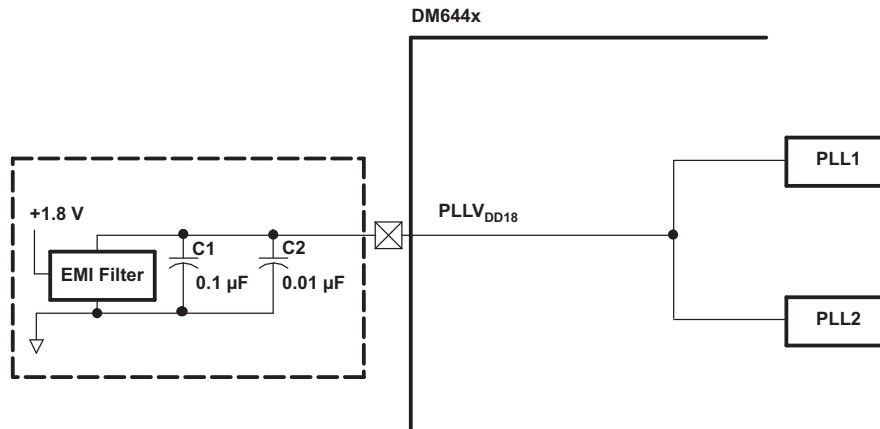

Figure 6-13. PLL1 and PLL2 External Connection

The minimum CLKIN rise and fall times should also be observed. For the input clock timing requirements, see [Section 6.6.3, Clock PLL Electrical Data/Timing \(Input and Output Clocks\)](#).

There is an allowable range for PLL multiplier (PLLM). There is a minimum and maximum operating frequency for MXI/CLKIN, PLL<sub>OUT</sub>, and the device clocks (SYSCLKs). The PLL Controllers **must** be configured not to exceed any of these constraints documented in this section (certain combinations of external clock inputs, internal dividers, and PLL multiply ratios might not be supported).



**Table 6-13. PLLC1 Clock Frequency Ranges**

CLOCK SIGNAL NAME		MIN	MAX	UNIT
MXI/CLKIN <sup>(1)</sup>		20	30	MHz
PLLOUT	At 1.2-V CV <sub>DD</sub>	400	594	MHz
SYSCLK1 (CLKDIV1 Domain)			594	MHz

(1) MXI/CLKIN input clock is used for both PLL Controllers (PLLC1 and PLLC2).

**Table 6-14. PLLC2 Clock Frequency Ranges**

CLOCK SIGNAL NAME		MIN	MAX	UNIT
MXI/CLKIN <sup>(1)</sup>		20	30	MHz
PLLOUT	At 1.2-V CV <sub>DD</sub>	400	900	MHz

(1) MXI/CLKIN input clock is used for both PLL Controllers (PLLC1 and PLLC2).

Both PLL1 and PLL2 have stabilization, lock, and reset timing requirements that **must** be followed.

The PLL stabilization time is the amount of time that **must** be allotted for the internal PLL regulators to become stable after the PLL is powered up (after PLLCTL.PLLPWRDN bit goes through a 1-to-0 transition). The PLL should **not** be operated until this stabilization time has expired. This stabilization step **must** be applied after these resets—a Power-on Reset, a Warm Reset, or a Max Reset, as the PLLCTL.PLLPWRDN bit resets to a "1". For the PLL stabilization time value, see [Table 6-15](#).

The PLL reset time is the amount of wait time needed for the PLL to properly reset (writing PLLRST = 0) before bringing the PLL out of reset (writing PLLRST = 1). For the PLL reset time value, see [Table 6-15](#).

The PLL lock time is the amount of time needed from when the PLL is taken out of reset (PLLRST = 1 with PLEN = 0) to when to when the PLL controller can be switched to PLL mode (PLEN = 1). For the PLL lock time value, see [Table 6-15](#).

**Table 6-15. PLL1 and PLL2 Stabilization, Lock, and Reset Times**

PLL STABILIZATION/LOCK/RESET TIME	MIN	TYP	MAX	UNIT
PLL Stabilization Time	150			μs
PLL Lock Time			2000C <sup>(1)</sup>	ns
PLL Reset Time	128C <sup>(1)</sup>			ns

(1) C = CLKIN cycle time in ns. For example, when MXI/CLKIN frequency is 27 MHz, use C = 37.037 ns.

For details on the PLL initialization software sequence, see the *TMS320DM6446 DMSoC ARM Subsystem Reference Guide* (literature number [SPRUE14](#)).

## 6.6.2 Clock PLL Considerations with External Clock Sources

If the internal oscillator is bypassed, to minimize the clock jitter a single clean power supply should power both the DM6446 device and the external clock oscillator circuit. The minimum CLKIN rise and fall times should also be observed. For the input clock timing requirements, see [Section 6.6.3, Clock PLL Electrical Data/Timing \(Input and Output Clocks\)](#).

Rise/fall times, duty cycles (high/low pulse durations), and the load capacitance of the external clock source must meet the device requirements in this data manual (see [Section 5.3, Electrical Characteristics Over Recommended Ranges of Supply Voltage and Operating Case Temperature](#) and [Section 6.6.3, Clock PLL Electrical Data/Timing \(Input and Output Clocks\)](#)).

### 6.6.3 Clock PLL Electrical Data/Timing (Input and Output Clocks)

Table 6-16. Timing Requirements for MXI/CLKIN<sup>(1)(2)(3)(4)</sup> (see Figure 6-14)

NO.		MIN	MAX	UNIT
1	$t_{c(MXI)}$ Cycle time, MXI/CLKIN	$33.\bar{3}$	50	ns
2	$t_{w(MXIH)}$ Pulse duration, MXI/CLKIN high	0.45C	0.55C	ns
3	$t_{w(MXIL)}$ Pulse duration, MXI/CLKIN low	0.45C	0.55C	ns
4	$t_{t(MXI)}$ Transition time, MXI/CLKIN		0.05C	ns
5	$t_{J(MXI)}$ Period jitter, MXI/CLKIN		0.02C	ns

- (1) The MXI/CLKIN frequency and PLL multiply factor should be chosen such that the resulting clock frequency is within the specific range for CPU operating frequency. For example, for a -594 speed device with a 27 MHz CLKIN frequency, the PLL multiply factor should be  $\leq 22$ .
- (2) The reference points for the rise and fall transitions are measured at  $V_{IL}$  MAX and  $V_{IH}$  MIN.
- (3) For more details on the PLL multiplier factors, see the *Documentation Support* section for ARM Subsystem User's Guide.
- (4) C = CLKIN cycle time in ns. For example, when MXI/CLKIN frequency is 27 MHz, use C = 37.037 ns.

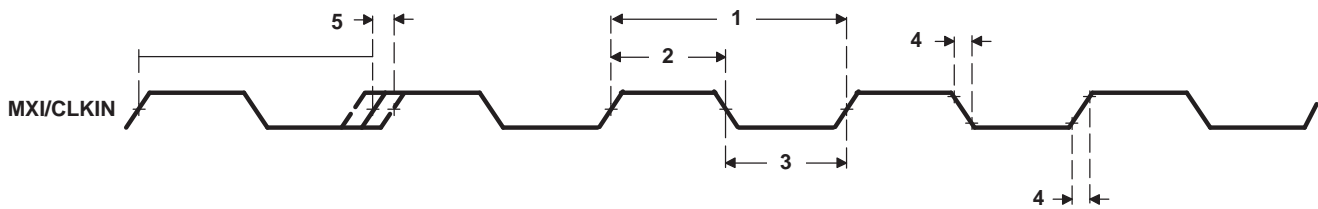

Figure 6-14. MXI/CLKIN Timing

Table 6-17. Timing Requirements for M24XI<sup>(1)(2)(3)</sup> (see Figure 6-15)

NO.			MIN	TYP	MAX	UNIT
1	$t_{c(M24XI)}$	Cycle time, M24XI		41.6		ns
2	$t_{w(M24XIH)}$	Pulse duration, M24XI high	0.45C		0.55C	ns
3	$t_{w(M24XIL)}$	Pulse duration, M24XI low	0.45C		0.55C	ns
4	$t_t(M24XI)$	Transition time, M24XI			0.05C	ns
5	$t_{j(M24XI)}$	Period jitter, M24XI			0.02C	ns

- (1) The reference points for the rise and fall transitions are measured at  $V_{IL}$  MAX and  $V_{IH}$  MIN.
- (2) For more details on the PLL, see the *Documentation Support* section for USB Peripheral Reference Guide.
- (3) C = M24XI cycle time in ns. For example, when M24XI frequency is 24 MHz, use C = 41.6 ns.

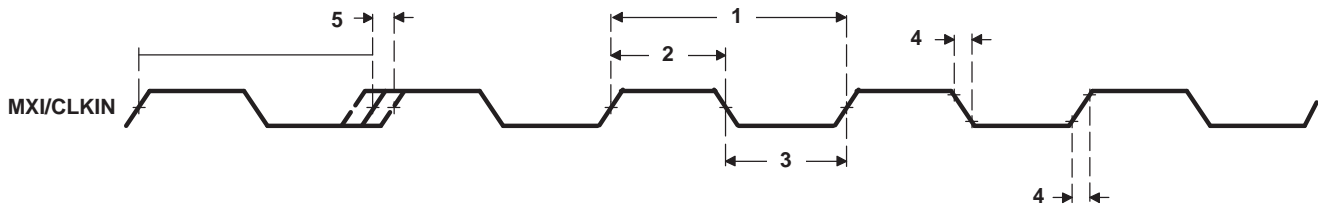

Figure 6-15. M24XI Timing

**Table 6-18. Switching Characteristics Over Recommended Operating Conditions for CLK\_OUT0<sup>(1)(2)</sup>**  
(see [Figure 6-16](#))

NO.	PARAMETER	MIN	MAX	UNIT
1	$t_C$ Cycle time, CLK_OUT0	37.037	74.074	ns
2	$t_{W(CLKOUT0H)}$ Pulse duration, CLK_OUT0 high	0.45P	0.55P	ns
3	$t_{W(CLKOUT0L)}$ Pulse duration, CLK_OUT0 low	0.45P	0.55P	ns
4	$t_t(CLKOUT0)$ Transition time, CLK_OUT0		0.05P	ns
5	$t_d(CLKINH-CLKO0H)$ Delay time, CLKIN/MXI high to CLK_OUT0 high (divide-by-1 only)	1	8	ns
6	$t_d(CLKINL-CLKO0L)$ Delay time, CLKIN/MXI low to CLK_OUT0 low (divide-by-1 only)	1	8	ns
7	$t_d(CLKINH-CLKO0L)$ Delay time, CLKIN/MXI high to CLK_OUT0 low (divide-by-2 only)	1	8	ns
8	$t_d(CLKINH-CLKO0H)$ Delay time, CLKIN/MXI high to CLK_OUT0 high (divide-by-2 only)	1	8	ns

(1) The reference points for the rise and fall transitions are measured at  $V_{OL\ MAX}$  and  $V_{OH\ MIN}$ .

(2)  $P = 1/CLK\_OUT0$  clock frequency in nanoseconds (ns). For example, when CLK\_OUT0 frequency is 27 MHz, use  $P = 37.04$  ns.

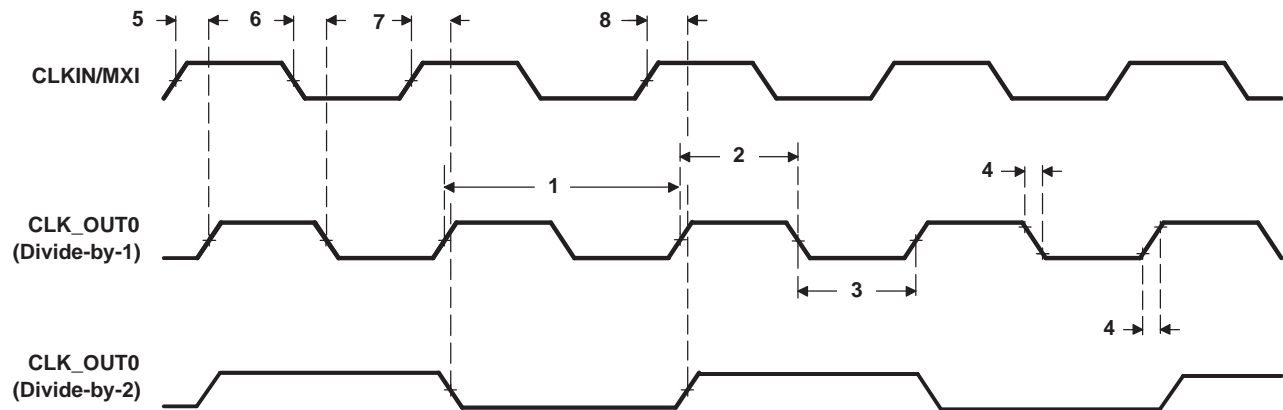
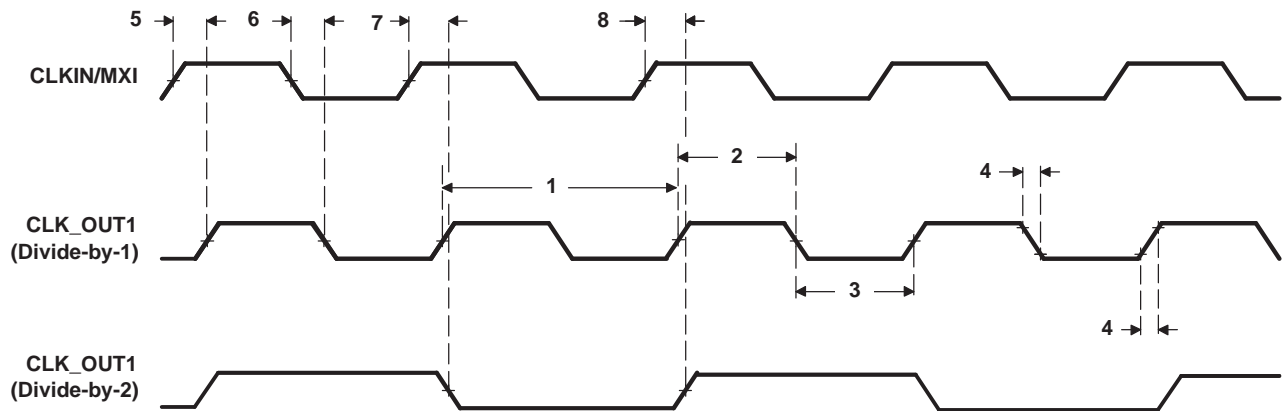

**Figure 6-16. CLK\_OUT0 Timing**

**Table 6-19. Switching Characteristics Over Recommended Operating Conditions for CLK\_OUT1<sup>(1)(2)</sup>**  
(see [Figure 6-17](#))

NO.	PARAMETER	MIN	MAX	UNIT
1	$t_C$ Cycle time, CLK_OUT1	41.667	83.33	
2	$t_{w(CLKOUT1H)}$ Pulse duration, CLK_OUT1 high	0.45P	0.55P	ns
3	$t_{w(CLKOUT1L)}$ Pulse duration, CLK_OUT1 low	0.45P	0.55P	ns
4	$t_t(CLKOUT1)$ Transition time, CLK_OUT1		0.05P	ns
5	$t_d(CLKINH-CLKO1H)$ Delay time, CLKIN/MXI high to CLK_OUT1 high (divide-by-1 only)	1	8	ns
6	$t_d(CLKINL-CLKO1L)$ Delay time, CLKIN/MXI low to CLK_OUT1 low (divide-by-1 only)	1	8	ns
7	$t_d(CLKINH-CLKO1L)$ Delay time, CLKIN/MXI high to CLK_OUT1 low (divide-by-2 only)	1	8	ns
8	$t_d(CLKINH-CLKO1H)$ Delay time, CLKIN/MXI high to CLK_OUT1 high (divide-by-2 only)	1	8	ns

- (1) The reference points for the rise and fall transitions are measured at  $V_{OL\ MAX}$  and  $V_{OH\ MIN}$ .  
 (2)  $P = 1/CLK\_OUT1$  clock frequency in nanoseconds (ns). For example, when CLK\_OUT1 frequency is 24 MHz, use  $P = 41.\bar{6}$  ns.



**Figure 6-17. CLK\_OUT1 Timing**

## **6.7 Interrupts**

The DM6446 device has a large number of interrupts to service the needs of its many peripherals and subsystems. Both the ARM and C64x+ are capable of servicing these interrupts. All of the device interrupts are routed to the ARM interrupt controller with only a limited set routed to the C64x+ interrupt controller. The interrupts can be selectively enabled or disabled in either of the controllers. In typical applications, the ARM handles most of the peripheral interrupts and grants control, to the C64x+, of interrupts that are relevant to DSP algorithms. Also, the ARM and DSP can communicate with each other through interrupts.

### **6.7.1 ARM CPU Interrupts**

The ARM9 CPU core supports 2 direct interrupts: FIQ and IRQ. The DM6446 ARM interrupt controller prioritizes up to 64 interrupt requests from various peripherals and subsystems, which are listed in [Table 6-20](#), and interrupts the ARM CPU. Each interrupt is programmable for up to 8 levels of priority. There are 6 levels for IRQ and 2 levels for FIQ. Interrupts at the same priority level are serviced in order by the ARM Interrupt Number, with the lowest number having the highest priority. [Table 6-21](#) shows the ARM interrupt controller registers and memory locations. For more details on ARM interrupt control, see the *Documentation Support* section of the *TMS320DM6446 DMSoC ARM Subsystem Reference Guide* (literature number [SPRUE14](#)).

**Table 6-20. DM6446 ARM Interrupts**

ARM INTERRUPT NUMBER	ACRONYM	SOURCE	ARM INTERRUPT NUMBER	ACRONYM	SOURCE
0	VDINT0	VPSS CCDC 0	32	TINT0	Timer 0 – TINT12
1	VDINT1	VPSS CCDC 1	33	TINT1	Timer 0 – TINT34
2	VDINT2	VPSS CCDC 2	34	TINT2	Timer 1 – TINT12
3	HISTINT	VPSS Histogram	35	TINT3	Timer 1 – TINT34
4	H3AINT	VPSS AE/AWB/AF	36	PWMINT0	PWM 0
5	PRVUINT	VPSS Previewer	37	PWMINT1	PWM 1
6	RSZINT	VPSS Resizer	38	PWMINT2	PWM 2
7	-	Reserved	39	I2CINT	I2C
8	VENCINT	VPSS VPBE	40	UARTINT0	UART 0
9	ASQINT	VICP Sqr (ARM int)	41	UARTINT1	UART 1
10	IMXINT	VICP IMX	42	UARTINT2	UART 2
11	VLCDINT	VICP VLCD	43	SPINT0	SPI
12	-	Reserved	44	SPINT1	SPI
13	EMACINT	EMAC Memory Controller	45	-	Reserved
14	-	Reserved	46	DSP2ARM0	DSP Controller to ARM 0
15	-	Reserved	47	DSP2ARM1	DSP Controller to ARM 1
16	EDMA3CC_INT0	EDMA CC Region 0	48	GPIO0	GPIO 0
17	EDMA3CC_ERRINT	EDMA CC Error	49	GPIO1	GPIO 1
18	EDMA3TC_ERRINT0	EDMA TC 0 Error	50	GPIO2	GPIO 2
19	EDMA3TC_ERRINT1	EDMA TC 1 Error	51	GPIO3	GPIO 3
20	PSCINT	PSC ALLINT	52	GPIO4	GPIO 4
21	-	Reserved	53	GPIO5	GPIO 5
22	IDEINT	ATA / IDE	54	GPIO6	GPIO 6
23	HPINT	HPI	55	GPIO7	GPIO 7
24	ASPXINT	ASP Transmit	56	GPIOBNK0	GPIO Bank 0
25	ASPRINT	ASP Receive	57	GPIOBNK1	GPIO Bank 1
26	MMCINT	MMC	58	GPIOBNK2	GPIO Bank 2
27	SDIOINT	SD	59	GPIOBNK3	GPIO Bank 3
28	-	Reserved	60	GPIOBNK4	GPIO Bank 4
29	DDRINT	DDR2 Memory Controller	61	COMMTX	ARMSS
30	EMIFAINT	EMIFA	62	COMMRX	ARMSS
31	VLQINT	VLYNQ	63	EMUINT	E2ICE

**Table 6-21. ARM Interrupt Controller Registers**

HEX ADDRESS	ACRONYM	REGISTER DESCRIPTION
0x01C4 8000	FIQ0	FIQ Interrupt Status 0 [Interrupt Status of INT[31:0] (If Mapped to FIQ)]
0x01C4 8004	FIQ1	FIQ Interrupt Status 1 [Interrupt Status of INT[63:32] (If Mapped to FIQ)]
0x01C4 8008	IRQ0	IRQ Interrupt Status 0 [Interrupt Status of INT[31:0] (If Mapped to IRQ)]
0x01C4 800C	IRQ1	IRQ Interrupt Status 1 [Interrupt Status of INT[63:32] (If Mapped to IRQ)]
0x01C4 8010	FIQENTRY	Entry Address [28:0] for Valid FIQ Interrupt
0x01C4 8014	IRQENTRY	Entry Address [28:0] for Valid IRQ Interrupt
0x01C4 8018	EINT0	Interrupt Enable Register 0
0x01C4 801C	EINT1	Interrupt Enable Register 1
0x01C4 8020	INCTL	Interrupt Operation Control Register
0x01C4 8024	EABASE	Interrupt Entry Table Base Address Register
0x01C4 8028 - 0x01C4 802F	-	Reserved
0x01C4 8030	INTPRI0	Interrupt 0-7 Priority Select
0x01C4 8034	INTPRI1	Interrupt 8-15 Priority Select
0x01C4 8038	INTPRI2	Interrupt 16-23 Priority Select
0x01C4 803C	INTPRI3	Interrupt 24-31 Priority Select
0x01C4 8040	INTPRI4	Interrupt 32-39 Priority Select
0x01C4 8044	INTPRI5	Interrupt 40-47 Priority Select
0x01C4 8048	INTPRI6	Interrupt 48-55 Priority Select
0x01C4 804C	INTPRI7	Interrupt 56-63 Priority Select
0x01C4 8050 - 0x01C4 83FF	-	Reserved



## 6.7.2 DSP Interrupts

The C64x+ DSP interrupt controller combines device events into 12 prioritized interrupts. The source for each of the 12 CPU interrupts is user programmable and is listed in [Table 6-22](#). Also, the interrupt controller controls the generation of the CPU exception, NMI, and emulation interrupts. [Table 6-23](#) summarizes the C64x+ interrupt controller registers and memory locations. For more details on DSP interrupt control, see the *Documentation Support* section of the *TMS320DM6446 DMSoC DSP Subsystem Reference Guide* (literature number [SPRUE15](#)).

**Table 6-22. DM6446 DSP Interrupts**

DSP INTERRUPT NUMBER	ACRONYM	SOURCE	DSP INTERRUPT NUMBER	ACRONYM	SOURCE
0	EVT0	C64x+ Int Ctl 0	64		Reserved
1	EVT1	C64x+ Int Ctl 1	65		Reserved
2	EVT2	C64x+ Int Ctl 2	66		Reserved
3	EVT3	C64x+ Int Ctl 3	67		Reserved
4	TINT0	Timer 0 – TINT12	68		Reserved
5	TINT1	Timer 0 – TINT34	69		Reserved
6	TINT2	Timer 1 – TINT12	70		Reserved
7	TINT3	Timer 1 – TINT34	71		Reserved
8		Reserved	72		Reserved
9	EMU_DTDMA	C64x+ EMC	73		Reserved
10		Reserved	74		Reserved
11	EMU_RTDXRX	C64x+ RTDX	75		Reserved
12	EMU_RTDXTX	C64x+ RTDX	76		Reserved
13	IDMAINT0	C64x+ EMC 0	77		Reserved
14	IDMAINT1	C64x+ EMC 1	78		Reserved
15		Reserved	79		Reserved
16	ARM2DSP0	ARM to DSP Controller 0	80		Reserved
17	ARM2DSP1	ARM to DSP Controller 1	81		Reserved
18	ARM2DSP2	ARM to DSP Controller 2	82		Reserved
19	ARM2DSP3	ARM to DSP Controller 3	83		Reserved
20		Reserved	84		Reserved
21		Reserved	85		Reserved
22		Reserved	86		Reserved
23		Reserved	87		Reserved
24		Reserved	88		Reserved
25		Reserved	89		Reserved
26		Reserved	90		Reserved
27		Reserved	91		Reserved
28		Reserved	92		Reserved
29		Reserved	93		Reserved
30		Reserved	94		Reserved
31		Reserved	95		Reserved
32		Reserved	96	INTERR	C64x+ Interrupt Controller Dropped CPU Interrupt Event
33		Reserved	97	EMC_IDMAERR	C64x+ EMC Invalid IDMA Parameters
34		Reserved	98		Reserved
35		Reserved	99		Reserved
36	EDMA3CC_INT1	EDMACC Interrupt Region 1	100		Reserved

**Table 6-22. DM6446 DSP Interrupts (continued)**

DSP INTERRUPT NUMBER	ACRONYM	SOURCE	DSP INTERRUPT NUMBER	ACRONYM	SOURCE
37	EDMA3CC_ERRINT	EDMA CC Error	101		Reserved
38	EDMA3TC_ERRINT0	EDMA TC0 Error	102		Reserved
39	EDMA3TC_ERRINT1	EDMA TC1 Error	103		Reserved
40	PSCINT	PSC ALLINT	104		Reserved
41		Reserved	105		Reserved
42		Reserved	106		Reserved
43		Reserved	107		Reserved
44		Reserved	108		Reserved
45		Reserved	109		Reserved
46		Reserved	110		Reserved
47		Reserved	111		Reserved
48	ASPXINT	ASP Transmit	112	PMC_ED	C64x+ PMC
49	ASPRINT	ASP Receive	113		Reserved
50		Reserved	114		Reserved
51		Reserved	115		Reserved
52		Reserved	116	UMCED1	C64x+ UMC 1
53		Reserved	117	UMCED2	C64x+ UMC 2
54		Reserved	118	PDCERR	C64x+ PDC
55		Reserved	119	PVCINT	C64x+ PDC
56		Reserved	120	PMCCMPA	C64x+ PMC
57		Reserved	121	PMCDMPA	C64x+ PMC
58		Reserved	122	DMCCMPA	C64x+ DMC
59		Reserved	123	DMCDMPA	C64x+ DMC
60		Reserved	124	UMCCMPA	C64x+ UMC
61		Reserved	125	UMCDMPA	C64x+ UMC
62		Reserved	126	EMCCMPA	C64x+ EMC
63		Reserved	127	EMCDMPA	C64x+ EMC

**Table 6-23. C64x+ Interrupt Controller Registers**

HEX ADDRESS	ACRONYM	REGISTER DESCRIPTION
0x0180 0000	EVTFLAG0	Event flag register 0
0x0180 0004	EVTFLAG1	Event flag register 1
0x0180 0008	EVTFLAG2	Event flag register 2
0x0180 000C	EVTFLAG3	Event flag register 3
0x0180 0020	EVTSET0	Event set register 0
0x0180 0024	EVTSET1	Event set register 1
0x0180 0028	EVTSET2	Event set register 2
0x0180 002C	EVTSET3	Event set register 3
0x0180 0040	EVTCLR0	Event clear register 0
0x0180 0044	EVTCLR1	Event clear register 1
0x0180 0048	EVTCLR2	Event clear register 2
0x0180 004C	EVTCLR3	Event clear register 3
0x0180 0080	EVTMASK0	Event mask register 0
0x0180 0084	EVTMASK1	Event mask register 1
0x0180 0088	EVTMASK2	Event mask register 2
0x0180 008C	EVTMASK3	Event mask register 3
0x0180 00A0	MEVTFLAG0	Masked event flag register 0
0x0180 00A4	MEVTFLAG1	Masked event flag register 1
0x0180 00A8	MEVTFLAG2	Masked event flag register 2
0x0180 00AC	MEVTFLAG3	Masked event flag register 3
0x0180 00C0	EXPMASK0	Exception mask register 0
0x0180 00C4	EXPMASK1	Exception mask register 1
0x0180 00C8	EXPMASK2	Exception mask register 2
0x0180 00CC	EXPMASK3	Exception mask register 3
0x0180 00E0	MEXPFLAG0	Masked exception flag register 0
0x0180 00E4	MEXPFLAG1	Masked exception flag register 1
0x0180 00E8	MEXPFLAG2	Masked exception flag register 2
0x0180 00EC	MEXPFLAG3	Masked exception flag register 3
0x0180 0104	INTMUX1	Interrupt mux register 1
0x0180 0108	INTMUX2	Interrupt mux register 2
0x0180 010C	INTMUX3	Interrupt mux register 3
0x0180 0140 - 0x0180 0144	-	Reserved
0x0180 0180	INTXSTAT	Interrupt exception status
0x0180 0184	INTXCLR	Interrupt exception clear
0x0180 0188	INTDMASK	Dropped interrupt mask register
0x0180 01C0	EVTASRT	Event assert register

### 6.7.3 ARM/DSP Communications Interrupts

The INTGEN register is used for generating interrupts between the ARM and DSP. The INTGEN register format is shown in Figure 6-18. Table 6-24 describes the register bit fields. The ARM may generate an interrupt to the DSP by setting one of the four INTDSP[3:0] bits or the INTNMI bit. The interrupt bit automatically self clears and the corresponding DSP[3:0]STAT or NMISTAT bit is automatically set to indicate that the interrupt was generated. After servicing the interrupt, the DSP clears the status bit by writing '0'. The ARM may poll the status bit to determine when the DSP has completed servicing the interrupt. The DSP may generate an interrupt to the ARM in the same manner using the INTARM[1:0] bits and monitor ARM interrupt servicing via the ARM[1:0]STAT bits.

Figure 6-18. INTGEN Register

31	30	29	28	27	24	23	22	21	20	19	17	16	
Reserved		ARM1 STAT	ARM0 STAT	Reserved			DSP3 STAT	DSP2 STAT	DSP1 STAT	DSP0 STAT	Reserved		NMI STAT
R-00		R/W-0	R/W-0	R-0000			R/W-0	R/W-0	R/W-0	R/W-0	R-000		R/W-0
15	14	13	12	11	8	7	6	5	4	3	1	0	
Reserved		INT ARM1	INT ARM0	Reserved			INT DSP3	INT DSP2	INT DSP1	INT DSP0	Reserved		INT NMI
R-00		R/W-0	R/W-0	R-0000			R/W-0	R/W-0	R/W-0	R/W-0	R-000		R/W-0

LEGEND: R = Read, W = Write, n = value at reset

Table 6-24. INTGEN Register Bit Fields Descriptions

Name	Description
ARM1STAT	DSP to ARM Int1 Status/Clear <sup>(1)</sup>
ARM0STAT	DSP to ARM Int0 Status/Clear <sup>(1)</sup>
DSP3STAT	ARM to DSP Int3 Status/Clear <sup>(1)</sup>
DSP2STAT	ARM to DSP Int2 Status/Clear <sup>(1)</sup>
DSP1STAT	ARM to DSP Int1 Status/Clear <sup>(1)</sup>
DSP0STAT	ARM to DSP Int0 Status/Clear <sup>(1)</sup>
NMISTAT	DSP NMI Status/Clear <sup>(1)</sup>
INTARM1	DSP to ARM Int1 Set <sup>(2)</sup>
INTARM0	DSP to ARM Int0 Set <sup>(2)</sup>
INTDSP3	ARM to DSP Int3 Set <sup>(2)</sup>
INTDSP2	ARM to DSP Int2 Set <sup>(2)</sup>
INTDSP1	ARM to DSP Int1 Set <sup>(2)</sup>
INTDSP0	ARM to DSP Int0 Set <sup>(2)</sup>
INTNMI	DSP NMI Set <sup>(2)</sup>

(1) Write '0' to clear. Writing '1' has no effect.

(2) Write '1' to generate the interrupt. The register bit automatically clears to a value of '0'. Writing a '0' has no effect.

## 6.8 General-Purpose Input/Output (GPIO)

The GPIO peripheral provides general-purpose pins that can be configured as either inputs or outputs. When configured as an output, a write to an internal register can control the state driven on the output pin. When configured as an input, the state of the input is detectable by reading the state of an internal register. In addition, the GPIO peripheral can produce CPU interrupts and EDMA events in different interrupt/event generation modes. The GPIO peripheral provides generic connections to external devices. The GPIO pins are grouped into banks of 16 pins per bank (i.e., bank 0 consists of GPIO [0:15]).

The DM6446 GPIO peripheral supports the following:

- Up to 54 1.8v GPIO pins, GPIO[0:53]
- Up to 17 3.3v GPIO pins, GPIO3V[0:16] (GPIO[54:70])
- Interrupts:
  - Up to 8 unique GPIO[0:7] interrupts from Bank 0
  - 5 GPIO bank (aggregated) interrupt signals from each of the 5 banks of GPIOs
  - Interrupts can be triggered by rising and/or falling edge, specified for each interrupt capable GPIO signal
- DMA events:
  - Up to 8 unique GPIO DMA events from Bank 0
  - 5 GPIO bank (aggregated) DMA event signals from each of the 5 banks of GPIOs
- Set/clear functionality: Firmware writes 1 to corresponding bit position(s) to set or to clear GPIO signal(s). This allows multiple firmware processes to toggle GPIO output signals without critical section protection (disable interrupts, program GPIO, re-enable interrupts, to prevent context switching to another process during GPIO programming).
- Separate Input/Output registers
- Output register in addition to set/clear so that, if preferred by firmware, some GPIO output signals can be toggled by direct write to the output register(s).
- Output register, when read, reflects output drive status. This, in addition to the input register reflecting pin status and open-drain I/O cell, allows wired logic be implemented.

The memory map for the GPIO registers is shown in [Table 6-25](#). For more detailed information on GPIOs, see the *Documentation Support* section for the General-Purpose Input/Output (GPIO) Reference Guide.

### 6.8.1 GPIO Peripheral Register Description(s)

**Table 6-25. GPIO Registers**

HEX ADDRESS RANGE	ACRONYM	REGISTER NAME
0x01C6 7000	PID	Peripheral Identification Register
0x01C6 7004	-	Reserved
0x01C6 7008	BINTEN	GPIO interrupt per-bank enable
<b>GPIO Banks 0 and 1</b>		
0x01C6 700C	-	Reserved
0x01C6 7010	DIR01	GPIO Banks 0 and 1 Direction Register (GPIO[0:31])
0x01C6 7014	OUT_DATA01	GPIO Banks 0 and 1 Output Data Register (GPIO[0:31])
0x01C6 7018	SET_DATA01	GPIO Banks 0 and 1 Set Data Register (GPIO[0:31])
0x01C6 701C	CLR_DATA01	GPIO Banks 0 and 1 Clear data for banks 0 and 1 (GPIO[0:31])
0x01C6 7020	IN_DATA01	GPIO Banks 0 and 1 Input Data Register (GPIO[0:31])
0x01C6 7024	SET_RIS_TRIG01	GPIO Banks 0 and 1 Set Rising Edge Interrupt Register (GPIO[0:31])
0x01C6 7028	CLR_RIS_TRIG01	GPIO Banks 0 and 1 Clear Rising Edge Interrupt Register (GPIO[0:31])
0x01C6 702C	SET_FAL_TRIG01	GPIO Banks 0 and 1 Set Falling Edge Interrupt Register (GPIO[0:31])
0x01C6 7030	CLR_FAL_TRIG01	GPIO Banks 0 and 1 Clear Falling Edge Interrupt Register (GPIO[0:31])
0x01C6 7034	INSTAT01	GPIO Banks 0 and 1 Interrupt Status Register (GPIO[0:31])
<b>GPIO Banks 2 and 3</b>		
0x01C6 7038	DIR23	GPIO Banks 2 and 3 Direction Register (GPIO[32:63])
0x01C6 703C	OUT_DATA23	GPIO Banks 2 and 3 Output Data Register (GPIO[32:63])
0x01C6 7040	SET_DATA23	GPIO Banks 2 and 3 Set Data Register (GPIO[32:63])
0x01C6 7044	CLR_DATA23	GPIO Banks 2 and 3 Clear Data Register (GPIO[32:63])
0x01C6 7048	IN_DATA23	GPIO Banks 2 and 3 Input Data Register (GPIO[32:63])
0x01C6 704C	SET_RIS_TRIG23	GPIO Banks 2 and 3 Set Rising Edge Interrupt Register (GPIO[32:63])
0x01C6 7050	CLR_RIS_TRIG23	GPIO Banks 2 and 3 Clear Rising Edge Interrupt Register (GPIO[32:63])
0x01C6 7054	SET_FAL_TRIG23	GPIO Banks 2 and 3 Set Falling Edge Interrupt Register (GPIO[32:63])
0x01C6 7058	CLR_FAL_TRIG23	GPIO Banks 2 and 3 Clear Falling Edge Interrupt Register (GPIO[32:63])
0x01C6 705C	INSTAT23	GPIO Banks 2 and 3 Interrupt Status Register (GPIO[32:63])
<b>GPIO Bank 4</b>		
0x01C6 7060	DIR4	GPIO Bank 4 Direction Register (GPIO[64:70])
0x01C6 7064	OUT_DATA4	GPIO Bank 4 Output Data Register (GPIO[64:70])
0x01C6 7068	SET_DATA4	GPIO Bank 4 Set Data Register (GPIO[64:70])
0x01C6 706C	CLR_DATA4	GPIO Bank 4 Clear Data Register (GPIO[64:70])
0x01C6 7070	IN_DATA4	GPIO Bank 4 Input Data Register (GPIO[64:70])
0x01C6 7074	SET_RIS_TRIG4	GPIO Bank 4 Set Rising Edge Interrupt Register (GPIO[64:70])
0x01C6 7078	CLR_RIS_TRIG4	GPIO Bank 4 Clear Rising Edge Interrupt Register (GPIO[64:70])
0x01C6 707C	SET_FAL_TRIG4	GPIO Bank 4 Set Falling Edge Interrupt Register (GPIO[64:70])
0x01C6 7080	CLR_FAL_TRIG4	GPIO Bank 4 Clear Falling Edge Interrupt Register (GPIO[64:70])
0x01C6 7084	INSTAT4	GPIO Bank 4 Interrupt Status Register (GPIO[64:70])
0x01C6 7088 - 0x01C6 7FFF	-	Reserved

### 6.8.2 GPIO Peripheral Input/Output Electrical Data/Timing

Table 6-26. Timing Requirements for GPIO Inputs<sup>(1)</sup> (see Figure 6-19)

NO.		MIN	MAX	UNIT
1	$t_{w(GPIH)}$ Pulse duration, GPIx high	52		ns
2	$t_{w(GPIL)}$ Pulse duration, GPIx low	52		ns

(1) The pulse width given is sufficient to generate a CPU interrupt or an EDMA event. However, if a user wants to have DM6446 recognize the GPIx changes through software polling of the GPIO register, the GPIx duration must be extended to allow DM6446 enough time to access the GPIO register through the internal bus.

Table 6-27. Switching Characteristics Over Recommended Operating Conditions for GPIO Outputs (see Figure 6-19)

NO.	PARAMETER	MIN	MAX	UNIT
3	$t_{w(GPOH)}$ Pulse duration, GPOx high	26 <sup>(1)</sup>		ns
4	$t_{w(GPOL)}$ Pulse duration, GPOx low	26 <sup>(1)</sup>		ns

(1) This parameter value should not be used as a maximum performance specification. Actual performance of back-to-back accesses of the GPIO is dependent upon internal bus activity.

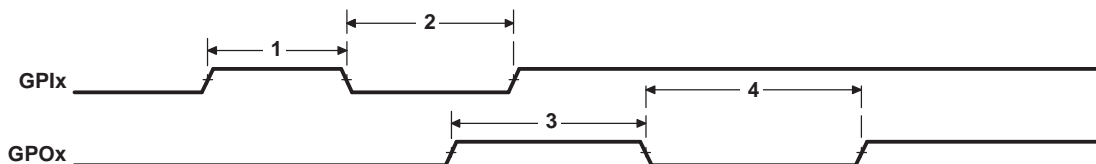

Figure 6-19. GPIO Port Timing

### 6.8.3 GPIO Peripheral External Interrupts Electrical Data/Timing

Table 6-28. Timing Requirements for External Interrupts<sup>(1)</sup> (see Figure 6-20)

NO.		MIN	MAX	UNIT
1	$t_{w(ILOW)}$ Width of the external interrupt pulse low	52		ns
2	$t_{w(IHIGH)}$ Width of the external interrupt pulse high	52		ns

(1) The pulse width given is sufficient to generate an interrupt or an EDMA event. However, if a user wants to have DM6446 recognize the GPIO changes through software polling of the GPIO register, the GPIO duration must be extended to allow DM6446 enough time to access the GPIO register through the internal bus.

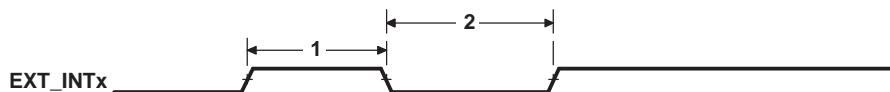

Figure 6-20. GPIO External Interrupt Timing

## 6.9 Enhanced Direct Memory Access (EDMA) Controller

The EDMA controller handles all data transfers between memories and the device slave peripherals on the DM6446 device. These data transfers include cache servicing, non-cacheable memory accesses, user-programmed data transfers, and host accesses. These are summarized as follows:

- Transfer to/from on-chip memories
  - Coprocessor shared memory
  - DSP L1D memory
  - DSP L2 memory
  - ARM program/data RAM
- Transfer to/from external storage
  - DDR2 SDRAM
  - NAND flash
  - Asynchronous EMIF
  - Smart Media, SD, MMC, xD media storage
  - ATA/CF
- Transfer to/from peripherals/hosts
  - VLYNQ
  - ASP
  - SPI
  - PWM
  - UART

The EDMA controller supports two addressing modes: constant addressing mode and increment addressing mode. On the DM6446 device, constant addressing mode is not supported by any peripheral or internal memory. For more information on these two addressing modes, see the *TMS320DM644x DMSoC Enhanced Direct Memory Access (EDMA) Controller User's Guide* (literature number [SPRUE23](#)).

### 6.9.1 EDMA Channel Synchronization Events

The EDMA supports up to 64 EDMA channels which service peripheral devices and external memory. [Table 6-29](#) lists the source of EDMA synchronization events associated with each of the programmable EDMA channels. For the DM6446 device, the association of an event to a channel is fixed; each of the EDMA channels has one specific event associated with it. These specific events are captured in the EDMA event registers (ER, ERH) even if the events are disabled by the EDMA event enable registers (EER, EERH). For more detailed information on the EDMA module and how EDMA events are enabled, captured, processed, linked, chained, and cleared, etc., see the *Document Support* section of the *TMS320DM644x DMSoC Enhanced Direct Memory Access (EDMA) Controller User's Guide* (literature number [SPRUE23](#)).

**Table 6-29. DM6446 EDMA Channel Synchronization Events<sup>(1)</sup>**

EDMA CHANNEL	EVENT NAME	EVENT DESCRIPTION
0-1		Reserved
2	XEVT	ASP Transmit Event
3	REVT	ASP Receive Event
4	HISTEVT	VPSS Histogram Event
5	H3AEVT	VPSS H3A Event
6	PRVUEVT	VPSS Previewer Event
7	RSZEVT	VPSS Resizer Event

(1) In addition to the events shown in this table, each of the 64 channels can also be synchronized with the transfer completion or alternate transfer completion events. For more detailed information on EDMA event-transfer chaining, see the *Document Support* section of the *TMS320DM644x DMSoC Enhanced Direct Memory Access (EDMA) Controller User's Guide* (literature number [SPRUE23](#)).



**Table 6-29. DM6446 EDMA Channel Synchronization Events (continued)**

EDMA CHANNEL	EVENT NAME	EVENT DESCRIPTION
8	IMXINT	VICP Interrupt
9	VLCDINT	VICP VLCD Interrupt
10	ASQINT	VICP ASQ Interrupt
11	DSQINT	VICP DSQ Interrupt
12-15		Reserved
16	SPIXEVT	SPI Transmit Event
17	SPIREVT	SPI Receive Event
18	URXEVT0	UART 0 Receive Event
19	UTXEVT0	UART 0 Transmit Event
20	URXEVT1	UART 1 Receive Event
21	UTXEVT1	UART 1 Transmit Event
22	URXEVT2	UART 2 Receive Event
23	UTXEVT2	UART 2 Transmit Event
24		Reserved
25		Reserved
26	MMCRXEVT	MMC Receive Event
27	MMCTXEVT	MMC Transmit Event
28	I2CREVT	I2C Receive Event
29	I2CXEVT	I2C Transmit Event
30-31		Reserved
32	GPINT0	GPIO 0 Interrupt
33	GPINT1	GPIO 1 Interrupt
34	GPINT2	GPIO 2 Interrupt
35	GPINT3	GPIO 3 Interrupt
36	GPINT4	GPIO 4 Interrupt
37	GPINT5	GPIO 5 Interrupt
38	GPINT6	GPIO 6 Interrupt
39	GPINT7	GPIO 7 Interrupt
40	GPBNKINT0	GPIO Bank 0 Interrupt
41	GPBNKINT1	GPIO Bank 1 Interrupt
42	GPBNKINT2	GPIO Bank 2 Interrupt
43	GPBNKINT3	GPIO Bank 3 Interrupt
44	GPBNKINT4	GPIO Bank 4 Interrupt
45-47		Reserved
48	TINT0	Timer 0 Interrupt
49	TINT1	Timer 1 Interrupt
50	TINT2	Timer 2 Interrupt
51	TINT3	Timer 3 Interrupt
52	PWM0	PWM 0 Event
53	PWM1	PWM 1 Event
54	PWM2	PWM 2 Event
55-63		Reserved

## 6.9.2 EDMA Peripheral Register Descriptions

Table 6-30 lists the EDMA registers, their corresponding acronyms, and DM6446 device memory locations.

**Table 6-30. DM6446 EDMA Registers**

HEX ADDRESS	ACRONYM	REGISTER NAME
<b>Channel Controller Registers</b>		
0x01c0 0000 - 0x01c0 0003		Reserved
0x01c0 0004	CCCFG	EDMA3CC Configuration Register
0x01c0 0008 - 0x01c0 01FF		Reserved
<b>Global Registers</b>		
0x01c0 0200	QCHMAP0	QDMA Channel 0 Mapping to PaRAM Register
0x01c0 0204	QCHMAP1	QDMA Channel 1 Mapping to PaRAM Register
0x01c0 0208	QCHMAP2	QDMA Channel 2 Mapping to PaRAM Register
0x01c0 020C	QCHMAP3	QDMA Channel 3 Mapping to PaRAM Register
0x01c0 0210	QCHMAP4	QDMA Channel 4 Mapping to PaRAM Register
0x01c0 0214	QCHMAP5	QDMA Channel 5 Mapping to PaRAM Register
0x01c0 0218	QCHMAP6	QDMA Channel 6 Mapping to PaRAM Register
0x01c0 021C	QCHMAP7	QDMA Channel 7 Mapping to PaRAM Register
0x01c0 0240	DMAQNUM0	DMA Queue Number Register 0 (Channels 00 to 07)
0x01c0 0244	DMAQNUM1	DMA Queue Number Register 1 (Channels 08 to 15)
0x01c0 0248	DMAQNUM2	DMA Queue Number Register 2 (Channels 16 to 23)
0x01c0 024C	DMAQNUM3	DMA Queue Number Register 3 (Channels 24 to 31)
0x01c0 0250	DMAQNUM4	DMA Queue Number Register 4 (Channels 32 to 39)
0x01c0 0254	DMAQNUM5	DMA Queue Number Register 5 (Channels 40 to 47)
0x01c0 0258	DMAQNUM6	DMA Queue Number Register 6 (Channels 48 to 55)
0x01c0 025C	DMAQNUM7	DMA Queue Number Register 7 (Channels 56 to 63)
0x01c0 0260	QDMAQNUM	CC QDMA Queue Number
0x01c0 0264 - 0x01c0 0283	–	Reserved
0x01c0 0284	QUEPRI	Queue Priority Register
0x01c0 0288 - 0x01c0 02FF	–	Reserved
0x01c0 0300	EMR	Event Missed Register
0x01c0 0304	EMRH	Event Missed Register High
0x01c0 0308	EMCR	Event Missed Clear Register
0x01c0 030C	EMCRH	Event Missed Clear Register High
0x01c0 0310	QEMR	QDMA Event Missed Register
0x01c0 0314	QEMCR	QDMA Event Missed Clear Register
0x01c0 0318	CCERR	EDMA3CC Error Register
0x01c0 031C	CCERRCLR	EDMA3CC Error Clear Register
0x01c0 0320	EEVAL	Error Evaluate Register
0x01c0 0340	DRAE0	DMA Region Access Enable Register for Region 0
0x01c0 0344	DRAEH0	DMA Region Access Enable Register High for Region 0
0x01c0 0348	DRAE1	DMA Region Access Enable Register for Region 1
0x01c0 034C	DRAEH1	DMA Region Access Enable Register High for Region 1
0x01c0 0350	DRAE2	DMA Region Access Enable Register for Region 2
0x01c0 0354	DRAEH2	DMA Region Access Enable Register High for Region 2
0x01c0 0358	DRAE3	DMA Region Access Enable Register for Region 3
0x01c0 035C	DRAEH3	DMA Region Access Enable Register High for Region 3
0x01c0 0360 - 0x01c0 037C	–	Reserved

**Table 6-30. DM6446 EDMA Registers (continued)**

HEX ADDRESS	ACRONYM	REGISTER NAME
0x01c0 0380	QRAE0	QDMA Region Access Enable Register for Region 0
0x01c0 0384	QRAE1	QDMA Region Access Enable Register for Region 1
0x01c0 0388	QRAE2	QDMA Region Access Enable Register for Region 2
0x01c0 038C	QRAE3	QDMA Region Access Enable Register for Region 3
0x01c0 0390 - 0x01c0 039C	–	Reserved
0x01c0 0400	Q0E0	Event Q0 Entry 0 Register
0x01c0 0404	Q0E1	Event Q0 Entry 1 Register
0x01c0 0408	Q0E2	Event Q0 Entry 2 Register
0x01c0 040C	Q0E3	Event Q0 Entry 3 Register
0x01c0 0410	Q0E4	Event Q0 Entry 4 Register
0x01c0 0414	Q0E5	Event Q0 Entry 5 Register
0x01c0 0418	Q0E6	Event Q0 Entry 6 Register
0x01c0 041C	Q0E7	Event Q0 Entry 7 Register
0x01c0 0420	Q0E8	Event Q0 Entry 8 Register
0x01c0 0424	Q0E9	Event Q0 Entry 9 Register
0x01c0 0428	Q0E10	Event Q0 Entry 10 Register
0x01c0 042C	Q0E11	Event Q0 Entry 11 Register
0x01c0 0430	Q0E12	Event Q0 Entry 12 Register
0x01c0 0434	Q0E13	Event Q0 Entry 13 Register
0x01c0 0438	Q0E14	Event Q0 Entry 14 Register
0x01c0 043C	Q0E15	Event Q0 Entry 15 Register
0x01c0 0440	Q1E0	Event Q1 Entry 0 Register
0x01c0 0444	Q1E1	Event Q1 Entry 1 Register
0x01c0 0448	Q1E2	Event Q1 Entry 2 Register
0x01c0 044C	Q1E3	Event Q1 Entry 3 Register
0x01c0 0450	Q1E4	Event Q1 Entry 4 Register
0x01c0 0454	Q1E5	Event Q1 Entry 5 Register
0x01c0 0458	Q1E6	Event Q1 Entry 6 Register
0x01c0 045C	Q1E7	Event Q1 Entry 7 Register
0x01c0 0460	Q1E8	Event Q1 Entry 8 Register
0x01c0 0464	Q1E9	Event Q1 Entry 9 Register
0x01c0 0468	Q1E10	Event Q1 Entry 10 Register
0x01c0 046C	Q1E11	Event Q1 Entry 11 Register
0x01c0 0470	Q1E12	Event Q1 Entry 12 Register
0x01c0 0474	Q1E13	Event Q1 Entry 13 Register
0x01c0 0478	Q1E14	Event Q1 Entry 14 Register
0x01c0 047C	Q1E15	Event Q1 Entry 15 Register
0x01c0 0480 - 0x01c0 05FF		Reserved
0x01c0 0600	QSTAT0	Queue 0 Status Register
0x01c0 0604	QSTAT1	Queue 1 Status Register
0x01c0 0608 - 0x01c0 061F		Reserved
0x01c0 0620	QWMTHRA	Queue Watermark Threshold A Register for Q[3:0]
0x01c0 0624	–	Reserved
0x01c0 0640	CCSTAT	EDMA3CC Status Register
0x01c0 0644 - 0x01c0 0FFF		Reserved

**Table 6-30. DM6446 EDMA Registers (continued)**

HEX ADDRESS	ACRONYM	REGISTER NAME
<b>Global Channel Registers</b>		
0x01c0 1000	ER	Event Register
0x01c0 1004	ERH	Event Register High
0x01c0 1008	ECR	Event Clear Register
0x01c0 100C	ECRH	Event Clear Register High
0x01c0 1010	ESR	Event Set Register
0x01c0 1014	ESRH	Event Set Register High
0x01c0 1018	CER	Chained Event Register
0x01c0 101C	CERH	Chained Event Register High
0x01c0 1020	EER	Event Enable Register
0x01c0 1024	EERH	Event Enable Register High
0x01c0 1028	EECR	Event Enable Clear Register
0x01c0 102C	EECRH	Event Enable Clear Register High
0x01c0 1030	EESR	Event Enable Set Register
0x01c0 1034	EESRH	Event Enable Set Register High
0x01c0 1038	SER	Secondary Event Register
0x01c0 103C	SERH	Secondary Event Register High
0x01c0 1040	SECR	Secondary Event Clear Register
0x01c0 1044	SECRH	Secondary Event Clear Register High
0x01c0 1048 - 0x01c0 104F		Reserved
0x01c0 1050	IER	Interrupt Enable Register
0x01c0 1054	IERH	Interrupt Enable Register High
0x01c0 1058	IECR	Interrupt Enable Clear Register
0x01c0 105C	IECRH	Interrupt Enable Clear Register High
0x01c0 1060	IESR	Interrupt Enable Set Register
0x01c0 1064	IESRH	Interrupt Enable Set Register High
0x01c0 1068	IPR	Interrupt Pending Register
0x01c0 106C	IPRH	Interrupt Pending Register High
0x01c0 1070	ICR	Interrupt Clear Register
0x01c0 1074	ICRH	Interrupt Clear Register High
0x01c0 1078	IEVAL	Interrupt Evaluate Register
0x01c0 1080	QER	QDMA Event Register
0x01c0 1084	QEER	QDMA Event Enable Register
0x01c0 1088	QEECR	QDMA Event Enable Clear Register
0x01c0 108C	QEESR	QDMA Event Enable Set Register
0x01c0 1090	QSER	QDMA Secondary Event Register
0x01c0 1094	QSECR	QDMA Secondary Event Clear Register
0x01c0 1098 - 0x01c0 1FFF		Reserved
<b>Shadow Region 0 Channel Registers</b>		
0x01c0 2000	ER	Event Register
0x01c0 2004	ERH	Event Register High
0x01c0 2008	ECR	Event Clear Register
0x01c0 200C	ECRH	Event Clear Register High
0x01c0 2010	ESR	Event Set Register
0x01c0 2014	ESRH	Event Set Register High
0x01c0 2018	CER	Chained Event Register
0x01c0 201C	CERH	Chained Event Register High

**Table 6-30. DM6446 EDMA Registers (continued)**

HEX ADDRESS	ACRONYM	REGISTER NAME
0x01c0 2020	EER	Event Enable Register
0x01c0 2024	EERH	Event Enable Register High
0x01c0 2028	EECR	Event Enable Clear Register
0x01c0 202C	EECRH	Event Enable Clear Register High
0x01c0 2030	EESR	Event Enable Set Register
0x01c0 2034	EESRH	Event Enable Set Register High
0x01c0 2038	SER	Secondary Event Register
0x01c0 203C	SERH	Secondary Event Register High
0x01c0 2040	SECR	Secondary Event Clear Register
0x01c0 2044	SECRH	Secondary Event Clear Register High
0x01c0 2048 - 0x01c0 204C	-	Reserved
0x01c0 2050	IER	Interrupt Enable Register
0x01c0 2054	IERH	Interrupt Enable Register High
0x01c0 2058	IECR	Interrupt Enable Clear Register
0x01c0 205C	IECRH	Interrupt Enable Clear Register High
0x01c0 2060	IESR	Interrupt Enable Set Register
0x01c0 2064	IESRH	Interrupt Enable Set Register High
0x01c0 2068	IPR	Interrupt Pending Register
0x01c0 206C	IPRH	Interrupt Pending Register High
0x01c0 2070	ICR	Interrupt Clear Register
0x01c0 2074	ICRH	Interrupt Clear Register High
0x01c0 2078	IEVAL	Interrupt Evaluate Register
0x01c0 207C	-	Reserved
0x01c0 2080	QER	QDMA Event Register
0x01c0 2084	QEER	QDMA Event Enable Register
0x01c0 2088	QEECR	QDMA Event Enable Clear Register
0x01c0 208C	QEESR	QDMA Event Enable Set Register
0x01c0 2090	QSER	QDMA Secondary Event Register
0x01c0 2094	QSECR	QDMA Secondary Event Clear Register
0x01c0 2098 - 0x01c0 21FC	-	Reserved
<b>Shadow Region 1 Channel Registers</b>		
0x01c0 2200	ER	Event Register
0x01c0 2204	ERH	Event Register High
0x01c0 2208	ECR	Event Clear Register
0x01c0 220C	ECRH	Event Clear Register High
0x01c0 2210	ESR	Event Set Register
0x01c0 2214	ESRH	Event Set Register High
0x01c0 2218	CER	Chained Event Register
0x01c0 221C	CERH	Chained Event Register High
0x01c0 2220	EER	Event Enable Register
0x01c0 2224	EERH	Event Enable Register High
0x01c0 2228	EECR	Event Enable Clear Register
0x01c0 222C	EECRH	Event Enable Clear Register High
0x01c0 2230	EESR	Event Enable Set Register
0x01c0 2234	EESRH	Event Enable Set Register High
0x01c0 2238	SER	Secondary Event Register
0x01c0 223C	SERH	Secondary Event Register High

**Table 6-30. DM6446 EDMA Registers (continued)**

HEX ADDRESS	ACRONYM	REGISTER NAME
0x01c0 2240	SECR	Secondary Event Clear Register
0x01c0 2244	SECRH	Secondary Event Clear Register High
0x01c0 2248 - 0x01c0 224C	-	Reserved
0x01c0 2250	IER	Interrupt Enable Register
0x01c0 2254	IERH	Interrupt Enable Register High
0x01c0 2258	IECR	Interrupt Enable Clear Register
0x01c0 225C	IECRH	Interrupt Enable Clear Register High
0x01c0 2260	IESR	Interrupt Enable Set Register
0x01c0 2264	IESRH	Interrupt Enable Set Register High
0x01c0 2268	IPR	Interrupt Pending Register
0x01c0 226C	IPRH	Interrupt Pending Register High
0x01c0 2270	ICR	Interrupt Clear Register
0x01c0 2274	ICRH	Interrupt Clear Register High
0x01c0 2278	IEVAL	Interrupt Evaluate Register
0x01c0 227C	-	Reserved
0x01c0 2280	QER	QDMA Event Register
0x01c0 2284	QEER	QDMA Event Enable Register
0x01c0 2288	QEECR	QDMA Event Enable Clear Register
0x01c0 228C	QEESR	QDMA Event Enable Set Register
0x01c0 2290	QSER	QDMA Secondary Event Register
0x01c0 2294	QSECR	QDMA Secondary Event Clear Register
0x01c0 2298 - 0x01c0 23FC	-	Reserved
<b>Shadow Region 2 Channel Registers</b>		
0x01c0 2400	ER	Event Register
0x01c0 2404	ERH	Event Register High
0x01c0 2408	ECR	Event Clear Register
0x01c0 240C	ECRH	Event Clear Register High
0x01c0 2410	ESR	Event Set Register
0x01c0 2414	ESRH	Event Set Register High
0x01c0 2418	CER	Chained Event Register
0x01c0 241C	CERH	Chained Event Register High
0x01c0 2420	EER	Event Enable Register
0x01c0 2424	EERH	Event Enable Register High
0x01c0 2428	EECR	Event Enable Clear Register
0x01c0 242C	EECRH	Event Enable Clear Register High
0x01c0 2430	EESR	Event Enable Set Register
0x01c0 2434	EESRH	Event Enable Set Register High
0x01c0 2438	SER	Secondary Event Register
0x01c0 243C	SERH	Secondary Event Register High
0x01c0 2440	SECR	Secondary Event Clear Register
0x01c0 2444	SECRH	Secondary Event Clear Register High
0x01c0 2448 - 0x01c0 244C	-	Reserved
0x01c0 2450	IER	Interrupt Enable Register
0x01c0 2454	IERH	Interrupt Enable Register High
0x01c0 2458	IECR	Interrupt Enable Clear Register
0x01c0 245C	IECRH	Interrupt Enable Clear Register High
0x01c0 2460	IESR	Interrupt Enable Set Register

**Table 6-30. DM6446 EDMA Registers (continued)**

HEX ADDRESS	ACRONYM	REGISTER NAME
0x01c0 2464	IESRH	Interrupt Enable Set Register High
0x01c0 2468	IPR	Interrupt Pending Register
0x01c0 246C	IPRH	Interrupt Pending Register High
0x01c0 2470	ICR	Interrupt Clear Register
0x01c0 2474	ICRH	Interrupt Clear Register High
0x01c0 2478	IEVAL	Interrupt Evaluate Register
0x01c0 247C	-	Reserved
0x01c0 2480	QER	QDMA Event Register
0x01c0 2484	QEER	QDMA Event Enable Register
0x01c0 2488	QEECR	QDMA Event Enable Clear Register
0x01c0 248C	QEESR	QDMA Event Enable Set Register
0x01c0 2490	QSER	QDMA Secondary Event Register
0x01c0 2494	QSECR	QDMA Secondary Event Clear Register
0x01c0 2498 - 0x01c0 25FC	-	Reserved
<b>Shadow Region 3 Channel Registers</b>		
0x01c0 2600	ER	Event Register
0x01c0 2604	ERH	Event Register High
0x01c0 2608	ECR	Event Clear Register
0x01c0 260C	ECRH	Event Clear Register High
0x01c0 2610	ESR	Event Set Register
0x01c0 2614	ESRH	Event Set Register High
0x01c0 2618	CER	Chained Event Register
0x01c0 261C	CERH	Chained Event Register High
0x01c0 2620	EER	Event Enable Register
0x01c0 2624	EERH	Event Enable Register High
0x01c0 2628	EECR	Event Enable Clear Register
0x01c0 262C	EECRH	Event Enable Clear Register High
0x01c0 2630	EESR	Event Enable Set Register
0x01c0 2634	EESRH	Event Enable Set Register High
0x01c0 2638	SER	Secondary Event Register
0x01c0 263C	SERH	Secondary Event Register High
0x01c0 2640	SECR	Secondary Event Clear Register
0x01c0 2644	SECRH	Secondary Event Clear Register High
0x01c0 2648 - 0x01c0 264C	-	Reserved
0x01c0 2650	IER	Interrupt Enable Register
0x01c0 2654	IERH	Interrupt Enable Register High
0x01c0 2658	IECR	Interrupt Enable Clear Register
0x01c0 265C	IECRH	Interrupt Enable Clear Register High
0x01c0 2660	IESR	Interrupt Enable Set Register
0x01c0 2664	IESRH	Interrupt Enable Set Register High
0x01c0 2668	IPR	Interrupt Pending Register
0x01c0 266C	IPRH	Interrupt Pending Register High
0x01c0 2670	ICR	Interrupt Clear Register
0x01c0 2674	ICRH	Interrupt Clear Register High
0x01c0 2678	IEVAL	Interrupt Evaluate Register
0x01c0 267C	-	Reserved
0x01c0 2680	QER	QDMA Event Register

**Table 6-30. DM6446 EDMA Registers (continued)**

HEX ADDRESS	ACRONYM	REGISTER NAME
0x01c0 2684	QEER	QDMA Event Enable Register
0x01c0 2688	QEECR	QDMA Event Enable Clear Register
0x01c0 268C	QEESR	QDMA Event Enable Set Register
0x01c0 2690	QSER	QDMA Secondary Event Register
0x01c0 2694	QSECR	QDMA Secondary Event Clear Register
0x01c0 2698 - 0x01c0 27FC	-	Reserved
0x01c0 2800 - 0x01c0 29FC	-	Reserved
0x01c0 2A00 - 0x01c0 2BFC	-	Reserved
0x01c0 2C00 - 0x01c0 2DFC	-	Reserved
0x01c0 2E00 - 0x01c0 2FFC	-	Reserved
0x01c0 2FFD - 0x01c0 3FFF	-	Reserved
0x01c0 4000 - 0x01c0 4FFF	-	Parameter Set RAM (see <a href="#">Table 6-31</a> )
0x01c0 5000 - 0x01c0 7FFF	-	Reserved
0x01c0 8000 - 0x01c0 FFFF	-	Reserved
<b>Transfer Controller 0 Registers</b>		
0x01c1 0000	-	Reserved
0x01c1 0004	TCCFG	EDMA3 TC0 Configuration Register
0x01c1 0008 - 0x01c1 00FF	-	Reserved
0x01c1 0100	TCSTAT	EDMA3 TC0 Channel Status Register
0x01c1 0104 - 0x01c1 0110	-	Reserved
0x01c1 0114 - 0x01c1 011F	-	Reserved
0x01c1 0120	ERRSTAT	EDMA3 TC0 Error Status Register
0x01c1 0124	ERREN	EDMA3 TC0 Error Enable Register
0x01c1 0128	ERRCLR	EDMA3 TC0 Error Clear Register
0x01c1 012C	ERRDET	EDMA3 TC0 Error Details Register
0x01c1 0130	ERRCMD	EDMA3 TC0 Error Interrupt Command Register
0x01c1 0134 - 0x01c1 013F	-	Reserved
0x01c1 0140	RDRATE	EDMA3 TC0 Read Rate Register
0x01c1 0144 - 0x01c1 01FF	-	Reserved
0x01c1 0200 - 0x01c1 023F	-	Reserved
0x01c1 0240	SAOPT	EDMA3 TC0 Source Active Options Register
0x01c1 0244	SASRC	EDMA3 TC0 Source Active Source Address Register
0x01c1 0248	SACNT	EDMA3 TC0 Source Active Count Register
0x01c1 024C	SADST	EDMA3 TC0 Source Active Destination Address Register
0x01c1 0250	SABIDX	EDMA3 TC0 Source Active Source B-Index Register
0x01c1 0254	SAMPPRXY	EDMA3 TC0 Source Active Memory Protection Proxy Register
0x01c1 0258	SACNTRLD	EDMA3 TC0 Source Active Count Reload Register
0x01c1 025C	SASRCBREF	EDMA3 TC0 Source Active Source Address B-Reference Register
0x01c1 0260	SADSTBREF	EDMA3 TC0 Source Active Destination Address B-Reference Register
0x01c1 0264 - 0x01c1 027F	-	Reserved
0x01c1 0280	DFCNTRLD	EDMA3 TC0 Destination FIFO Set Count Reload Register
0x01c1 0284	DFSRCBREF	EDMA3 TC0 Destination FIFO Set Source Address B-Reference Register
0x01c1 0288	DFDSTBREF	EDMA3 TC0 Destination FIFO Set Destination Address B-Reference Register
0x01c1 028C - 0x01c1 02FF	-	Reserved
0x01c1 0300	DFOPT0	EDMA3 TC0 Destination FIFO Options Register 0
0x01c1 0304	DFSRC0	EDMA3 TC0 Destination FIFO Source Address Register 0



**Table 6-30. DM6446 EDMA Registers (continued)**

HEX ADDRESS	ACRONYM	REGISTER NAME
0x01c1 0308	DFCNT0	EDMA3 TC0 Destination FIFO Count Register 0
0x01c1 030C	DFDST0	EDMA3 TC0 Destination FIFO Destination Address Register 0
0x01c1 0310	DFBIDX0	EDMA3 TC0 Destination FIFO BIDX Register 0
0x01c1 0314	DFMPPRXY0	EDMA3 TC0 Destination FIFO Memory Protection Proxy Register 0
0x01c1 0318 - 0x01c1 033F	-	Reserved
0x01c1 0340	DFOPT1	EDMA3 TC0 Destination FIFO Options Register 1
0x01c1 0344	DFSRC1	EDMA3 TC0 Destination FIFO Source Address Register 1
0x01c1 0348	DFCNT1	EDMA3 TC0 Destination FIFO Count Register 1
0x01c1 034C	DFDST1	EDMA3 TC0 Destination FIFO Destination Address Register 1
0x01c1 0350	DFBIDX1	EDMA3 TC0 Destination FIFO BIDX Register 1
0x01c1 0354	DFMPPRXY1	EDMA3 TC0 Destination FIFO Memory Protection Proxy Register 1
0x01c1 0358 - 0x01c1 037F	-	Reserved
0x01c1 0380	DFOPT2	EDMA3 TC0 Destination FIFO Options Register 2
0x01c1 0384	DFSRC2	EDMA3 TC0 Destination FIFO Source Address Register 2
0x01c1 0388	DFCNT2	EDMA3 TC0 Destination FIFO Count Register 2
0x01c1 038C	DFDST2	EDMA3 TC0 Destination FIFO Destination Address Register 2
0x01c1 0390	DFBIDX2	EDMA3 TC0 Destination FIFO BIDX Register 2
0x01c1 0394	DFMPPRXY2	EDMA3 TC0 Destination FIFO Memory Protection Proxy Register 2
0x01c1 0398 - 0x01c1 03BF	-	Reserved
0x01c1 03C0	DFOPT3	EDMA3 TC0 Destination FIFO Options Register 3
0x01c1 03C4	DFSRC3	EDMA3 TC0 Destination FIFO Source Address Register 3
0x01c1 03C8	DFCNT3	EDMA3 TC0 Destination FIFO Count Register 3
0x01c1 03CC	DFDST3	EDMA3 TC0 Destination FIFO Destination Address Register 3
0x01c1 03D0	DFBIDX3	EDMA3 TC0 Destination FIFO BIDX Register 3
0x01c1 03D4	DFMPPRXY3	EDMA3 TC0 Destination FIFO Memory Protection Proxy Register 3
0x01c1 03D8 - 0x01c1 03FF	-	Reserved
<b>Transfer Controller 1 Registers</b>		
0x01c1 0400	-	Reserved
0x01c1 0404	TCCFG	EDMA3 TC1 Configuration Register
0x01c1 0408 - 0x01c1 04FF	-	Reserved
0x01c1 0500	TCSTAT	EDMA3 TC1 Channel Status Register
0x01c1 0504 - 0x01c1 0510	-	Reserved
0x01c1 0514 - 0x01c1 051F	-	Reserved
0x01c1 0520	ERRSTAT	EDMA3 TC1 Error Status Register
0x01c1 0524	ERREN	EDMA3 TC1 Error Enable Register
0x01c1 0528	ERRCLR	EDMA3 TC1 Error Clear Register
0x01c1 052C	ERRDET	EDMA3 TC1 Error Details Register
0x01c1 0530	ERRCMD	EDMA3 TC1 Error Interrupt Command Register
0x01c1 0534 - 0x01c1 053F	-	Reserved
0x01c1 0540	RDRATE	EDMA3 TC1 Read Rate Register
0x01c1 0544 - 0x01c1 05FF	-	Reserved
0x01c1 0600 - 0x01c1 063F	-	Reserved
0x01c1 0640	SAOPT	EDMA3 TC1 Source Active Options Register
0x01c1 0644	SASRC	EDMA3 TC1 Source Active Source Address Register
0x01c1 0648	SACNT	EDMA3 TC1 Source Active Count Register
0x01c1 064C	SADST	EDMA3 TC1 Source Active Destination Address Register
0x01c1 0650	SABIDX	EDMA3 TC1 Source Active Source B-Index Register

**Table 6-30. DM6446 EDMA Registers (continued)**

HEX ADDRESS	ACRONYM	REGISTER NAME
0x01c1 0654	SAMPPRXY	EDMA3 TC1 Source Active Memory Protection Proxy Register
0x01c1 0658	SACNTRLD	EDMA3 TC1 Source Active Count Reload Register
0x01c1 065C	SASRCBREF	EDMA3 TC1 Source Active Source Address B-Reference Register
0x01c1 0660	SADSTBREF	EDMA3 TC1 Source Active Destination Address B-Reference Register
0x01c1 0664 - 0x01c1 067F	-	Reserved
0x01c1 0680	DFCNTRLD	EDMA3 TC1 Destination FIFO Set Count Reload Register
0x01c1 0684	DFSRCBREF	EDMA3 TC1 Destination FIFO Set Source Address B-Reference Register
0x01c1 0688	DFDSTBREF	EDMA3 TC1 Destination FIFO Set Destination Address B-Reference Register
0x01c1 068C - 0x01c1 06FF	-	Reserved
0x01c1 0700	DFOPT0	EDMA3 TC1 Destination FIFO Options Register 0
0x01c1 0704	DFSRC0	EDMA3 TC1 Destination FIFO Source Address Register 0
0x01c1 0708	DFCNT0	EDMA3 TC1 Destination FIFO Count Register 0
0x01c1 070C	DFDST0	EDMA3 TC1 Destination FIFO Destination Address Register 0
0x01c1 0710	DFBIDX0	EDMA3 TC1 Destination FIFO BIDX Register 0
0x01c1 0714	DFMPPRXY0	EDMA3 TC1 Destination FIFO Memory Protection Proxy Register 0
0x01c1 0718 - 0x01c1 073F	-	Reserved
0x01c1 0740	DFOPT1	EDMA3 TC1 Destination FIFO Options Register 1
0x01c1 0744	DFSRC1	EDMA3 TC1 Destination FIFO Source Address Register 1
0x01c1 0748	DFCNT1	EDMA3 TC1 Destination FIFO Count Register 1
0x01c1 074C	DFDST1	EDMA3 TC1 Destination FIFO Destination Address Register 1
0x01c1 0750	DFBIDX1	EDMA3 TC1 Destination FIFO BIDX Register 1
0x01c1 0754	DFMPPRXY1	EDMA3 TC1 Destination FIFO Memory Protection Proxy Register 1
0x01c1 0758 - 0x01c1 077F	-	Reserved
0x01c1 0780	DFOPT2	EDMA3 TC1 Destination FIFO Options Register 2
0x01c1 0784	DFSRC2	EDMA3 TC1 Destination FIFO Source Address Register 2
0x01c1 0788	DFCNT2	EDMA3 TC1 Destination FIFO Count Register 2
0x01c1 078C	DFDST2	EDMA3 TC1 Destination FIFO Destination Address Register 2
0x01c1 0790	DFBIDX2	EDMA3 TC1 Destination FIFO BIDX Register 2
0x01c1 0794	DFMPPRXY2	EDMA3 TC1 Destination FIFO Memory Protection Proxy Register 2
0x01c1 0798 - 0x01c1 07BF	-	Reserved
0x01c1 07C0	DFOPT3	EDMA3 TC1 Destination FIFO Options Register 3
0x01c1 07C4	DFSRC3	EDMA3 TC1 Destination FIFO Source Address Register 3
0x01c1 07C8	DFCNT3	EDMA3 TC1 Destination FIFO Count Register 3
0x01c1 07CC	DFDST3	EDMA3 TC1 Destination FIFO Destination Address Register 3
0x01c1 07D0	DFBIDX3	EDMA3 TC1 Destination FIFO BIDX Register 3
0x01c1 07D4	DFMPPRXY3	EDMA3 TC1 Destination FIFO Memory Protection Proxy Register 3
0x01c1 07D8 - 0x01c1 07FF	-	Reserved

Table 6-31 shows an abbreviation of the set of registers which make up the parameter set for each of 128 EDMA events. Each of the parameter register sets consist of 8 32-bit word entries. Table 6-32 shows the parameter set entry registers with relative memory address locations within each of the parameter sets.

**Table 6-31. EDMA Parameter Set RAM**

HEX ADDRESS RANGE	DESCRIPTION
0x01c0 4000 - 0x01c0 401F	Parameters Set 0 (8 32-bit words)
0x01c0 4020 - 0x01c0 403F	Parameters Set 1 (8 32-bit words)
0x01c0 4040 - 0x01c0 405F	Parameters Set 2 (8 32-bit words)
0x01c0 4060 - 0x01c0 407F	Parameters Set 3 (8 32-bit words)
0x01c0 4080 - 0x01c0 409F	Parameters Set 4 (8 32-bit words)
0x01c0 40A0 - 0x01c0 40BF	Parameters Set 5 (8 32-bit words)
...	...
0x01c0 4FC0 - 0x01c0 4FDF	Parameters Set 126 (8 32-bit words)
0x01c0 4FE0 - 0x01c0 4FFF	Parameters Set 127 (8 32-bit words)

**Table 6-32. Parameter Set Entries**

HEX OFFSET ADDRESS WITHIN THE PARAMETER SET	ACRONYM	PARAMETER ENTRY
0x0000	OPT	Option
0x0004	SRC	Source Address
0x0008	A_B_CNT	A Count, B Count
0x000C	DST	Destination Address
0x0010	SRC_DST_BIDX	Source B Index, Destination B Index
0x0014	LINK_BCNTRLD	Link Address, B Count Reload
0x0018	SRC_DST_CIDX	Source C Index, Destination C Index
0x001C	CCNT	C Count

## 6.10 External Memory Interface (EMIF)

DM6446 supports several memory and external device interfaces, including:

- Asynchronous EMIF (EMIFA) for interfacing to NOR Flash, SRAM, etc.
- NAND Flash
- ATA/CF

### 6.10.1 Asynchronous EMIF (EMIFA)

The DM6446 Asynchronous EMIF (EMIFA) provides an 8-bit or 16-bit data bus, an address bus width up to 24-bits, and 4 dedicated chip selects, along with memory control signals. These signals are multiplexed between three peripherals:

- EMIFA and NAND interfaces
- ATA/CF
- Host Port Interface

#### 6.10.1.1 NAND (NAND, SmartMedia, xD)

The EMIFA interface provides both the asynchronous EMIF and NAND interfaces. Four chip selects are provided and each are individually configurable to provide either EMIFA or NAND support. The NAND features supported are as follows.

- NAND flash on up to 4 asynchronous chip selects.
- 8 and 16-bit data bus widths.
- Programmable cycle timings.
- Performs ECC calculation.
- NAND Mode also supports SmartMedia/SSFDC (Solid State Floppy Disk Controller) and xD memory cards
- ARM ROM supports booting of the DM6446 ARM processor from NAND flash located at CS2

The memory map for EMIFA and NAND registers is shown in [Table 6-33](#). For more details on the EMIFA and NAND interfaces, see the *TMS320DM644x DMSoC Peripherals Overview Reference Guide* (literature number [SPRUE19](#)) and the *TMS320DM644x DMSoC Asynchronous External Memory Interface (EMIF) User's Guide* (literature number [SPRUE20](#)).

**Table 6-33. EMIFA/NAND Registers**

HEX ADDRESS RANGE	ACRONYM	REGISTER NAME
0x01E0 0000 - 0x01E0 0003		Reserved
0x01E0 0004	AWCCR	Asynchronous Wait Cycle Configuration Register
0x01E0 0008 - 0x01E0 000F		Reserved
0x01E0 0010	A1CR	Asynchronous 1 Configuration Register (CS2 Space)
0x01E0 0014	A2CR	Asynchronous 2 Configuration Register (CS3 Space)
0x01E0 0018	A3CR	Asynchronous 3 Configuration Register (CS4 Space)
0x01E0 001C	A4CR	Asynchronous 4 Configuration Register (CS5 Space)
0x01E0 0020 - 0x01E0 003F	-	Reserved
0x01E0 0040	EIRR	EMIF Interrupt Raw Register
0x01E0 0044	EIMR	EMIF Interrupt Mask Register
0x01E0 0048	EIMSR	EMIF Interrupt Mask Set Register
0x01E0 004C	EIMCR	EMIF Interrupt Mask Clear Register
0x01E0 0050 - 0x01E0 005F	-	Reserved
0x01E0 0060	NANDFCR	NAND Flash Control Register
0x01E0 0064	NANDFSR	NAND Flash Status Register
0x01E0 0070	NANDF1ECC	NAND Flash 1 ECC Register (CS2 Space)
0x01E0 0074	NANDF2ECC	NAND Flash 2 ECC Register (CS3 Space)
0x01E0 0078	NANDF3ECC	NAND Flash 3 ECC Register (CS4 Space)
0x01E0 007C	NANDF4ECC	NAND Flash 4 ECC Register (CS5 Space)
0x01E0 0080 - 0x01E0 0FFF	-	Reserved

### 6.10.1.2 EMIFA Electrical Data/Timing

**Table 6-34. Timing Requirements for Asynchronous Memory Cycles for EMIFA Module<sup>(1)</sup>**  
(see [Figure 6-21](#) and [Figure 6-22](#))

NO.			MIN	MAX	UNIT
<b>READS and WRITES</b>					
2	$t_{w(EM\_WAIT)}$	Pulse duration, EM_WAIT assertion and deassertion	2E		ns
<b>READS</b>					
12	$t_{su(EMDV-EMOE\overline{H})}$	Setup time, EM_D[15:0] valid before $\overline{EM\_OE}$ high	10.5		ns
13	$t_{h(EMOE\overline{H}-EMDIV)}$	Hold time, EM_D[15:0] valid after $\overline{EM\_OE}$ high	0		ns
14	$t_{su(EMWAIT-EMOE\overline{H})}$	Setup time, EM_WAIT asserted before $\overline{EM\_OE}$ high <sup>(2)</sup>	4E + 10.4		ns
<b>WRITES</b>					
28	$t_{su(EMWAIT-EMWE\overline{H})}$	Setup time, EM_WAIT asserted before $\overline{EM\_WE}$ high <sup>(2)</sup>	4E + 10.4		ns

- (1) E = SYSCLK5 period in ns for EMIFA. For example, when running the DSP CPU at 594 MHz, use E = 10.1 ns.
- (2) Setup before end of STROBE phase (if no extended wait states are inserted) by which EM\_WAIT must be asserted to add extended wait states. [Figure 6-23](#) and [Figure 6-24](#) describe EMIF transactions that include extended wait states inserted during the STROBE phase. However, cycles inserted as part of this extended wait period should not be counted; the 4E requirement is to the start of where the HOLD phase would begin if there were no extended wait cycles.

**Table 6-35. Switching Characteristics Over Recommended Operating Conditions for Asynchronous Memory Cycles for EMIFA Module<sup>(1)(2)</sup> (see Figure 6-21 and Figure 6-22)**

NO.	PARAMETER		MIN	MAX	UNIT
<b>READS and WRITES</b>					
1	$t_d(\text{TURNAROUND})$	Turn around time	$(TA + 1) * E - 2$	$(TA + 1) * E + 2$	ns
<b>READS</b>					
3	$t_c(\text{EMRCYCLE})$	EMIF read cycle time (EW = 0)	$(RS + RST + RH + TA + 4) * E - 0.5$	$(RS + RST + RH + TA + 4) * E + 0.5$	ns
		EMIF read cycle time (EW = 1)	$(RS + RST + RH + TA + 4) * E - 0.5$	$4184 * E + 0.5$	ns
4	$t_{su}(\text{EMCSL-EMOEL})$	Output setup time, $\overline{EM\_CS}[5:2]$ low to $\overline{EM\_OE}$ low (SS = 0)	$(RS + 1) * E - 1$	$(RS + 1) * E + 1.4$	ns
		Output setup time, $\overline{EM\_CS}[5:2]$ low to $\overline{EM\_OE}$ low (SS = 1)	-1		ns
5	$t_h(\text{EMOEH-EMCSH})$	Output hold time, $\overline{EM\_OE}$ high to $\overline{EM\_CS}[5:2]$ high (SS = 0)	$(RH + 1) * E - 2.1$	$(RH + 1) * E + 1.4$	ns
		Output hold time, $\overline{EM\_OE}$ high to $\overline{EM\_CS}[5:2]$ high (SS = 1)	-2.2		ns
6	$t_{su}(\text{EMBAV-EMOEL})$	Output setup time, $\overline{EM\_BA}[1:0]$ valid to $\overline{EM\_OE}$ low	$(RS + 1) * E - 1.8$	$(RS + 1) * E + 1.3$	ns
7	$t_h(\text{EMOEH-EMBAIV})$	Output hold time, $\overline{EM\_OE}$ high to $\overline{EM\_BA}[1:0]$ invalid	$(RH + 1) * E - 2.3$	$(RH + 1) * E + 1.1$	ns
8	$t_{su}(\text{EMAV-EMOEL})$	Output setup time, $\overline{EM\_A}[21:0]$ valid to $\overline{EM\_OE}$ low	$(RS + 1) * E - 1.9$	$(RS + 1) * E + 1.5$	ns
9	$t_h(\text{EMOEH-EMAIV})$	Output hold time, $\overline{EM\_OE}$ high to $\overline{EM\_A}[21:0]$ invalid	$(RH + 1) * E - 2.6$	$(RH + 1) * E + 1.2$	ns
10	$t_w(\text{EMOEL})$	$\overline{EM\_OE}$ active low width (EW = 0)	$(RST + 1) * E - 2$	$(RST + 1) * E + 2$	ns
		$\overline{EM\_OE}$ active low width (EW = 1)	$(RST + 1) * E - 2$	$(RST + 4097) * E + 2$	ns
11	$t_d(\text{EMWAITH-EMOEH})$	Delay time from EM_WAIT deasserted to $\overline{EM\_OE}$ high		$4E + 10.4$	ns
<b>WRITES</b>					
15	$t_c(\text{EMWCYCLE})$	EMIF write cycle time (EW = 0)	$(WS + WST + WH + TA + 4) * E - 0.5$	$(WS + WST + WH + TA + 4) * E + 0.5$	ns
		EMIF write cycle time (EW = 1)	$(WS + WST + WH + TA + 4) * E - 0.5$	$4184 * E + 0.5$	ns
16	$t_{su}(\text{EMCSL-EMWEL})$	Output setup time, $\overline{EM\_CS}[5:2]$ low to $\overline{EM\_WE}$ low (SS = 0)	$(WS + 1) * E - 0.9$	$(WS + 1) * E + 1.4$	ns
		Output setup time, $\overline{EM\_CS}[5:2]$ low to $\overline{EM\_WE}$ low (SS = 1)	-1		ns
17	$t_h(\text{EMWEH-EMCSH})$	Output hold time, $\overline{EM\_WE}$ high to $\overline{EM\_CS}[5:2]$ high (SS = 0)	$(WH + 1) * E - 2.1$	$(WH + 1) * E + 1.1$	ns
		Output hold time, $\overline{EM\_WE}$ high to $\overline{EM\_CS}[5:2]$ high (SS = 1)	-2.1		ns
18	$t_{su}(\text{EMRNW-EMWEL})$	Output setup time, $EM\_R\overline{W}$ valid to $\overline{EM\_WE}$ low	$(WS + 1) * E - 0.7$	$(WS + 1) * E + 0.9$	ns
19	$t_h(\text{EMWEH-EMRNW})$	Output hold time, $\overline{EM\_WE}$ high to $EM\_R\overline{W}$ invalid	$(WH + 1) * E - 0.9$	$(WH + 1) * E + 0.9$	ns
20	$t_{su}(\text{EMBAV-EMWEL})$	Output setup time, $\overline{EM\_BA}[1:0]$ valid to $\overline{EM\_WE}$ low	$(WS + 1) * E - 1.7$	$(WS + 1) * E + 1.5$	ns
21	$t_h(\text{EMWEH-EMBAIV})$	Output hold time, $\overline{EM\_WE}$ high to $\overline{EM\_BA}[1:0]$ invalid	$(WH + 1) * E - 2.3$	$(WH + 1) * E + 0.9$	ns
22	$t_{su}(\text{EMAV-EMWEL})$	Output setup time, $\overline{EM\_A}[21:0]$ valid to $\overline{EM\_WE}$ low	$(WS + 1) * E - 1.8$	$(WS + 1) * E + 1.7$	ns
23	$t_h(\text{EMWEH-EMAIV})$	Output hold time, $\overline{EM\_WE}$ high to $\overline{EM\_A}[21:0]$ invalid	$(WH + 1) * E - 2.6$	$(WH + 1) * E + 1$	ns
24	$t_w(\text{EMWEL})$	$\overline{EM\_WE}$ active low width (EW = 0)	$(WST + 1) * E - 2$	$(WST + 1) * E + 2$	ns
		$\overline{EM\_WE}$ active low width (EW = 1)	$(WST + 1) * E - 2$	$(WST + 4097) * E + 2$	
25	$t_d(\text{EMWAITH-EMWEH})$	Delay time from EM_WAIT deasserted to $\overline{EM\_WE}$ high		$4E + 10.4$	ns
26	$t_{su}(\text{EMDV-EMWEL})$	Output setup time, $\overline{EM\_D}[15:0]$ valid to $\overline{EM\_WE}$ low	$(WS + 1) * E - 2.2$	$(WS + 1) * E + 1.4$	ns
27	$t_h(\text{EMWEH-EMDIV})$	Output hold time, $\overline{EM\_WE}$ high to $\overline{EM\_D}[15:0]$ invalid	$(WH + 1) * E - 2.2$	$(WH + 1) * E + 1.4$	ns

(1) RS = Read setup, RST = Read STrobe, RH = Read Hold, WS = Write Setup, WST = Write STrobe, WH = Write Hold, TA = Turn Around, EW = Extend Wait mode, SS = Select Strobe mode. These parameters are programmed via the Asynchronous Bank and Asynchronous Wait Cycle Configuration Registers and support the following range of values: TA[3:0], RS[15:0], RST[63:0], RH[7:0], WS[15:0], WST[63:0], WH[7:0], and EW[255:0]. For more information, see the *TMS320DM644x DMSoC Asynchronous External Memory Interface (EMIF) User's Guide* (literature number [SPRUE20](#)).

(2) E = SYSCLK5 period in ns for EMIFA. For example, when running the DSP CPU at 594 MHz, use E = 10.1 ns.

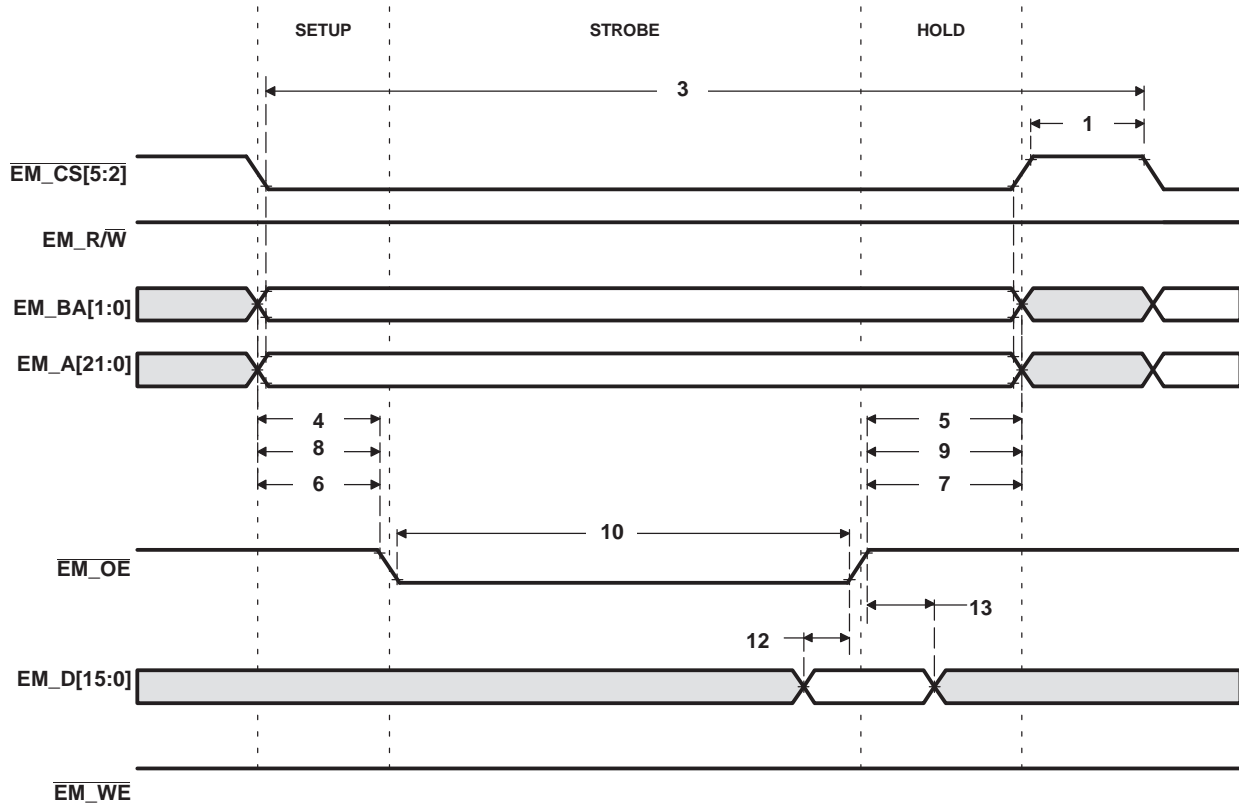

Figure 6-21. Asynchronous Memory Read Timing for EMIF



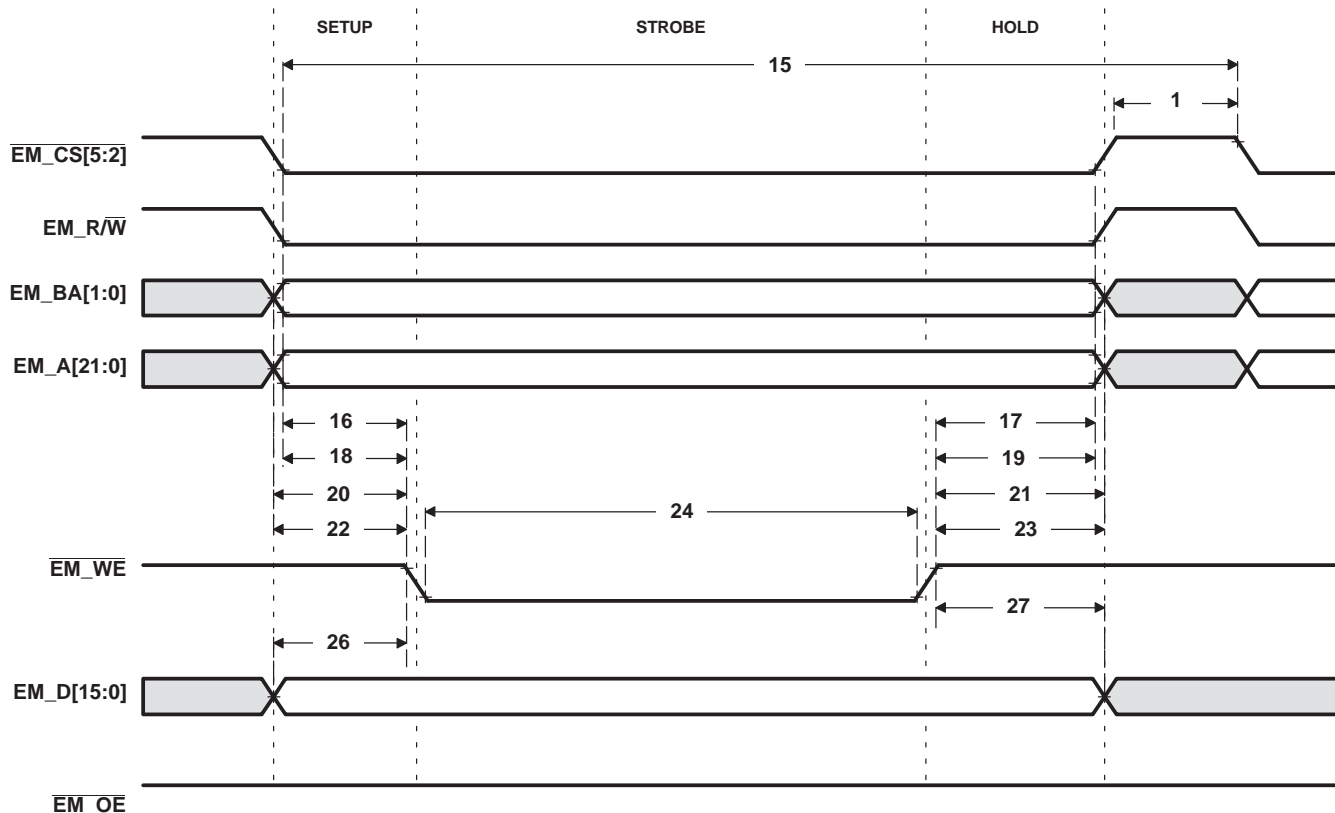

Figure 6-22. Asynchronous Memory Write Timing for EMIF

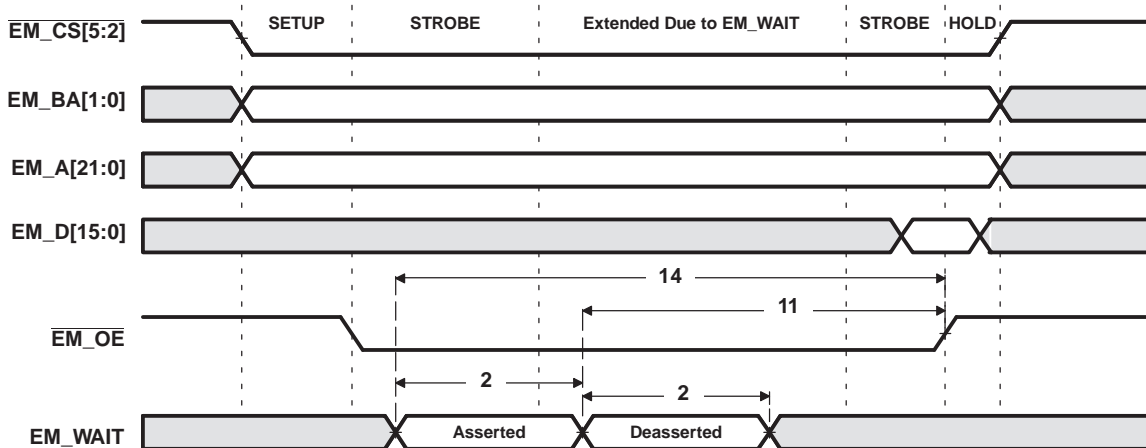

Figure 6-23.  $\overline{EM\_WAIT}$  Read Timing Requirements

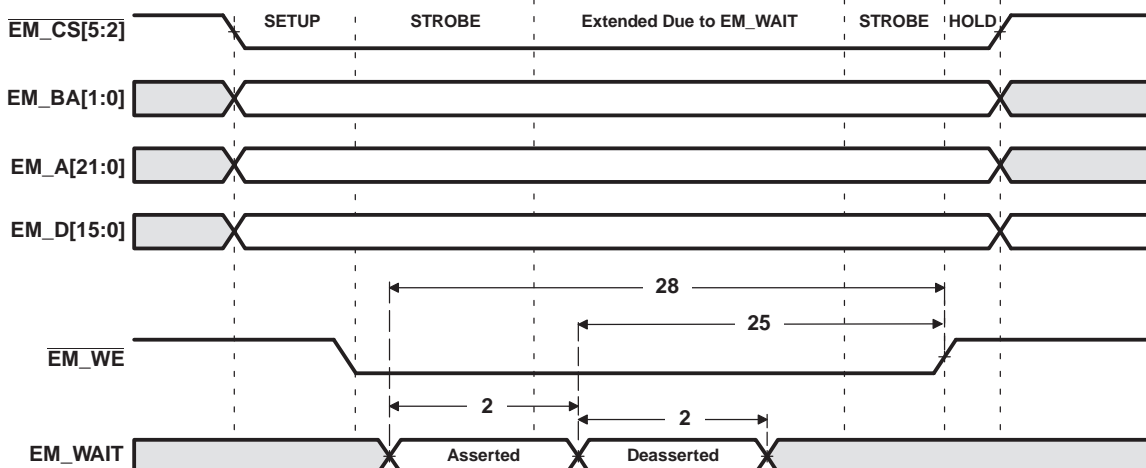

Figure 6-24. EM\_WAIT Write Timing Requirements

### 6.10.2 DDR2 Memory Controller

The DDR2 Memory Controller is a dedicated interface to DDR2 SDRAM. It supports JESD79D-2A standard compliant DDR2 SDRAM Devices and can interface to either 16-bit or 32-bit DDR2 SDRAM devices. For details on the DDR2 Memory Controller, see [Section 2.8.3, Document Support](#) for the link to the *TMS320DM644x DMSoC Peripherals Overview Reference Guide* (literature number SPRUE19) for the *TMS320DM644x DMSoC DDR2 Memory Controller User's Guide* (literature number SPRUE22).

DDR2 SDRAM plays a key role in a DaVinci-based system. Such a system is expected to require a significant amount of high-speed external memory for:

- Buffering of input image data from sensors or video sources
- Intermediate buffering for processing/resizing of image data in the VPFE
- Numerous OSD display buffers
- Intermediate buffering for large raw Bayer data image files while performing image processing functions
- Buffering for intermediate data while performing video encode and decode functions
- Storage of executable code for both the ARM and DSP

A memory map of the DDR2 Memory Controller registers is shown in [Table 6-36](#).

Table 6-36. DDR2 Memory Controller Registers

HEX ADDRESS RANGE	ACRONYM	REGISTER NAME
0x01C4 004C	DDRVTPER	DDR2 VTP Enable Register
0x01C4 2030	DDRVTPR	DDR2 VTP Register
0x2000 0000 - 0x2000 0003	-	Reserved
0x2000 0004	SDRSTAT	SDRAM Status Register
0x2000 0008	SDBCR	SDRAM Bank Configuration Register
0x2000 000C	SDRCR	SDRAM Refresh Control Register
0x2000 0010	SDTIMR	SDRAM Timing Register
0x2000 0014	SDTIMR2	SDRAM Timing Register 2
0x2000 0020	PBBPR	Peripheral Bus Burst Priority Register
0x2000 0024 - 0x2000 00BF	-	Reserved
0x2000 00C0	IRR	Interrupt Raw Register
0x2000 00C4	IMR	Interrupt Masked Register
0x2000 00C8	IMSR	Interrupt Mask Set Register

**Table 6-36. DDR2 Memory Controller Registers (continued)**

HEX ADDRESS RANGE	ACRONYM	REGISTER NAME
0x2000 00CC	IMCR	Interrupt Mask Clear Register
0x2000 00D0 - 0x2000 00E3	-	Reserved
0x2000 00E4	DDRPHYCR	DDR PHY Control Register
0x2000 00E8 - 0x2000 00EF	-	Reserved
0x2000 00F0	VTPIOCR	VTP IO Control Register
0x2000 00F4 - 0x2000 7FFF	-	Reserved

### 6.10.2.1 DDR2 Memory Controller Electrical Data/Timing

The *Implementing DDR2 PCB Layout on the DM644x DMSoC* application report (literature number SPRAAC5) specifies a complete DDR2 interface solution for the DM6446 as well as a list of compatible DDR2 devices. TI has performed the simulation and system characterization to ensure all DDR2 interface timings in this solution are met.

TI only supports board designs that follow the guidelines outlined in the *Implementing DDR2 PCB Layout on the DM644x DMSoC* application report (literature number [SPRAAC5](#)).

**Table 6-37. Switching Characteristics Over Recommended Operating Conditions for DDR2 Memory Controller<sup>(1)(2)</sup>(see [Figure 6-25](#))**

NO.	PARAMETER	MIN	MAX	UNIT
1	$t_{c(DDR\_CLK0)}$ Cycle time, DDR_CLK0	6	8	ns

(1) DDR\_CLK0 cycle time = 2 x PLL2 - SYSCLK2 cycle time.

(2) The PLL2 Controller **must** be programmed such that the resulting DDR\_CLK0 clock frequency is within the specified range.

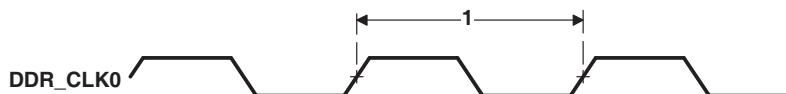

**Figure 6-25. DDR2 Memory Controller Clock Timing**

## 6.11 ATA/CF

The ATA/CF peripheral supports the following features:

- PIO, multiword DMA, and Ultra ATA 33/66
- Up to mode 4 timings on PIO mode
- Up to mode 2 timings on multiword DMA
- Up to mode 4 timings on Ultra ATA
- Programmable timing parameters
- Supports TrueIDE mode for Compact Flash

In addition, the Host IDE Controller supports multiword DMA transfers between external IDE/ATAPI devices and a system memory bus interface.

### 6.11.1 ATA/CF Peripheral Register Description(s)

The ATA registers are shown in [Table 6-38](#).

**Table 6-38. ATA Register Memory Map**

HEX ADDRESS RANGE	ACRONYM	REGISTER NAME
<b>ATA Bus Master Interface DMA Engine Registers</b>		
0x01C6 6000	BMICP	Primary IDE Channel DMA Control Register
0x01C6 6002	BMISP	Primary IDE Channel DMA Status Register
0x01C6 6004	BMIDTP	Primary IDE Channel DMA Descriptor Table Pointer Register
0x01C6 6008	-	Reserved
0x01C6 600A	-	
0x01C6 600C	-	
<b>ATA Configuration Registers</b>		
0x01C6 6040	IDETIMP	Primary IDE Channel Timing Register
0x01C6 6042	-	Reserved
0x01C6 6044	-	
0x01C6 6045	-	
0x01C6 6047	IDESTAT	IDE Controller Status Register
0x01C6 6048	UDMACTL	Ultra-DMA Control Register
0x01C6 604A	-	Reserved
0x01C6 6050	MISCCTL	Miscellaneous Control Register
0x01C6 6054	REGSTB	Task File Register Strobe Timing Register
0x01C6 6058	REGRCVR	Task File Register Recovery Timing Register
0x01C6 605C	DATSTB	Data Register Access PIO Strobe Timing Register
0x01C6 6060	DATRCVR	Data Register Access PIO Recovery Timing Register
0x01C6 6064	DMASTB	Multiword DMA Strobe Timing Register
0x01C6 6068	DMARCVR	Multiword DMA Recovery Timing Register
0x01C6 606C	UDMASTB	Ultra-DMA Strobe Timing Register
0x01C6 6070	UDMATRP	Ultra-DMA Ready-to-Pause Timing Register
0x01C6 6074	UDMATENV	Ultra-DMA Timing Envelope Register
0x01C6 6078	IORDYTMP	Primary IO Ready Timer Configuration Register
0x01C6 607C - 0x01C6 67FF	-	Reserved

## 6.11.2 ATA/CF Electrical Data/Timing

All ATA/CF AC timing data described in [Section 6.11.2.1](#) – [Section 6.11.2.3](#) is provided at the DM6446 device pins. For more details, see [Section 6.1](#), *Parameter Information*.

The AC timing specifications described in [Section 6.11.2.1](#) – [Section 6.11.2.3](#) assume correct configuration of the ATA/CF memory-mapped control registers for the selected ATA/CF frequency of operation.

### 6.11.2.1 ATA/CF PIO Data Transfer AC Timing

**Table 6-39. Timings for ATA/CF Module — PIO Data Transfer<sup>(1)(2)</sup> (see [Figure 6-26](#))**

NO.		MODE	MIN	MAX	UNIT
1	$t_0$	Cycle time	0-4 <sup>(3)</sup>	(DATSTB + DATRCVR + 2)P - 0.5	ns
2	$t_1$	Address valid to $\overline{\text{DIOW}}/\overline{\text{DIOR}}$ setup	0-4 <sup>(3)</sup>	12P - 1.6	ns
3	$t_2$	$\overline{\text{DIOW}}/\overline{\text{DIOR}}$ pulse duration low	0-4 <sup>(3)</sup>	(DATSTB + 1)P - 1	ns ns
4	$t_{2i}$	$\overline{\text{DIOW}}/\overline{\text{DIOR}}$ recovery time, pulse duration high	0-2 3-4 <sup>(3)</sup>	– (DATRCVR + 1)P - 1	
5	$t_3$	$\overline{\text{DIOW}}$ data setup time, DD[15:0] valid before $\overline{\text{DIOW}}$ rising edge	0-4 <sup>(3)</sup>	(DATSTB + 1)P	ns
6	$t_4$	$\overline{\text{DIOW}}$ data hold time, DD[15:0] valid after $\overline{\text{DIOW}}$ rising edge	0-4 <sup>(3)</sup>	(HWNHLD + 1)P + 1	ns
7	$t_5$	$\overline{\text{DIOR}}$ data setup time, DD[15:0] valid before $\overline{\text{DIOR}}$ rising edge	0	50	ns
			1	35	ns
			2-4 <sup>(3)</sup>	20	ns
8	$t_6$	$\overline{\text{DIOR}}$ data hold time, DD[15:0] valid after $\overline{\text{DIOR}}$ rising edge	0-4 <sup>(3)</sup>	5	ns
9	$t_{6Z}$	Output data 3-state, DD[15:0] 3-state after $\overline{\text{DIOR}}$ rising edge	0-4 <sup>(3)</sup>	30	ns
10	$t_9$	$\overline{\text{DIOW}}/\overline{\text{DIOR}}$ to address valid hold	0-4 <sup>(3)</sup>	(HWNHLD + 1)P - 2.1	ns
11	$t_{RD}$	Read data setup time, DD[15:0] valid before IORDY active	0-4 <sup>(3)</sup>	0	ns
12	$t_A$	IORDY setup	0-4 <sup>(3)(4)</sup>	35	ns
13	$t_B$	IORDY pulse width	0-4 <sup>(3)</sup>	1250	ns
14	$t_C$	IORDY assertion to release	0-4 <sup>(3)</sup>	5	ns

(1) P = SYSCLK5 period, in ns, for ATA. For example, when running the DSP CPU at 594 MHz, use P = 10.1 ns.

(2) DATSTB equals the value programmed in the DATSTBxP bit field in the DATSTB register. DATRCVR equals the value programmed in the DATRCVRxP bit field in the DATRCVR register. HWNHLD equals the value programmed in the HWNHLDxP bit field in the MISCCTL register. For more detailed information, see the *TMS320DM644x DMSoC ATA Controller User's Guide* (literature number [SPRUE21](#)).

(3) The sustained throughput for PIO modes 3 and 4 is limited to the throughput equivalent of PIO mode 2. For more detailed information, see the *TMS320DM644x DMSoC ATA Controller User's Guide* (literature number [SPRUE21](#)).

(4) The  $t_A$  parameter must be met only when the IORDY timer is enabled to allow a device to insert wait states during a transaction. In order to meet the  $t_A$  parameter, a minimum frequency for SYSCLK5 is specified for each PIO as follows:

- PIO mode 0, MIN frequency = 15 MHz
- PIO mode 1, MIN frequency = 22 MHz
- PIO mode 2, MIN frequency = 31 MHz
- PIO mode 3, MIN frequency = 45 MHz
- PIO mode 4, MIN frequency = 57 MHz

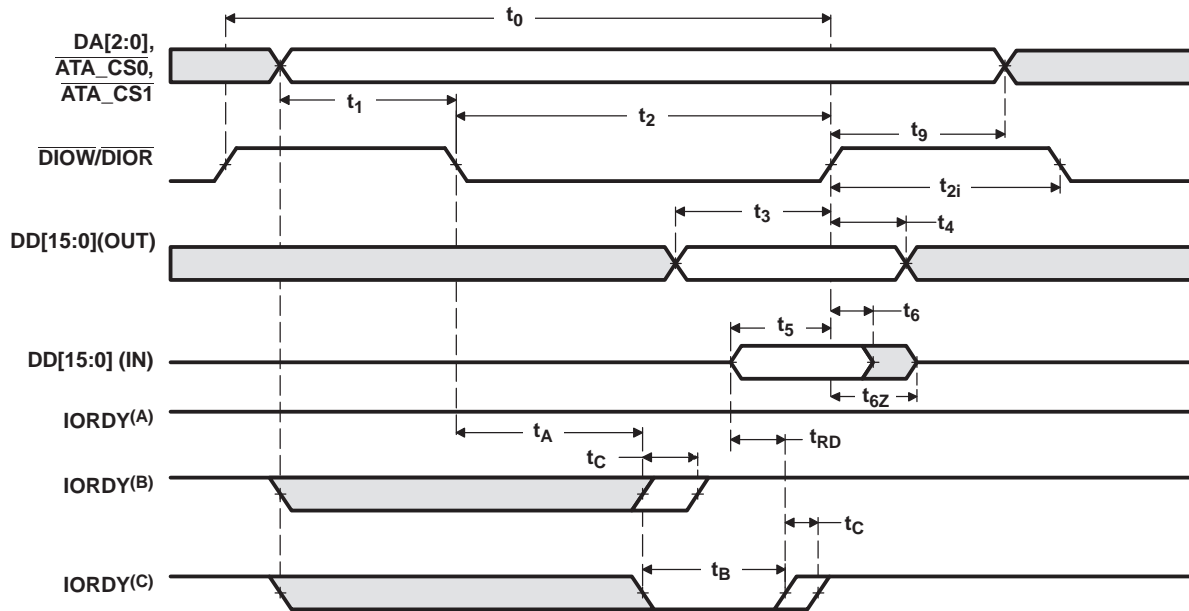

- A. IORDY is not negated for transfer (no wait generated)
- B. IORDY is negative but is re-asserted before  $t_A$  (no wait is generated)
- C. IORDY is negative before  $t_A$  and remains asserted until  $t_B$ ; data is driven valid at  $t_{RD}$  (wait is generated)

Figure 6-26. ATA/CF PIO Data Transfer Timing

### 6.11.2.2 ATA/CF Multiword DMA Timing

**Table 6-40. Timings for ATA/CF Module — Multiword DMA AC Timing<sup>(1)(2)</sup> (see [Figure 6-27](#))**

NO.		MODE	MIN	MAX	UNIT
1	$t_0$	Cycle time	0-2	$(DMASTB + DMARCVR + 2)P - 0.5$	ns
2	$t_D$	$\overline{DIOW}/\overline{DIOR}$ active low pulse duration	0-2	$(DMASTB + 1)P - 1$	ns
3	$t_E$	$\overline{DIOR}$ data access, $\overline{DIOR}$ falling edge to DD[15:0] valid	0	150	ns
			1	60	ns
			2	50	ns
4	$t_F$	$\overline{DIOR}$ data hold time, DD[15:0] valid after $\overline{DIOR}$ rising edge	0-2	5	ns
5	$t_G$	$\overline{DIOW}/\overline{DIOR}$ data setup time, DD[15:0] ( <b>OUT</b> ) valid before $\overline{DIOW}/\overline{DIOR}$ rising edge	0-2	$(DMASTB)P$	ns
			0	100	ns
			1	30	ns
		$\overline{DIOW}/\overline{DIOR}$ data setup time, DD[15:0] ( <b>IN</b> ) valid before $\overline{DIOW}/\overline{DIOR}$ rising edge	2	20	ns
6	$t_H$	$\overline{DIOW}$ data hold time, DD[15:0] valid after $\overline{DIOW}$ rising edge	0-2	$(HWNHLD + 1)P + 1$	ns
7	$t_I$	$\overline{DMACK}$ to $\overline{DIOW}/\overline{DIOR}$ setup	0-2	$(DMARCVR + 1)P - 1.7$	ns
8	$t_J$	$\overline{DIOW}/\overline{DIOR}$ to $\overline{DMACK}$ hold	0-2	$5P - 5.9$	ns
9	$t_{KR}$	$\overline{DIOR}$ negated pulse width	0-2	$(DMARCVR + 1)P - 1$	ns
10	$t_{KW}$	$\overline{DIOW}$ negated pulse width	0-2	$(DMARCVR + 1)P - 1$	ns
11	$t_{LR}$	$\overline{DIOR}$ to DMARQ delay	0	120	ns
			1	45	ns
			2	35	ns
12	$t_{LW}$	$\overline{DIOW}$ to DMARQ delay	0-1	40	ns
			2	35	ns
13	$t_M$	$\overline{ATA\_CSx}$ valid to $\overline{DIOW}/\overline{DIOR}$ setup	0-2	$(DATRCVR)P - 1.7$	ns
14	$t_N$	$\overline{ATA\_CSx}$ valid after $\overline{DIOW}/\overline{DIOR}$ rising edge hold	0-2	$5P - 1.7$	ns
15	$t_Z$	$\overline{DMACK}$ to read data (DD[15:0]) released	0	20	ns
			1-2	25	ns

(1) P = SYSCLK5 period, in ns, for ATA. For example, when running the DSP CPU at 594 MHz, use P = 10.1 ns.

(2) DMASTB equals the value programmed in the DMASTBxP bit field in the DMASTB register. DMARCVR equals the value programmed in the DMARCVRxP bit field in the DMARCVR register. HWNHLD equals the value programmed in the HWNHLDxP bit field in the MISCCTL register. For more detailed information, see the *TMS320DM644x DMSoC ATA Controller User's Guide* (literature number [SPRUE21](#)).

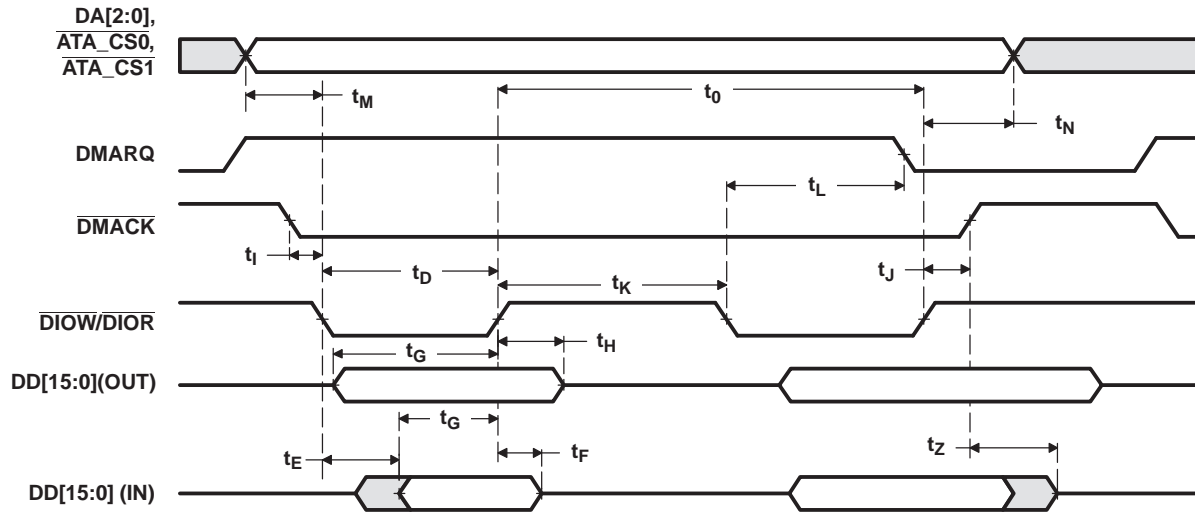

Figure 6-27. ATA/CF Multiword DMA Timing



### 6.11.2.3 ATA/CF Ultra DMA Timing

**Table 6-41. Timings for ATA/CF Module — Ultra DMA AC Timing<sup>(1)(2)</sup>**  
 (see [Figure 6-28](#) through [Figure 6-37](#))

NO.		MODE	MIN	MAX	UNIT
28	$f_{(\text{SYSCLK5})}$ Operating frequency, SYSCLK5	0-4	25		MHz
1	$t_{2\text{CYCTYP}}$ Typical sustained average two cycle time	0	240		ns
		1	160		ns
		2	120		ns
		3	90		ns
		4	60		ns
2	$t_{\text{CYC}}$ Cycle time, Strobe edge to Strobe edge	0-4	(UDMASTB + 1)P		ns
3	$t_{2\text{CYC}}$ Two cycle time, rising to rising edge or falling to falling edge	0-4	2(UDMASTB + 1)P		ns
4	$t_{\text{DS}}$ Data setup, data valid before STROBE edge	0	15		ns
		1	10		ns
		2-3	7		ns
		4	5		ns
5	$t_{\text{DH}}$ Data hold, data valid after STROBE edge	0-4	5		ns
6	$t_{\text{DVS}}$	Data valid <b>INPUT</b> setup time, data valid before STROBE	0	70	ns
			1	48	ns
			2	31	ns
			3	20	ns
		4	6.7	ns	
7	$t_{\text{DVH}}$	Data valid <b>INPUT</b> hold time, data valid after STROBE	0-4	6.2	ns
		Data valid <b>OUTPUT</b> hold time, data valid after STROBE	0-4	1P - 2	ns
10	$t_{\text{CVS}}$ CRC word valid setup time at host, CRC valid before $\overline{\text{DMACK}}$ negation	0-4	(UDMASTB)P		ns
11	$t_{\text{CVH}}$ CRC word valid hold time at sender, CRC valid after $\overline{\text{DMACK}}$ negation	0-4	2P		ns
12	$t_{\text{ZFS}}$ Time from STROBE output released-to-driving until the first transition of critical timing	0-4	0		ns
13	$t_{\text{DZFS}}$ Time from data output released-to-driving until the first transition of critical timing	0	70		ns
		1	48		ns
		2	31		ns
		3	20		ns
		4	6.7		ns
14	$t_{\text{FS}}$ First STROBE time	0		230	ns
		1		200	ns
		2		170	ns
		3		130	ns
		4		120	ns
15	$t_{\text{LI}}$ Limited interlock time	0-4	0	150	ns
16	$t_{\text{MLI}}$ Interlock time with minimum	0-4	20		ns

(1) P = SYSCLK5 period, in ns, for ATA. For example, when running the DSP CPU at 594 MHz, use P = 10.1 ns.

(2) UDMASTB equals the value programmed in the UDMSTBxP bit field in the UDMASTB register. UDMATRP equals the value programmed in the UDMTRPxP bit field in the UDMATRP register. TENV equals the value programmed in the UDMATNVxP bit field in the UDMATENV register. For more detailed information, see the *TMS320DM644x DMSoC ATA Controller User's Guide* (literature number [SPRUE21](#)).

**Table 6-41. Timings for ATA/CF Module — Ultra DMA AC Timing**  
(see Figure 6-28 through Figure 6-37) (continued)

NO.			MODE	MIN	MAX	UNIT
17	$t_{UI}$	Unlimited interlock time	0-4	0		ns
18	$t_{AZ}$	Maximum time allowed for output drivers to release	0-4		10	ns
19	$t_{ZAH}$	Minimum delay time required for output	0-4	20		ns
20	$t_{ZAD}$	Minimum delay time for driver to assert or negate (from released)	0-4	0		ns
21	$t_{ENV}$	Envelope time, $\overline{DMACK}$ to STOP and $\overline{DMACK}$ to $\overline{HDMARDY}$ during in-burst initiation and from $\overline{DMACK}$ to STOP during data out burst initiation	0-4	$(TENV + 1)P - 0.5$	$(TENV + 1)P + 1.4$	ns
22	$t_{RFS}$	Ready-to-final-STROBE time	0		75	ns
			1		70	ns
			2-4		60	ns
23	$t_{RP}$	Ready to pause time, ( $\overline{HDMARDY}$ ( $\overline{DIOR}$ ) to STOP ( $\overline{DIOW}$ ))	0-4	$(UDMATRP + 1)P - 0.8$		ns
			0	160		ns
		Ready to pause time, ( $\overline{DDMARDY}$ ( $\overline{IORDY}$ ) to $\overline{DMARQ}$ )	1	125		ns
			2-4	100		ns
24	$t_{IORDYZ}$	Maximum time before releasing IORDY	0-4		20	ns
25	$t_{ZIORDY}$	Minimum time before driving IORDY	0-4	0		ns
26	$t_{ACK}$	Setup and hold time for $\overline{DMACK}$ (before assertion or negation)	0-4	20		ns
27	$t_{SS}$	STROBE edge to negation of $\overline{DMARQ}$ or assertion of STOP (when sender terminates a burst)	0-4	50		ns

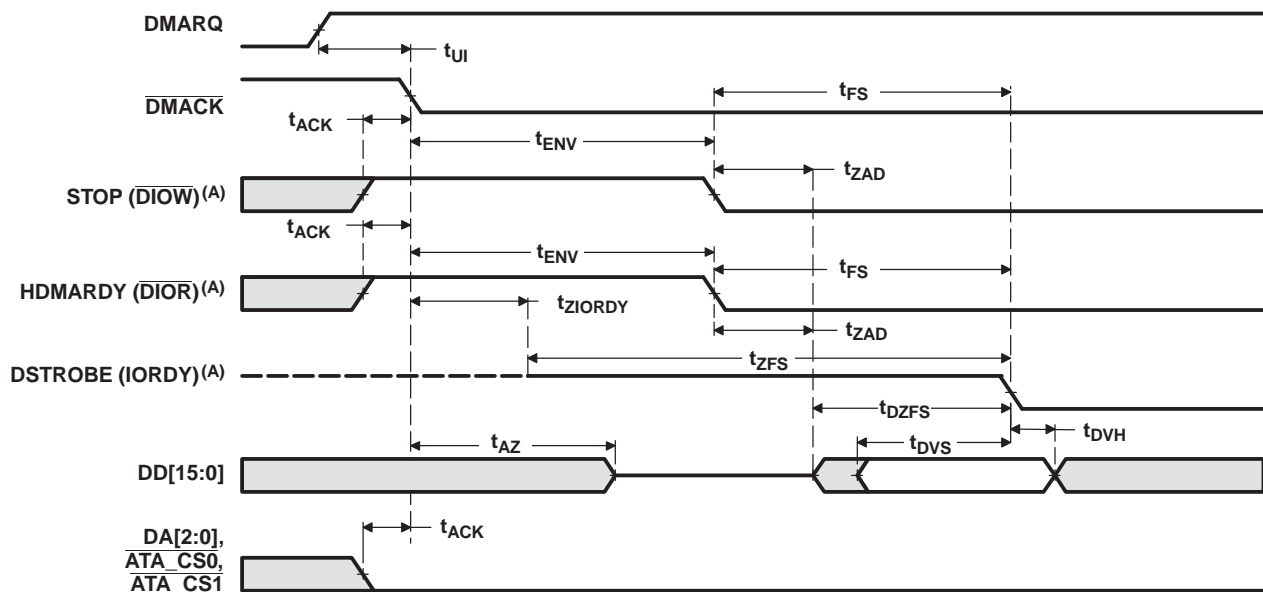

A. The definitions for the  $\overline{DIOW}$ :STOP,  $\overline{DIOR}$ : $\overline{HDMARDY}$ , and IORDY:DSTROBE signal lines are not in effect until  $\overline{DMARQ}$  and  $\overline{DMACK}$  are asserted.

**Figure 6-28. ATA/CF Initiating an Ultra DMA Data-In Burst Timing**

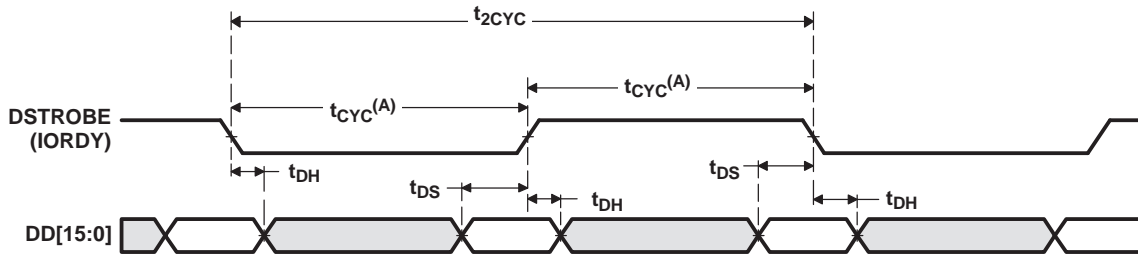

- A. While DSTROBE (IORDY) timing is  $t_{CYC}$  at the device, it may be different at the host due to propagation delay differences on the cable.

Figure 6-29. ATA/CF Sustained Ultra DMA Data-In Data Transfer Timing

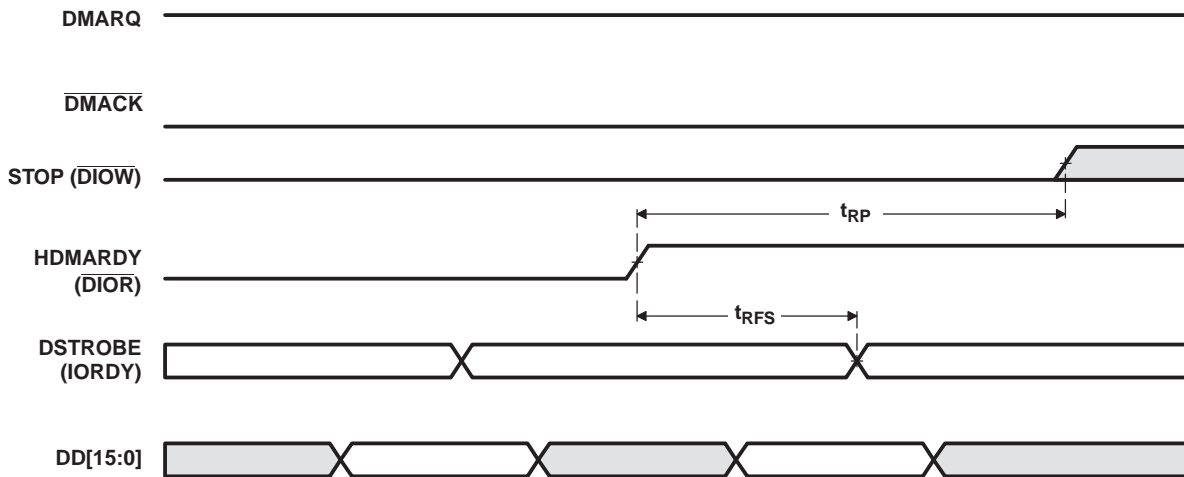

Figure 6-30. ATA/CF Host Pausing an Ultra DMA Data-In Burst Timing

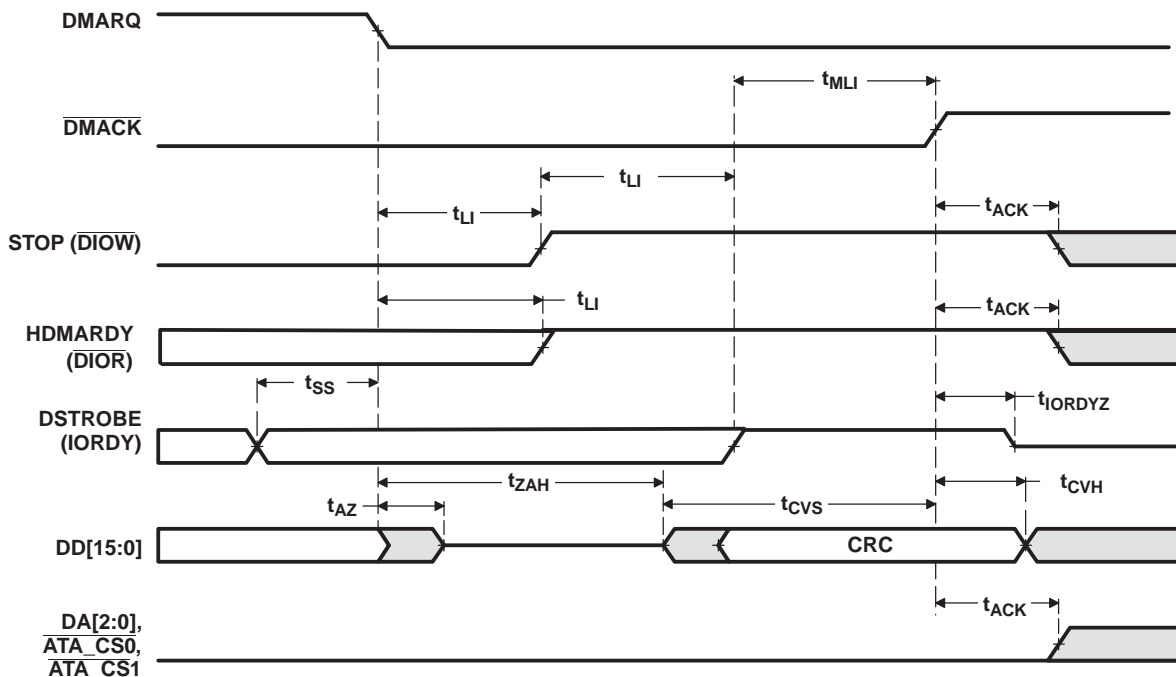

Figure 6-31. ATA/CF Device Terminating an Ultra DMA Data-In Burst Timing

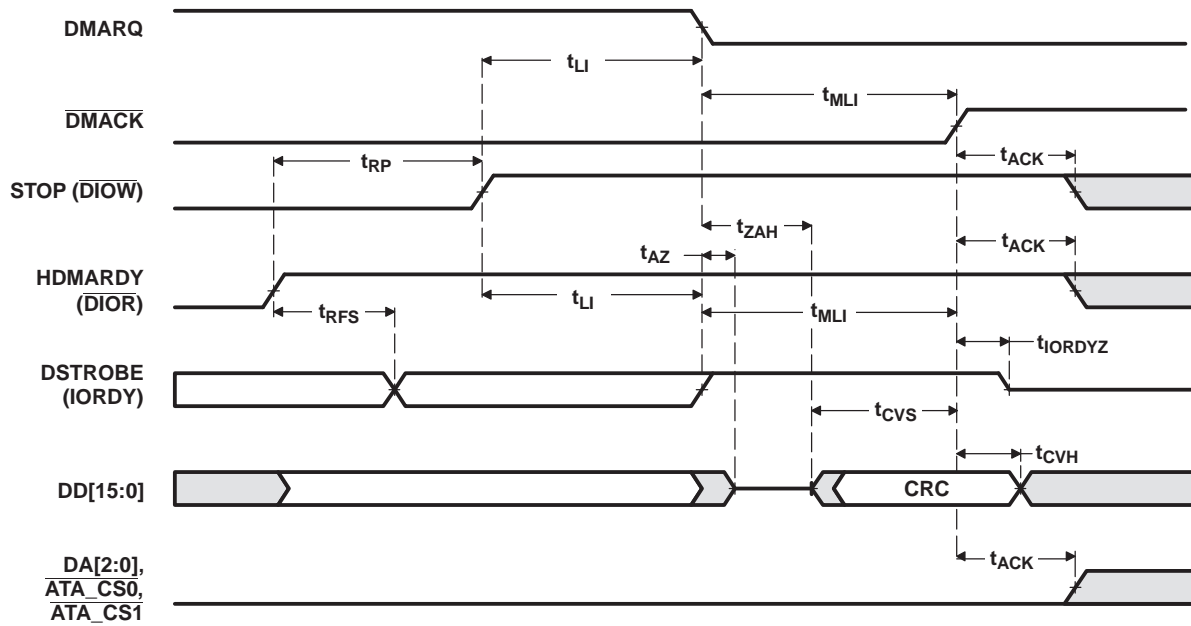
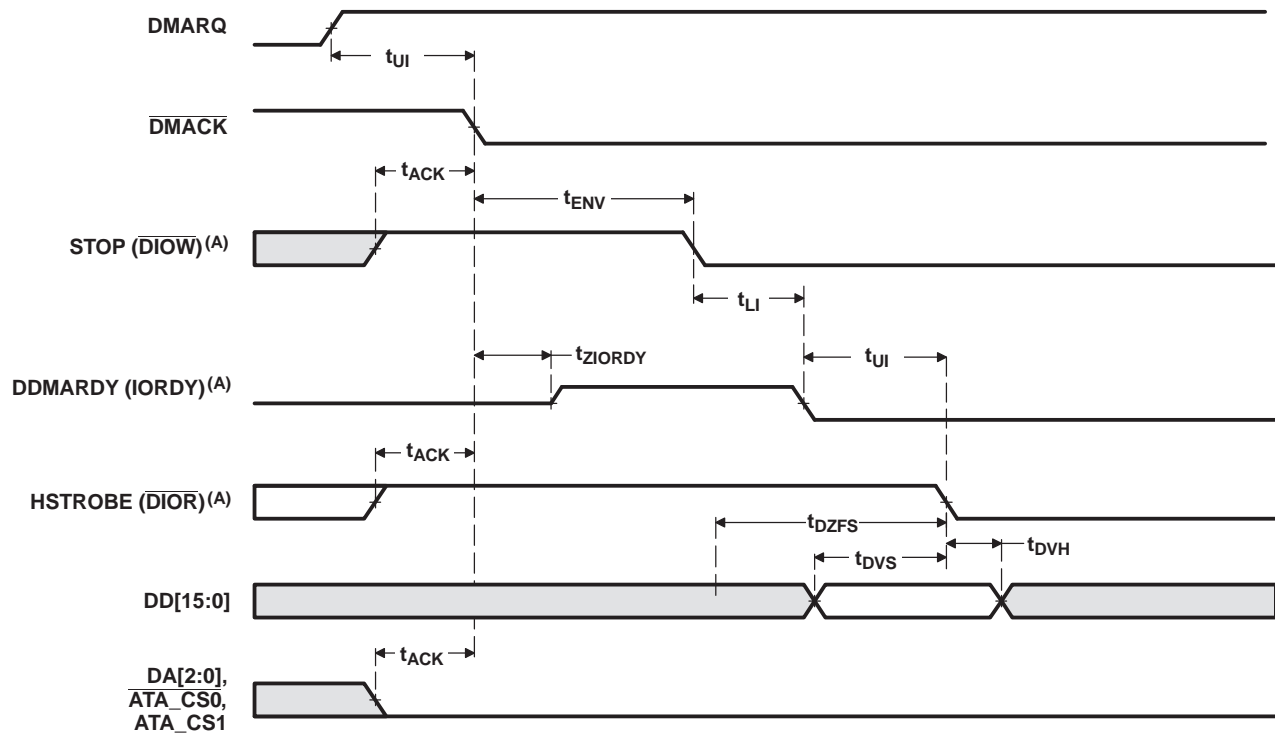
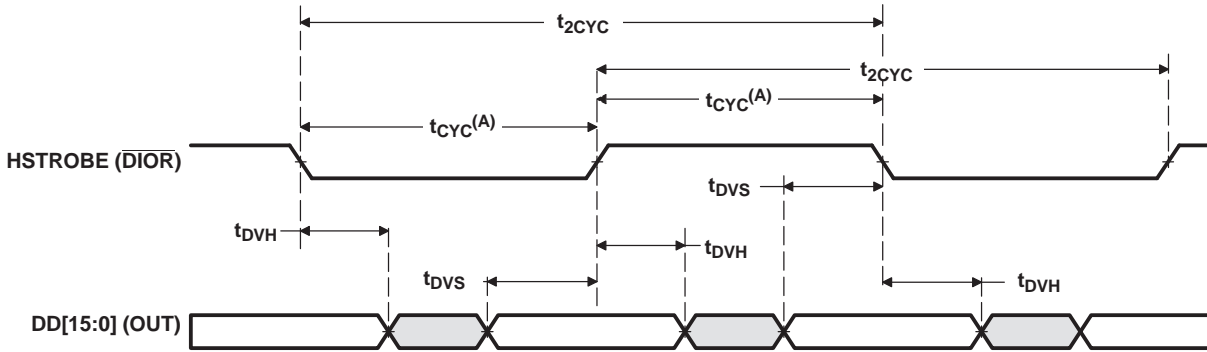

Figure 6-32. ATA/CF Host Terminating an Ultra DMA Data-In Burst Timing



A. The definitions for the  $\overline{DIOW}$ :STOP, IORDY:DDMARDY, and  $\overline{DIOR}$ :HSTROBE signal lines are not in effect until DMARQ and DMACK are asserted.

Figure 6-33. ATA/CF Initiating an Ultra DMA Data-Out Burst Timing



- A. While HSTROBE ( $\overline{\text{DIOR}}$ ) timing is  $t_{\text{CYC}}$  at the host, it may be different at the device due to propagation delay differences on the cable.

Figure 6-34. ATA/CF Sustained Ultra DMA Data-Out Transfer Timing

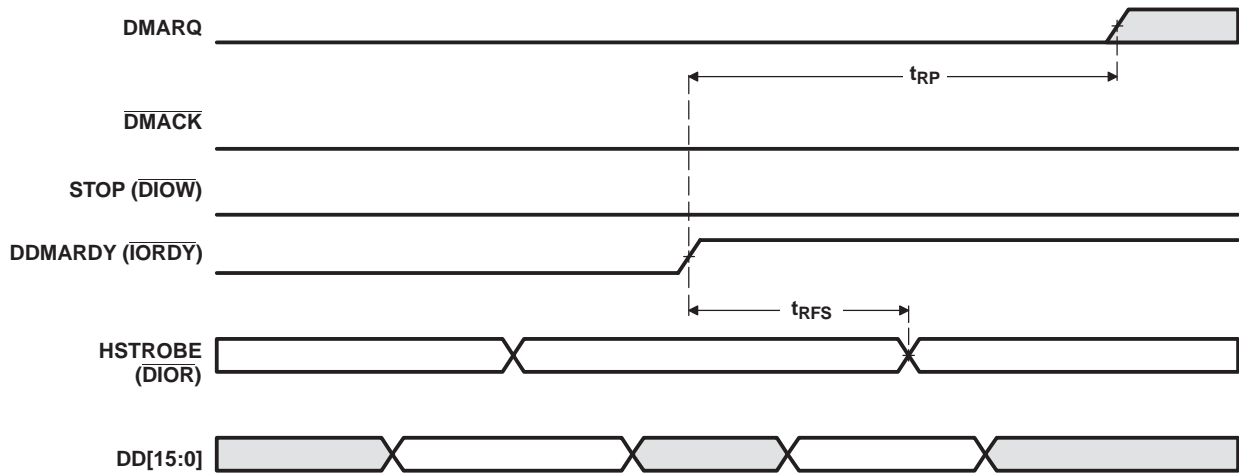

Figure 6-35. ATA/CF Device Pausing an Ultra DMA Data-Out Burst Timing

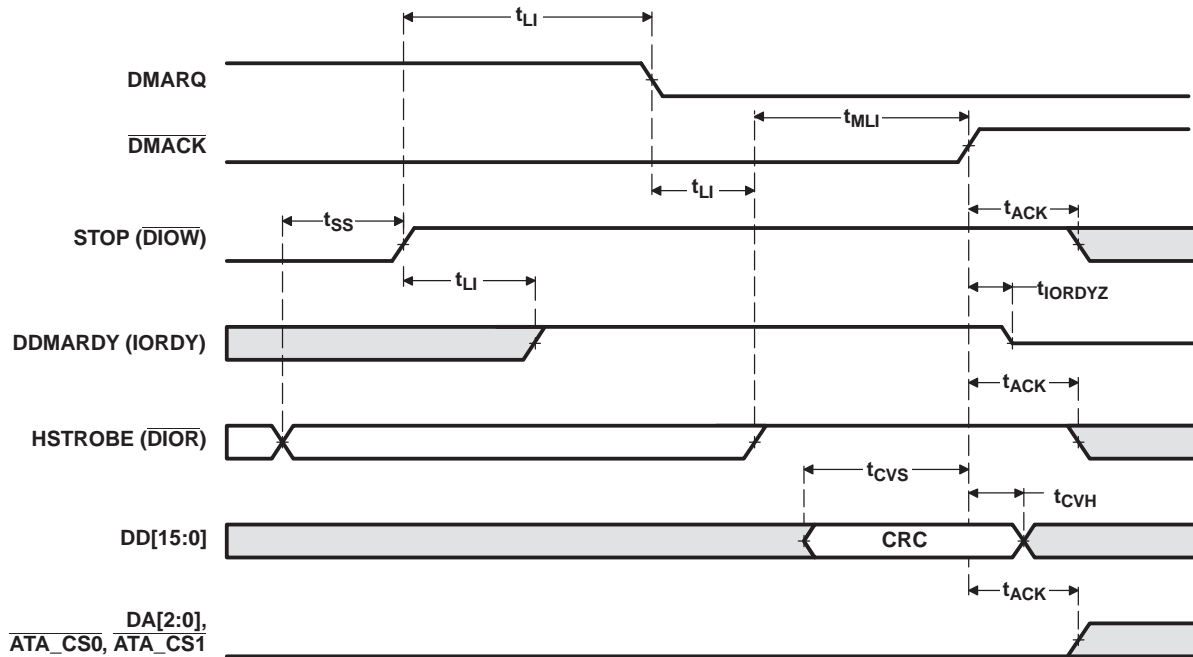

Figure 6-36. ATA/CF Host Terminating an Ultra DMA Data-Out Burst Timing

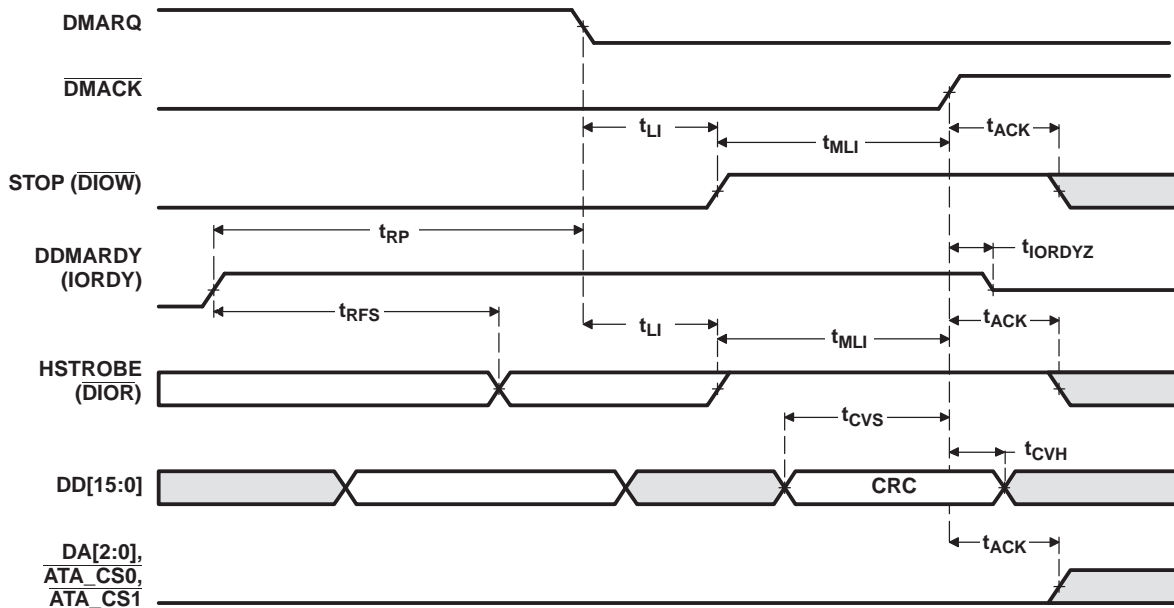

Figure 6-37. ATA/CF Device Terminating an Ultra DMA Data-Out Burst Timing

6.11.2.4 ATA/CF HDDIR Timing

Figure 6-38 through Figure 6-41 show the behavior of HDDIR for the different types of transfers.

Table 6-42. Timing Requirements for HDDIR<sup>(1)</sup>

NO.		MIN	MAX	UNIT
1	$t_c$ Cycle time, $\overline{\text{ATA\_CS}}[1:0]$ to HDDIR low	E - 3.1	2.1	ns

(1) E = ATA clock cycle

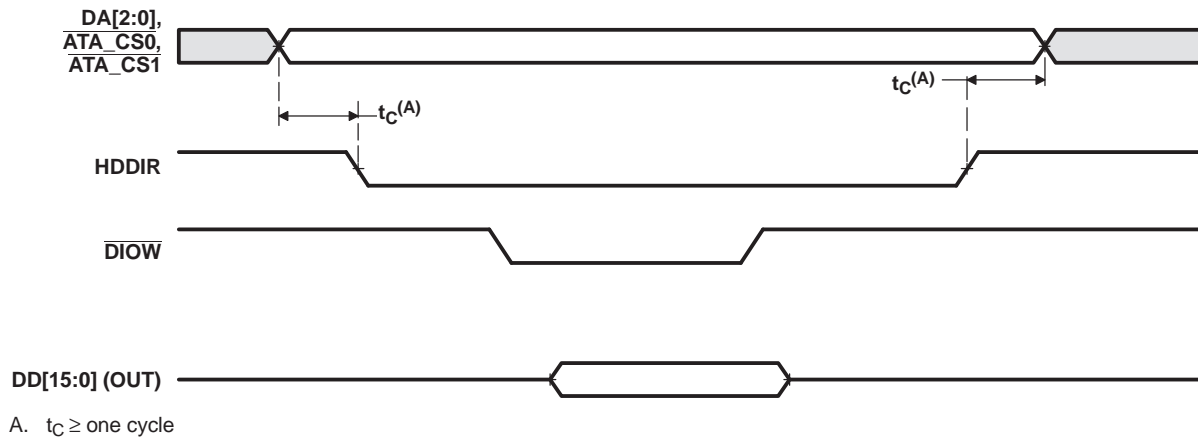

Figure 6-38. ATA/CF HDDIR Taskfile Write/Single PIO Write Timing

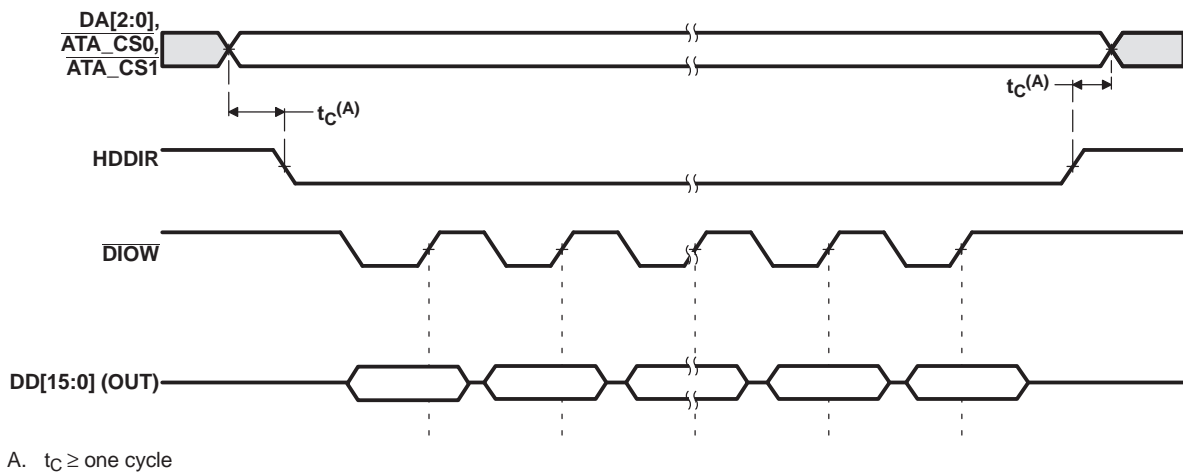
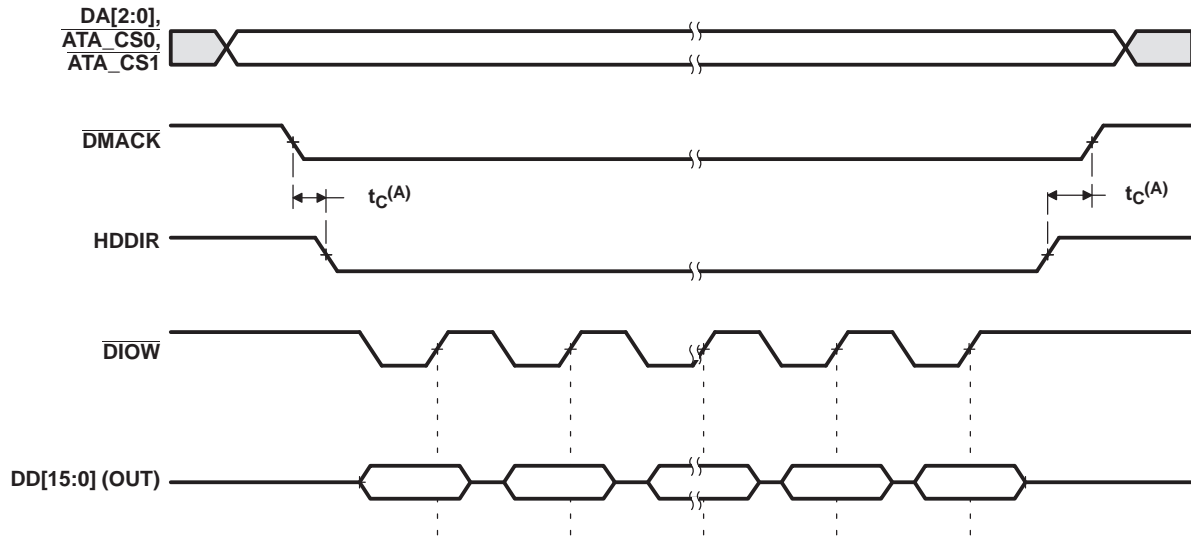
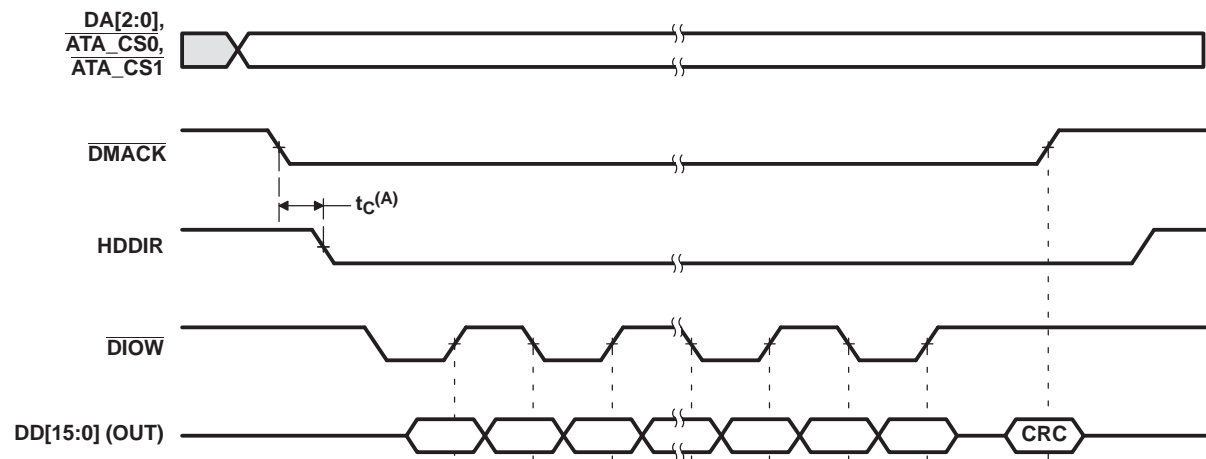

Figure 6-39. ATA/CF HDDIR PIO Postwrite Start Timing



A.  $t_C \geq$  one cycle

Figure 6-40. ATA/CF HDDIR Multiword DMA Write Transfer Timing



A.  $t_C \geq$  one cycle

Figure 6-41. ATA/CF HDDIR Ultra DMA Write Transfer Timing



## 6.12 MMC/SD/SDIO

The DM6446 MMC/SD/SDIO Controller has following features:

- MultiMediaCard (MMC).
- Secure Digital (SD) memory card with Secure Data I/O (SDIO).
- MMC/SD/SDIO protocol support.
- Programmable clock frequency.
- 256 bit Read/Write FIFO to lower system overhead.
- Slave DMA transfer capability.

SDIO is only supported for WLAN operation through TI third parties. For more information about third-party WLAN products, go to <http://www.ti.com.davinciwlan>.

The MMC/SD/SDIO register memory mapping is shown in [Table 6-43](#).

### 6.12.1 MMC/SD/SDIO Peripheral Description(s)

**Table 6-43. MMC/SD/SDIO Register Descriptions**

HEX ADDRESS RANGE	ACRONYM	REGISTER NAME
0x01E1 0000	MMCCTL	MMC Control Register
0x01E1 0004	MMCCLK	MMC Memory Clock Control Register
0x01E1 0008	MMCST0	MMC Status Register 0
0x01E1 000C	MMCST1	MMC Status Register 1
0x01E1 0010	MMCIM	MMC Interrupt Mask Register
0x01E1 0014	MMCTOR	MMC Response Time-Out Register
0x01E1 0018	MMCTOD	MMC Data Read Time-Out Register
0x01E1 001C	MMCBLEN	MMC Block Length Register
0x01E1 0020	MMCNBLK	MMC Number of Blocks Register
0x01E1 0024	MMCNBLC	MMC Number of Blocks Counter Register
0x01E1 0028	MMCDRR	MMC Data Receive Register
0x01E1 002C	MMCDXR	MMC Data Transmit Register
0x01E1 0030	MMCCMD	MMC Command Register
0x01E1 0034	MMCARGL	MMC Argument Register
0x01E1 0038	MMCRSP01	MMC Response Register 0 and 1
0x01E1 003C	MMCRSP23	MMC Response Register 2 and 3
0x01E1 0040	MMCRSP45	MMC Response Register 4 and 5
0x01E1 0044	MMCRSP67	MMC Response Register 6 and 7
0x01E1 0048	MMCDRSP	MMC Data Response Register
0x01E1 004C - 0x01E1 004F	-	Reserved
0x01E1 0050	MMCCIDX	MMC Command Index Register
0x01E1 0054 - 0x01E1 0063	-	Reserved
0x01E1 0064 - 0x01E1 006C	SDIO	
0x01E1 0070	-	Reserved
0x01E1 0074	MMCFIFOCTL	MMC FIFO Control Register
0x01E1 0078 - 0x01E1 FFFF	-	Reserved

### 6.12.2 MMC/SD/SDIO Electrical Data/Timing

**Table 6-44. Timing Requirements for MMC/SD/SDIO Module**  
(see Figure 6-43 and Figure 6-45)

NO.			STANDARD MODE		UNIT
			MIN	MAX	
1	$t_{su}(CMDV-CLKH)$	Setup time, SD_CMD valid before SD_CLK high	5		ns
2	$t_h(CLKH-CMDV)$	Hold time, SD_CMD valid after SD_CLK high	5		ns
3	$t_{su}(DATV-CLKH)$	Setup time, SD_DATx valid before SD_CLK high	5		ns
4	$t_h(CLKH-DATV)$	Hold time, SD_DATx valid after SD_CLK high	5		ns

**Table 6-45. Switching Characteristics Over Recommended Operating Conditions for MMC/SD/SDIO Module<sup>(1)</sup>** (see Figure 6-42 through Figure 6-45)

NO.	PARAMETER	STANDARD MODE		UNIT
		MIN	MAX	
7	$f_{(CLK)}$	0	25	MHz
8	$f_{(CLK\_ID)}$	0	400	KHz
9	$t_w(CLKL)$	10		ns
10	$t_w(CLKH)$	10		ns
11	$t_r(CLK)$		10	ns
12	$t_f(CLK)$		10	ns
13	$t_d(CLKLL-CMD)$	-7.5	13	ns
14	$t_{dis}(CLKL-DAT)$	-7.5	13	ns

(1) P = Period of SD\_CLK (SYSCLK5), in nanoseconds (ns).

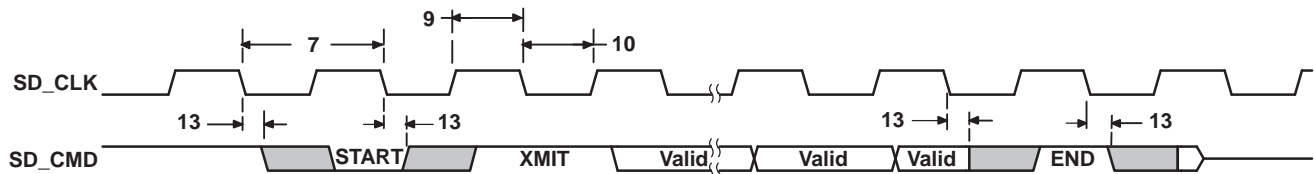

**Figure 6-42. MMC/SD/SDIO Host Command Timing**

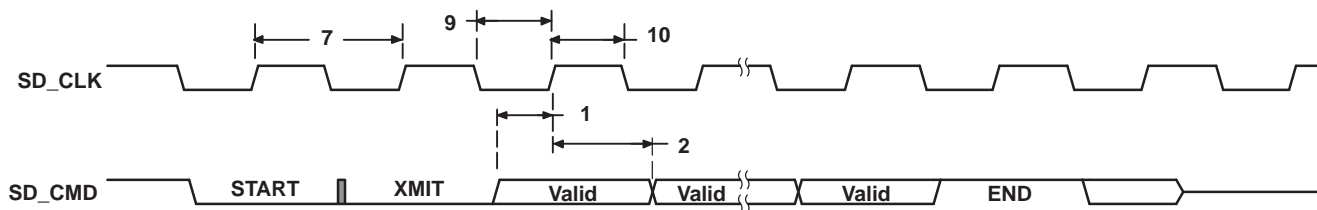

**Figure 6-43. MMC/SD/SDIO Card Response Timing**

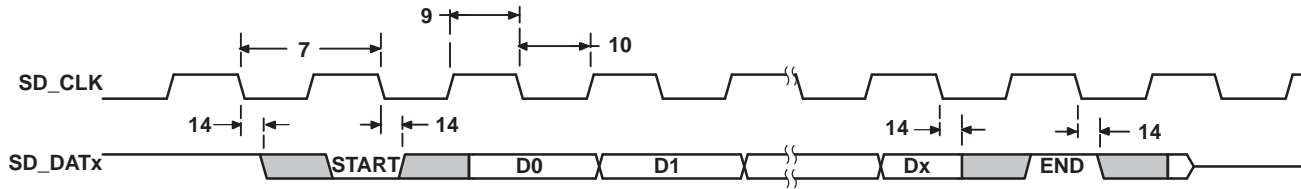

Figure 6-44. MMC/SD/SDIO Host Write Timing

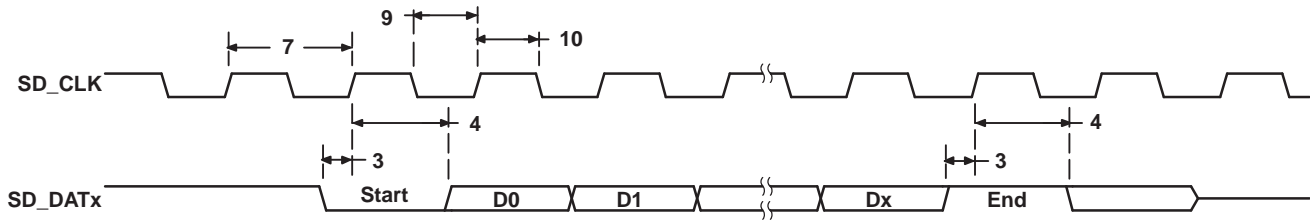

Figure 6-45. MMC/SD/SDIO Host Read and Card CRC Status Timing

### 6.13 Video Processing Sub-System (VPSS) Overview

The DM6446 Video Processing Sub-System (VPSS) provides a Video Processing Front End (VPFE) input interface for external imaging peripherals (i.e., image sensors, video decoders, etc.) and a Video Processing Back End (VPBE) output interface for display devices, such as analog SDTV displays, digital LCD panels, HDTV video encoders, etc.

**Note:** The VPSS module is supported with Linux Application Peripheral Interfaces (APIs) commonly used by video application developers. Video for Linux 2 or V4L2 uses APIs commonly used for video capture. The typical use cases of the VPSS Video Front-End (VPFE) have been ported to this Linux API structure. V4L2 supports standard video interfaces such as: BT.656 and Y/C mode. Other modules within the VPSS VPFE for example, the Preview Engine, H3A, and Histogram are *not* currently supported within the software APIs. The VPSS Back-End (VPBE) uses FBDev/DirectFB as the APIs. Certain functionalities within the VPBE have not been implemented in the FBDev/DirectFB APIs. For modes/functions not implemented in software, it is the user's responsibility to modify the software drivers/APIs.

The VPSS register memory mapping is shown in [Table 6-46](#).

**Table 6-46. VPSS Register Descriptions**

HEX ADDRESS RANGE	REGISTER ACRONYM	DESCRIPTION
0x01C7 3400	PID	Peripheral Revision and Class Information
0x01C7 3404	PCR	VPSS Control Register
0x01C7 3408	-	Reserved
0x01C7 3508	SDR_REG_EXP	SDRAM Non Real-Time Read Request Expand
0x01C7 350C - 0x01C7 3FFF	-	Reserved

To ensure NTSC- and PAL-compliant output video, the stability of the input clock source is very important. TI recommends a 27-MHz, 50-ppm crystal. Ceramic oscillators are not recommended. The NTSC/PAL color sub-carrier frequency is derived from the 27-MHz clock. Therefore, if the 27-MHz clock drifts, then the color sub-carrier frequency will drift as well. Assuming no 27-MHz frequency drift, the color sub-carrier frequency is generated as follows:

$$f_{sc-ntsc} = 27 \text{ MHz} \left( \frac{35}{264} \right) = 3.5795454545 \text{ MHz}$$

$$f_{sc-pal} = 27 \text{ MHz} \left( \frac{167}{1017} \right) = 4.4332628318 \text{ MHz}$$

To ensure the color sub-carrier frequency will not drift out of spec, the user must follow the crystal requirements discussed in [Section 6.5.1](#), *Clock Input Option 1 – Crystal or Ceramic Resonator*. Alternatively, if the VPBE input clock is sourced from the VPBECLK or VPFE clock inputs, these clocks must have a frequency stability of  $\pm 50$  ppm to ensure the NTSC and PAL compliant output video.

### 6.13.1 Video Processing Front-End (VPFE)

The Video Processing Front-End (VPFE) consists of the CCD Controller (CCDC), Preview Engine, Resizer, Hardware 3A (H3A) Statistic Generator, and Histogram blocks. Together, these modules provide DM6446 with a powerful and flexible front-end interface. These modules are briefly described below:

- The CCDC provides an interface to image sensors and digital video sources.
- The Preview Engine is a parameterized hardwired image processing block which is used for converting RAW color data from a Bayer pattern to YUV 4:2:2.
- The Resizer module re-sizes the input image data to the desired display or video encoding resolution
- The H3A module provides control loops for Auto Focus (AF), Auto White Balance (AWB) and Auto Exposure (AE).
- The Histogram module bins input color pixels, depending on the amplitude, and provides statistics required to implement various 3A (AE/AF/AWB) algorithms and tune the final image/video output.

The VPFE register memory mapping is shown in [Table 6-47](#).

**Table 6-47. VPFE Register Address Range Descriptions**

HEX ADDRESS RANGE	ACRONYM	REGISTER NAME
0x01C7 0400 – 0x01C7 07FF	CCDC	VPFE – CCD Controller
0x01C7 0800 – 0x01C7 0BFF	PREV	VPFE – Preview Engine/Image Signal Processor
0x01C7 0C00 – 0x01C7 09FF	RESZ	VPFE – Resizer
0x01C7 1000 – 0x01C7 13FF	HIST	VPFE – Histogram
0x01C7 1400 – 0x01C7 17FF	H3A	VPFE – Hardware 3A (Auto-Focus/WB/Exposure)
0x01C7 3400 – 0x01C7 3FFF	VPSS	VPSS Shared Buffer Logic Registers

#### 6.13.1.1 CCD Controller (CCDC)

The CCDC receives raw image/video data from sensors (CMOS or CCD) or YUV video data in numerous formats from video decoder devices. The following features are supported by the CCDC module.

- Conventional Bayer pattern formats.
- Generates HD/VD timing signals and field ID to an external timing generator or can synchronize to an external timing generator.
- Interface to progressive and interlaced sensors.
- REC656/CCIR-656 standard (YCbCr 4:2:2 format, either 8- or 16-bit).
- YCbCr 4:2:2 format, either 8- or 16-bit with discrete H and VSYNC signals.
- Up to 16-bit input.
- Optical black clamping signal generation.
- Shutter signal control.
- Digital clamping and black level compensation.
- 10-bit to 8-bit A-law compression.
- Low-pass filter prior to writing to SDRAM. If this filter is enabled, 2 pixels each in the left and right edges of each line are cropped from the output.
- Output range from 16-bits to 8-bits wide (8-bits wide allows for 50% saving in storage area).
- Downsampling via programmable culling patterns.
- Control output to the DDR2 via an external write enable signal.
- Up to 16K pixels (image size) in both the horizontal and vertical direction.

The CCDC register memory mapping is shown in [Table 6-48](#).

**Table 6-48. CCDC Register Descriptions**

HEX ADDRESS RANGE	REGISTER ACRONYM	DESCRIPTION
0x01C7 0400	PID	Peripheral Revision and Class Information
0x01C7 0404	PCR	Peripheral Control Register
0x01C7 0408	SYN_MODE	SYNC and Mode Set Register
0x01C7 040C	HD_VD_WID	HD and VD Signal Width
0x01C7 0410	PIX_LINES	Number of Pixels in a Horizontal Line and Number of Lines in a Frame
0x01C7 0414	HORZ_INFO	Horizontal Pixel Information
0x01C7 0418	VERT_START	Vertical Line - Settings for the Starting Pixel
0x01C7 041C	VERT_LINES	Number of Vertical Lines
0x01C7 0420	CULLING	Culling Information in Horizontal and Vertical Directions
0x01C7 0424	HSIZE_OFF	Horizontal Size
0x01C7 0428	SDOFST	SDRAM/DDRAM Line Offset
0x01C7 042C	SDR_ADDR	SDRAM Address
0x01C7 0430	CLAMP	Optical Black Clamping Settings
0x01C7 0434	DCSUB	DC Clamp
0x01C7 0438	COLPTN	CCD Color Pattern
0x01C7 043C	BLKCOMP	Black Compensation
0x01C7 0440	-	Reserved
0x01C7 0444	-	Reserved
0x01C7 0448	VDINT	VD Interrupt Timing
0x01C7 044C	ALAW	A-Law Setting
0x01C7 0450	REC656IF	REC656 Interface
0x01C7 0454	CCDCFG	CCD Configuration
0x01C7 0458	FMTCFG	Data Reformatter/Video Port Configuration
0x01C7 045C	FMT_HORZ	Data Reformatter/Video Input Interface Horizontal Information
0x01C7 0460	FMT_VERT	Data Reformatter/Video Input Interface Vertical Information
0x01C7 0464	FMT_ADDR0	Address Pointer 0 Setup
0x01C7 0468	FMT_ADDR1	Address Pointer 1 Setup
0x01C7 046C	FMT_ADDR2	Address Pointer 2 Setup
0x01C7 0470	FMT_ADDR3	Address Pointer 3 Setup
0x01C7 0474	FMT_ADDR4	Address Pointer 4 Setup
0x01C7 0478	FMT_ADDR5	Address Pointer 5 Setup
0x01C7 047C	FMT_ADDR6	Address Pointer 6 Setup
0x01C7 0480	FMT_ADDR7	Address Pointer 7 Setup
0x01C7 0484	PRGEVEN_0	Program Entries 0-7 for Even Line
0x01C7 0488	RRGEVEN_1	Program Entries 8-15 for Even Line
0x01C7 048C	PRGODD_0	Program Entries 0-7 for Odd Line
0x01C7 0490	PRGODD_1	Program Entries 8-15 for Odd Line
0x01C7 0494	VP_OUT	Video Port Output Settings

### 6.13.1.2 Preview Engine

The preview engine transforms raw unprocessed image/video data from a sensor (CMOS or CCD) into YCbCr 4:2:2 data. The output of the preview engine is used for both video compression and external display devices such as a NTSC/PAL analog encoder or a digital LCD. The following features are supported by the preview engine.

- Accepts conventional Bayer pattern formats.
- Input image/video data from either the CCD/CMOS controller or the DDR2 memory.
- Output width up to 1280 pixels wide.

- Automatic/mandatory cropping of pixels/lines when edge processing is performed. If all the corresponding modules are enabled, a total of 14 pixels per line (7 left most and 7 right most) and 8 lines (4 top most and 4 bottom most) will not be output.
- Simple horizontal averaging (by factors of 2, 4, or 8) to handle input widths that are greater than 1280 (plus the cropped number) pixels wide.
- Dark frame capture to DDR2.
- Dark frame subtraction for every input raw data frame, fetched from DDR2, pixel-by-pixel to improve video quality.
- Lens shading compensation. Each input pixel is multiplied with a corresponding 8-bit gain value and the result is right shifted by a programmable parameter (0-7 bits).
- A-law decompression to transform non-linear 8-bit data to 10-bit linear data. This feature allows data in DDR2 to be 8-bits, which saves 50% of the area if the input to the preview engine is from the DDR2.
- Horizontal median filter for reducing temperature induced noise in pixels.
- Programmable noise filter that operates on a 3x3 grid of the same color (effectively, this is a five line storage requirement).
- Digital gain and white balance (color separate gain for white balance).
- Programmable CFA interpolation that operates on a 5x5 grid.
- Conventional Bayer pattern RGB and complementary color sensors.
- Support for an image that is downsampled by 2x in the horizontal direction (with and without phase correction). In this case, the image is 2/3 populated instead of the conventional 1/3 colors.
- Support for an image that is downsampled by 2x in both the horizontal and vertical direction. In this case, the image is fully populated instead of the conventional 1/3 colors.
- Programmable RGB-to-RGB blending matrix (9 coefficients for the 3x3 matrix).
- Fully programmable gamma correction (1024 entries for each color held in an on-chip RAM).
- Programmable color conversion (RGB to YUV) coefficients (9 coefficients for the 3x3 matrix).
- Luminance enhancement (non-linear) and chrominance suppression & offset.

The Preview Engine register memory mapping is shown in [Table 6-49](#).

**Table 6-49. Preview Engine Register Descriptions**

HEX ADDRESS RANGE	REGISTER ACRONYM	DESCRIPTION
0x01C7 0800	PID	Peripheral Revision and Class Information
0x01C7 0804	PCR	Peripheral Control Register
0x01C7 0808	HORZ_INFO	Horizontal Information/Setup
0x01C7 080C	VERT_INFO	Vertical Information/Setup
0x01C7 0810	RSDR_ADDR	Read Address From SDRAM
0x01C7 0814	RADR_OFFSET	Line Offset for the Read Data
0x01C7 0818	DSDR_ADDR	Dark Frame Address From SDRAM
0x01C7 081C	DRKF_OFFSET	Line Offset for the Dark Frame Data
0x01C7 0820	WSDR_ADDR	Write Address to the SDRAM
0x01C7 0824	WADD_OFFSET	Line Offset for the Write Data
0x01C7 0828	AVE	Input Formatter/Averager
0x01C7 082C	HMED	Horizontal Median Filter
0x01C7 0830	NF	Noise Filter
0x01C7 0834	WB_DGAIN	White Balance Digital Gain
0x01C7 0838	WBGAIN	White Balance Coefficients
0x01C7 083C	WBSEL	White Balance Coefficients Selection
0x01C7 0840	CFA	CFA Register
0x01C7 0844	BLKADJOFF	Black Adjustment Offset

**Table 6-49. Preview Engine Register Descriptions (continued)**

HEX ADDRESS RANGE	REGISTER ACRONYM	DESCRIPTION
0x01C7 0848	RGB_MAT1	RGB2RGB Blending Matrix Coefficients
0x01C7 084C	RGB_MAT2	RGB2RGB Blending Matrix Coefficients
0x01C7 0850	RGB_MAT3	RGB2RGB Blending Matrix Coefficients
0x01C7 0854	RGB_MAT4	RGB2RGB Blending Matrix Coefficients
0x01C7 0858	RGB_MAT5	RGB2RGB Blending Matrix Coefficients
0x01C7 085C	RGB_OFF1	RGB2RGB Blending Matrix Offsets
0x01C7 0860	RGB_OFF2	RGB2RGB Blending Matrix Offsets
0x01C7 0864	CSC0	Color Space Conversion Coefficients
0x01C7 0868	CSC1	Color Space Conversion Coefficients
0x01C7 086C	CSC2	Color Space Conversion Coefficients
0x01C7 0870	CSC_OFFSET	Color Space Conversion Offsets
0x01C7 0874	CNT_BRT	Contrast and Brightness Settings
0x01C7 0878	CSUP	Chrominance Suppression Settings
0x01C7 087C	SETUP_YC	Maximum/Minimum Y and C Settings
0x01C7 0880	SET_TBL_ADDRESS	Setup Table Addresses
0x01C7 0884	SET_TBL_DATA	Setup Table Data

### 6.13.1.3 Resizer

The resizer module can accept input image/video data from either the preview engine or DDR2. The output of the resizer module is sent to DDR2. The following features are supported by the resizer module.

- An output width up to 1280 horizontal pixels.
- Input from external DDR2.
- Up to 4x upsampling (digital zoom).
- Bi-cubic interpolation (4-tap horizontal, 4-tap vertical) can be implemented with the programmable filter coefficients.
- 8 phases of filter coefficients.
- Optional bi-linear interpolation for the chrominance components.
- Up to 1/4x downsampling
- 4-tap horizontal and 4-tap vertical filter coefficients (with 8-phases) for 1x to 1/2x downsampling
- 1/2x to 1/4x downsampling, for 7-tap mode with 4-phases.
- Resizing either YUV 4:2:2 packed data (16-bits) or color separate data (8-bit data within DDR) that is contiguous.
- Separate/independent resizing factor for the horizontal and vertical directions.
- Upsampling and downsampling ratios that are available are: 256/N, with N ranging from 64 to 1024.
- Programmable luminance sharpening after the horizontal resizing and before the vertical resizing step.

The Resizer register memory mapping is shown in [Table 6-50](#).

**Table 6-50. Resizer Register Descriptions**

HEX ADDRESS RANGE	REGISTER ACRONYM	DESCRIPTION
0x01C7 0C00	PID	Peripheral Revision and Class Information
0x01C7 0C04	PCR	Peripheral Control Register
0x01C7 0C08	RSZ_CNT	Resizer Control Bits
0x01C7 0C0C	OUT_SIZE	Output Width and Height After Resizing
0x01C7 0C10	IN_START	Input Starting Information
0x01C7 0C14	IN_SIZE	Input Width and Height Before Resizing
0x01C7 0C18	SDR_INADD	Input SDRAM Address



**Table 6-50. Resizer Register Descriptions (continued)**

HEX ADDRESS RANGE	REGISTER ACRONYM	DESCRIPTION
0x01C7 0C1C	SDR_INOFF	SDRAM Offset for the Input Line
0x01C7 0C20	SDR_OUTADD	Output SDRAM Address
0x01C7 0C24	SDR_OUTOFF	SDRAM Offset for the Output Line
0x01C7 0C28	HFILT10	Horizontal Filter Coefficients 1 and 0
0x01C7 0C2C	HFILT32	Horizontal Filter Coefficients 3 and 2
0x01C7 0C30	HFILT54	Horizontal Filter Coefficients 5 and 4
0x01C7 0C34	HFILT76	Horizontal Filter Coefficients 7 and 6
0x01C7 0C38	HFILT98	Horizontal Filter Coefficients 9 and 8
0x01C7 0C3C	HFILT1110	Horizontal Filter Coefficients 11 and 10
0x01C7 0C40	HFILT1312	Horizontal Filter Coefficients 13 and 12
0x01C7 0C44	HFILT1514	Horizontal Filter Coefficients 15 and 14
0x01C7 0C48	HFILT1716	Horizontal Filter Coefficients 17 and 16
0x01C7 0C4C	HFILT1918	Horizontal Filter Coefficients 19 and 18
0x01C7 0C50	HFILT2120	Horizontal Filter Coefficients 21 and 20
0x01C7 0C54	HFILT2322	Horizontal Filter Coefficients 23 and 22
0x01C7 0C58	HFILT2524	Horizontal Filter Coefficients 25 and 24
0x01C7 0C5C	HFILT2726	Horizontal Filter Coefficients 27 and 26
0x01C7 0C60	HFILT2928	Horizontal Filter Coefficients 29 and 28
0x01C7 0C64	HFILT3130	Horizontal Filter Coefficients 31 and 30
0x01C7 0C68	VFILT10	Vertical Filter Coefficients 1 and 0
0x01C7 0C6C	VFILT32	Vertical Filter Coefficients 3 and 2
0x01C7 0C70	VFILT54	Vertical Filter Coefficients 5 and 4
0x01C7 0C74	VFILT76	Vertical Filter Coefficients 7 and 6
0x01C7 0C78	VFILT98	Vertical Filter Coefficients 9 and 8
0x01C7 0C7C	VFILT1110	Vertical Filter Coefficients 11 and 10
0x01C7 0C80	VFILT1312	Vertical Filter Coefficients 13 and 12
0x01C7 0C84	VFILT1514	Vertical Filter Coefficients 15 and 14
0x01C7 0C88	VFILT1716	Vertical Filter Coefficients 17 and 16
0x01C7 0C8C	VFILT1918	Vertical Filter Coefficients 19 and 18
0x01C7 0C90	VFILT2120	Vertical Filter Coefficients 21 and 20
0x01C7 0C94	VFILT2322	Vertical Filter Coefficients 23 and 22
0x01C7 0C98	VFILT2524	Vertical Filter Coefficients 25 and 24
0x01C7 0C9C	VFILT2726	Vertical Filter Coefficients 27 and 26
0x01C7 0CA0	VFILT2928	Vertical Filter Coefficients 29 and 28
0x01C7 0CA4	VFILT3130	Vertical Filter Coefficients 31 and 30
0x01C7 0CA8	YENH	Luminance Enhancer

#### 6.13.1.4 Hardware 3A (H3A)

The Hardware 3A (H3A) module provides control loops for Auto Focus, Auto White Balance and Auto Exposure. There are 2 main components of the H3A module:

- Auto Focus (AF) Engine
- Auto Exposure (AE) & Auto White Balance (AWB) Engine

The AF engine extracts and filters the red, green, and blue data from the input image/video data and provides either the accumulation or peaks of the data in a specified region. The specified region is a two dimensional block of data and is referred to as a “paxel” for the case of AF.

The AE/AWB Engine accumulates the values and checks for saturated values in a sub sampling of the video data. In the case of the AE/AWB, the two-dimensional block of data is referred to as a “window”. The number, dimensions, and starting position of the AF paxels and the AE/AWB windows are separately programmable.

The H3A register memory mapping is shown in [Table 6-51](#).

**Table 6-51. H3A Register Descriptions**

HEX ADDRESS RANGE	REGISTER ACRONYM	DESCRIPTION
0x01C7 1400	PID	Peripheral Revision and Class Information
0x01C7 1404	PCR	Peripheral Control Register
0x01C7 1408	AFPAX1	Setup for the AF Engine Paxel Configuration
0x01C7 140C	AFPAX2	Setup for the AF Engine Paxel Configuration
0x01C7 1410	AFPAXSTART	Start Position for AF Engine Paxels
0x01C7 1414	AFIRSH	Start Position for IIRSH
0x01C7 1418	AFBUFST	SDRAM/DDRAM Start Address for AF Engine
0x01C7 141C	AFCOEF010	IIR Filter Coefficient Data for SET 0
0x01C7 1420	AFCOEF032	IIR Filter Coefficient Data for SET 0
0x01C7 1424	AFCOEFF054	IIR Filter Coefficient Data for SET 0
0x01C7 1428	AFCOEFF076	IIR Filter Coefficient Data for SET 0
0x01C7 142C	AFCOEFF098	IIR Filter Coefficient Data for SET 0
0x01C7 1430	AFCOEFF0010	IIR Filter Coefficient Data for SET 0
0x01C7 1434	AFCOEF110	IIR Filter Coefficient Data for SET 1
0x01C7 1438	AFCOEF132	IIR Filter Coefficient Data for SET 1
0x01C7 143C	AFCOEFF154	IIR Filter Coefficient Data for SET 1
0x01C7 1440	AFCOEFF176	IIR Filter Coefficient Data for SET 1
0x01C7 1444	AFCOEFF198	IIR Filter Coefficient Data for SET 1
0x01C7 1448	AFCOEFF1010	IIR Filter Coefficient Data for SET 1
0x01C7 144C	AEWWIN1	Configuration for AE/AWB Windows
0x01C7 1450	AEWINSTART	Start Position for AE/AWB Windows
0x01C7 1454	AEWINBLK	Start Position and Height for Black Line of AE/AWB Windows
0x01C7 1458	AEWSUBWIN	Configuration for Subsample Data in AE/AWB Window
0x01C7 145C	AEWBUFST	SDRAM/DDRAM Start Address for AE/AWB Engine

**6.13.1.4.1 Auto Focus (AF) Engine**

The following features are supported by the Auto Focus (AF) Engine.

- Peak Mode in a Paxel (a Paxel is defined as a two dimensional block of pixels).
- Accumulate the maximum Focus Value of each line in a Paxel
- Accumulation/Sum Mode (instead of Peak mode).
- Accumulate Focus Value in a Paxel.
- Up to 36 Paxels in the horizontal direction and up to 128 Paxels in the vertical direction.
- Programmable width and height for the Paxel. All paxels in the frame will be of same size.
- Programmable red, green, and blue position within a 2x2 matrix.
- Separate horizontal start for paxel and filtering.
- Programmable vertical line increments within a paxel.
- Parallel IIR filters configured in a dual-biquad configuration with individual coefficients (2 filters with 11 coefficients each). The filters are intended to compute the sharpness/peaks in the frame to focus on.

#### 6.13.1.4.2 Auto Exposure (AE) and Auto White Balance (AWB) Engine

The following features are supported by the Auto Exposure (AE) and Auto White Balance (AWB) Engine.

- Accumulate clipped pixels along with all non-saturated pixels.
- Up to 36 horizontal windows.
- Up to 128 vertical windows.
- Programmable width and height for the windows. All windows in the frame will be of same size.
- Separate vertical start coordinate and height for a black row of pixels that is different than the remaining color pixels.
- Programmable Horizontal Sampling Points in a window.
- Programmable Vertical Sampling Points in a window.

#### 6.13.1.5 Histogram

The histogram module accepts raw image/video data and bins the pixels on a value (and color separate) basis. The value of the pixel itself is not stored, but each bin contains the number of pixels that are within the appropriate set range. The source of the raw data for the histogram is typically a CCD/CMOS sensor (via the CCDC module) or optionally from DDR2. The following features are supported by the histogram module.

- Up to four regions/areas.
- Separate horizontal/vertical start and end position for each region.
- Pixels from overlapping regions are accumulated into the highest priority region. The priority is: region0 > region1 > region2 > region3.
- Interface to conventional Bayer pattern. Each region can accumulate either 3 or 4 colors.
- 32, 64, 128, or 256 bins per color per region.
- 32, 64, or 128 bins per color for 2 regions.
- 32 or 64 bins per color for 3 or 4 regions.
- Automatic clear of histogram RAM after an ARM read.
- Saturation of the pixel count if the count exceeds the maximum value (each memory location is 20-bit wide).
- Downshift ranging from 0 to 7 bits (maximum bin range 128).
- The last bin (highest range of values) will accumulate any value that is higher than the lower bound.

The Histogram register memory mapping is shown in [Table 6-52](#).

**Table 6-52. Histogram Register Descriptions**

HEX ADDRESS RANGE	REGISTER ACRONYM	DESCRIPTION
0x01C7 1000	PID	Peripheral Revision and Class Information Register
0x01C7 1004	PCR	Peripheral Control Register
0x01C7 1008	HIST_CNT	Histogram Control Bits Register
0x01C7 100C	WB_GAIN	White/Channel Balance Settings Register
0x01C7 1010	R0_HORZ	Region 0 Horizontal Information Register
0x01C7 1014	R0_VERT	Region 0 Vertical Information Register
0x01C7 1018	R1_HORZ	Region 1 Horizontal Information Register
0x01C7 101C	R1_VERT	Region 1 Vertical Information Register
0x01C7 1020	R2_HORZ	Region 2 Horizontal Information Register
0x01C7 1024	R2_VERT	Region 2 Vertical Information Register
0x01C7 1028	R3_HORZ	Region 3 Horizontal Information Register
0x01C7 102C	R3_VERT	Region 3 Vertical Information Register
0x01C7 1030	HIST_ADDR	Histogram Address for Data to be Read Register
0x01C7 1034	HIST_DATA	Histogram Data That is Read From the Memory Register

**Table 6-52. Histogram Register Descriptions (continued)**

<b>HEX ADDRESS RANGE</b>	<b>REGISTER ACRONYM</b>	<b>DESCRIPTION</b>
0x01C7 1038	RADD	Read Address From DDR2 Memory Register
0x01C7 103C	RADD_OFF	Read Address Offset for Each Line in the DDR2 Memory Register
0x01C7 1040	H_V_INFO	Horizontal/Vertical Information Register (Horizontal/Vertical Number of Pixels When Data is Read From DDR2 Memory Information Register)

### 6.13.1.6 VPFE Electrical Data/Timing

**Table 6-53. Timing Requirements for VPFE PCLK Master/Slave Mode (see Figure 6-46)**

NO.			MIN	MAX	UNIT
1	$t_{c(PCLK)}$	Cycle time, PCLK	10.204 or 13.33 <sup>(1)</sup>	160	ns
2	$t_{w(PCLKH)}$	Pulse duration, PCLK high	4.4		ns
3	$t_{w(PCLKL)}$	Pulse duration, PCLK low	4.4		ns
4	$t_{t(PCLK)}$	Transition time, PCLK		3	ns

(1) When PCLK sources the clock for both the VPFE and VPBE, the minimum cycle time of 13.33 ns (specified in Table 6-60, *Timing Requirements for VPBE CLK Inputs for VPBE*) **must** be met. When PCLK sources the clock for only the VPFE, a minimum cycle time of 10.2 ns may be used.

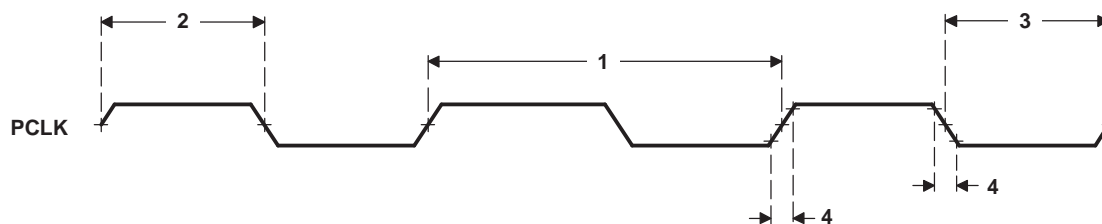

**Figure 6-46. VPFE PCLK Timing**

**Table 6-54. Timing Requirements for VPFE (CCD) Slave Mode<sup>(1)</sup> (see Figure 6-47)**

NO.			MIN	MAX	UNIT
5	$t_{su(CCDV-PCLK)}$	Setup time, CCD valid before PCLK edge		3	ns
6	$t_{h(PCLK-CCDV)}$	Hold time, CCD valid after PCLK edge		2	ns
7	$t_{su(HDV-PCLK)}$	Setup time, HD valid before PCLK edge		3	ns
8	$t_{h(PCLK-HDV)}$	Hold time, HD valid after PCLK edge		2	ns
9	$t_{su(VDV-PCLK)}$	Setup time, VD valid before PCLK edge		3	ns
10	$t_{h(PCLK-VDV)}$	Hold time, VD valid after PCLK edge		2	ns
11	$t_{su(C\_WEV-PCLK)}$	Setup time, C_WE valid before PCLK edge		3	ns
12	$t_{h(PCLK-C\_WEV)}$	Hold time, C_WE valid after PCLK edge		2	ns
13	$t_{su(C\_FIELDV-PCLK)}$	Setup time, C_FIELD valid before PCLK edge		3	ns
14	$t_{h(PCLK-C\_FIELDV)}$	Hold time, C_FIELD valid after PCLK edge		2	ns

(1) The VPFE may be configured to operate in either positive or negative edge clocking mode. When in positive edge clocking mode the rising edge of PCLK is referenced. When in negative edge clocking mode the falling edge of PCLK is referenced.

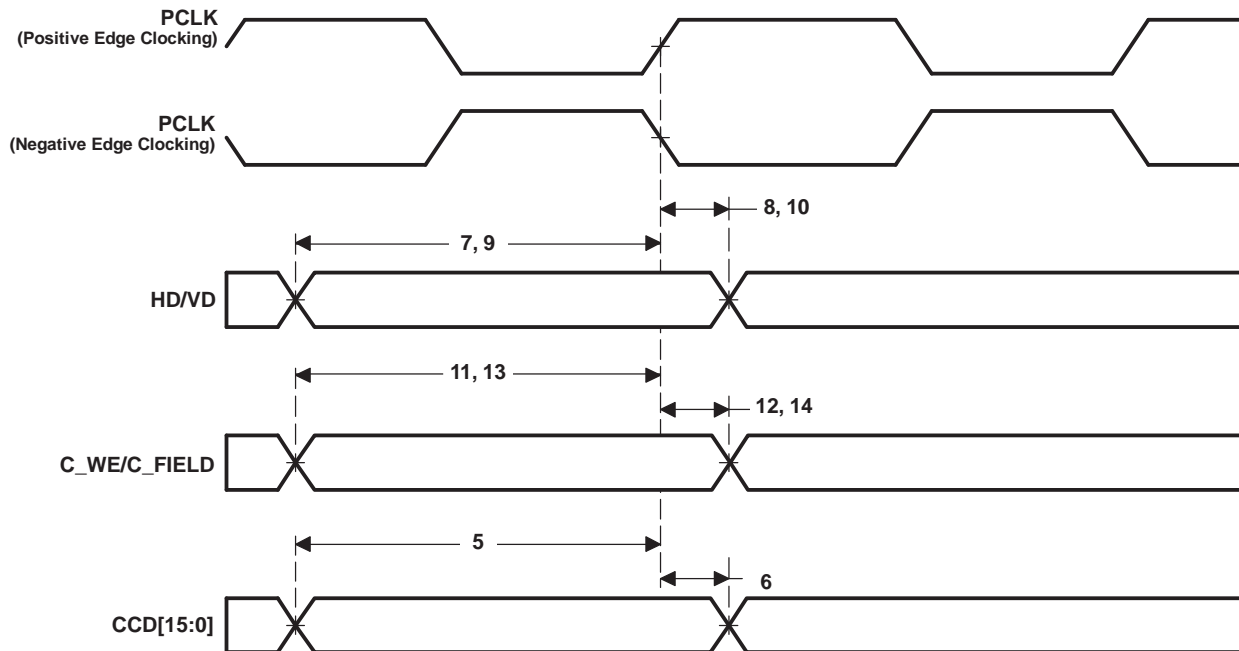

Figure 6-47. VPFE (CCD) Slave Mode Input Data Timing

Table 6-55. Timing Requirements for VPFE (CCD) Master Mode<sup>(1)</sup> (see Figure 6-48)

NO.		MIN	MAX	UNIT
15	$t_{su}(CCDV-PCLK)$ Setup time, CCD valid before PCLK edge	3		ns
16	$t_h(PCLK-CCDV)$ Hold time, CCD valid after PCLK edge	2		ns
23	$t_{su}(CWEV-PCLK)$ Setup time, C_WE valid before PCLK edge	3		ns
24	$t_h(PCLK-CWEV)$ Hold time, C_WE valid after PCLK edge	2		ns

(1) The VPFE may be configured to operate in either positive or negative edge clocking mode. When in positive edge clocking mode the rising edge of PCLK is referenced. When in negative edge clocking mode the falling edge of PCLK is referenced.

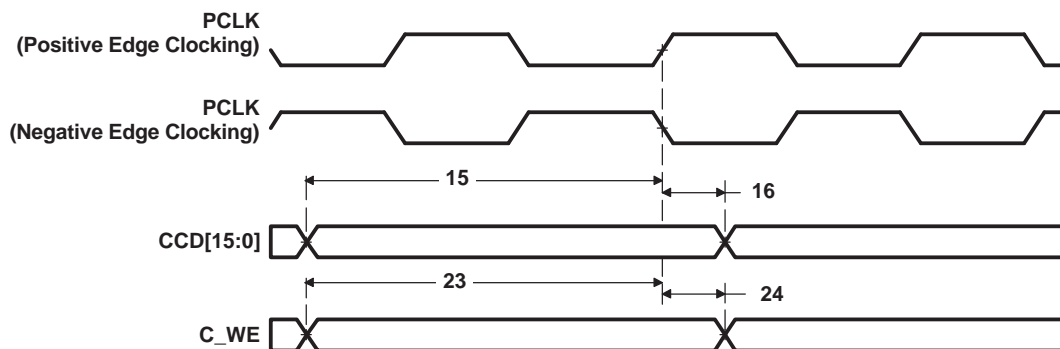
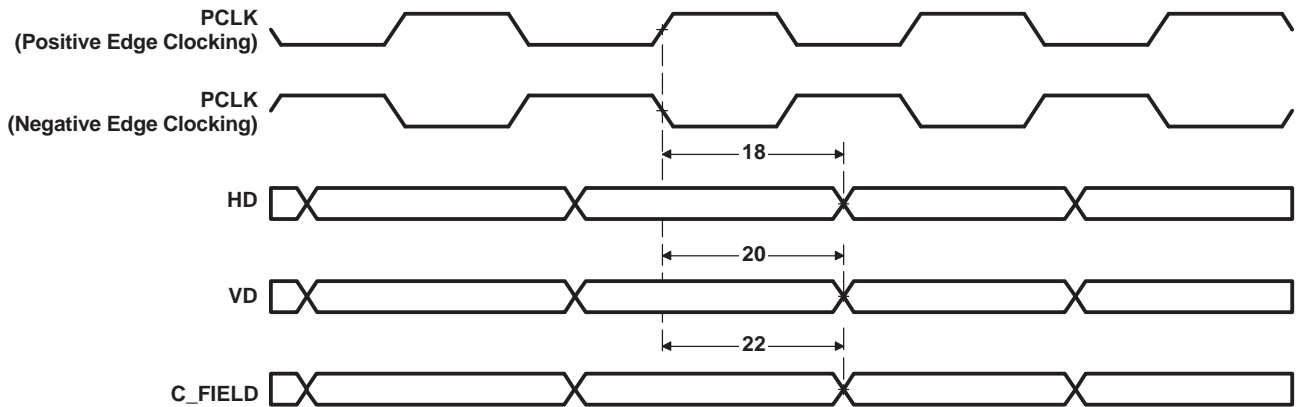

Figure 6-48. VPFE (CCD) Master Mode Input Data Timing

**Table 6-56. Switching Characteristics Over Recommended Operating Conditions for VPFE (CCD) Master Mode<sup>(1)</sup> (see Figure 6-49)**

NO.	PARAMETER	MIN	MAX	UNIT
18	$t_{d(PCLK-HDV)}$ Delay time, PCLK edge to HD valid	0.5	8	ns
20	$t_{d(PCLK-VDV)}$ Delay time, PCLK edge to VD valid	0.5	8	ns
22	$t_{d(PCLK-C\_FIELDV)}$ Delay time, PCLK edge to C_FIELD valid	0.5	8.3	ns

(1) The VPFE may be configured to operate in either positive or negative edge clocking mode. When in positive edge clocking mode the rising edge of PCLK is referenced. When in negative edge clocking mode the falling edge of PCLK is referenced.



**Figure 6-49. VPFE (CCD) Master Mode Control Output Data Timing**

### 6.13.2 Video Processing Back-End (VPBE)

The Video Processing Back-End (VPBE) consists of the On-Screen Display (OSD) module, the Video Encoder (VENC) including the Digital LCD (DLCD) and Analog (i.e., DAC) interfaces. The video encoder generates analog video output. The DLCD controller generates digital RGB/YCbCr data output and timing signals.

The VPBE register memory mapping is shown in Table 6-57.

**Table 6-57. VPBE Register Descriptions**

Address	Register	Description
0x01C7 2780	PID	Peripheral Revision and Class Information Register
0x01C7 2784	PCR	Peripheral Control Register

#### 6.13.2.1 On-Screen Display (OSD)

The major function of the OSD module is to gather and blend video data and display/bitmap data before feeding it to the Video Encoder (VENC) in YCbCr format. The video and display data is read from an external memory, typically DDR2. The OSD is programmed via control and parameter registers. The following are the primary features that are supported by the OSD.

- Simultaneous display of two video windows and two OSD windows (VIDWIN0/VIDWIN1 and OSDWIN0/OSDWIN1).
  - Separate enable for each window
  - Programmable width, height, and base starting coordinates for each window
  - External memory address and offset registers for each window
  - Support for x2 and x4 zoom in both the horizontal and vertical direction
  - OSDWIN1 can be used as an attribute window for OSDWIN0
  - Attribute window blinking intervals
  - Field/frame mode for the windows (interlaced/progressive)

- Eight step blending process between the OSD and video windows
- Transparency support for the OSD and video data (when a bitmap pixel is zero, there will be no blending for that corresponding video pixel)
- Resize from VGA to NTSC/PAL (640x480 to 720x576) for both the OSD and video windows
- Reads in YCbCr data in 4:2:2 format from external memory, with the capability for swapping the order of the CbCr component in the 32-bit word (this is relevant to the two video windows)
- Support for a ping-pong buffer scheme that can be used for VIDWIN0 (allows for video data to be accessed from two different locations in DDR2)
- Each OSD window (either one, but not both at the same time) is capable of reading in RGB data (16-bit data with six bits for the green and five bits each for the red and blue colors) instead of bitmap data in YCbCr format restricted to a maximum of 8-bits
- The OSD bitmap data width is selectable between 1, 2, 4, or 8-bits.
- Each OSD window supports 16 entries for the bitmap (to index into a 256 entry RAM/ROM CLUT table).
- Indirect support for 24-bit RGB input data (which will be transformed into 16-bit YCbCr video window data) via the wrapper interface in the VPBE.
- Support for a rectangular cursor window and a programmable background color selection.
  - Programmable color palette with the ability to select between a RAM/ROM table with support for 256 colors.
  - The width, height, and color of the cursor is programmable.
  - The display priority is: Rectangular-Cursor > OSDWIN1 > OSDWIN0 > VIDWIN1 > VIDWIN0 > background color
- Support for attenuation of the YCbCr values for the REC601 standard.

The following restrictions exist in the OSD module.

- Both the OSD windows and VIDWIN1 should be fully contained inside VIDWIN0.
- When one of the OSD windows is set in RGB mode, it cannot overlap with VIDWIN1.
- The OSD cannot support more than 256 color entries in the CLUT RAM/ROM. Some applications require higher number of entries, and one workaround is to use VIDWIN1 as an overlay mimicking the OSD window. Another option is to use the RGB mode for one of the OSD windows which allows for a total of 16-bits for the R, G, and B colors (64K colors).
- The OSD can only read YCbCr in 4:2:2 interleaved format for the video windows. Other formats, either color separate storage or 4:4:4/4:2:0 interleaved data is not supported.
- If the vertical resize filter is enabled for either of the video windows, the maximum horizontal window dimension cannot be greater than 720 currently.
- It is not possible to use both of the CLUT ROMs at the same time. However, one window can use RAM while another uses ROM.
- The 24-bit RGB input mode is only valid for one of the two video windows (programmable) and does not apply to the OSD windows.

The OSD register memory mapping is shown in [Table 6-58](#).

**Table 6-58. OSD Register Descriptions**

Address	Register	Description
0x01C7 2600	MODE	OSD Mode Register
0x01C7 2604	VIDWINMD	Video Window Mode Setup
0x01C7 2608	OSDWIN0MD	OSD Window Mode Setup
0x01C7 260C	OSDWIN1MD	OSD Window 1 Mode Setup (when used as a second OSD window)
0x01C7 260C	OSDATRMD	OSD Attribute Window Mode Setup (when used as an attribute window)
0x01C7 2610	RECTCUR	Rectangular Cursor Setup



**Table 6-58. OSD Register Descriptions (continued)**

0x01C7 2614	RSV0	Reserved
0x01C7 2618	VIDWIN0OFST	Video Window 0 Offset
0x01C7 261C	VIDWIN1OFST	Video Window 1 Offset
0x01C7 2620	OSDWIN0OFST	OSD Window 0 Offset
0x01C7 2624	OSDWIN1OFST	OSD Window 1 Offset
0x01C7 2628	RSV1	Reserved
0x01C7 262C	VIDWIN0ADR	Video Window 0 Address
0x01C7 2630	VIDWIN1ADR	Video Window 1 Address
0x01C7 2634	RSV2	Reserved
0x01C7 2638	OSDWIN0ADR	OSD Window 0 Address
0x01C7 263C	OSDWIN1ADR	OSD Window 1 Address
0x01C7 2640	BASEPX	Base Pixel X
0x01C7 2644	BASEPY	Base Pixel Y
0x01C7 2648	VIDWIN0XP	Video Window 0 X-Position
0x01C7 264C	VIDWIN0YP	Video Window 0 Y-Position
0x01C7 2650	VIDWIN0XL	Video Window 0 X-Size
0x01C7 2654	VIDWIN0YL	Video Window 0 Y-Size
0x01C7 2658	VIDWIN1XP	Video Window 1 X-Position
0x01C7 265C	VIDWIN1YP	Video Window 1 Y-Position
0x01C7 2660	VIDWIN1XL	Video Window 1 X-Size
0x01C7 2664	VIDWIN1YL	Video Window 1 Y-Size
0x01C7 2668	OSDWIN0XP	OSD Bitmap Window 0 X-Position
0x01C7 266C	OSDWIN0YP	OSD Bitmap Window 0 Y-Position
0x01C7 2670	OSDWIN0XL	OSD Bitmap Window 0 X-Size
0x01C7 2674	OSDWIN0YL	OSD Bitmap Window 0 Y-Size
0x01C7 2678	OSDWIN1XP	OSD Bitmap Window 1 X-Position
0x01C7 267C	OSDWIN1YP	OSD Bitmap Window 1 Y-Position
0x01C7 2680	OSDWIN1XL	OSD Bitmap Window 1 X-Size
0x01C7 2684	OSDWIN1YL	OSD Bitmap Window 1 Y-Size
0x01C7 2688	CURXP	Rectangular Cursor Window X-Position
0x01C7 268C	CURYYP	Rectangular Cursor Window Y-Position
0x01C7 2690	CURXL	Rectangular Cursor Window X-Size
0x01C7 2694	CURYL	Rectangular Cursor Window Y-Size
0x01C7 2698	RSV3	Reserved
0x01C7 269C	RSV4	Reserved
0x01C7 26A0	W0BMP01	Window 0 Bitmap Value to Palette Map 0/1
0x01C7 26A4	W0BMP23	Window 0 Bitmap Value to Palette Map 2/3
0x01C7 26A8	W0BMP45	Window 0 Bitmap Value to Palette Map 4/5
0x01C7 26AC	W0BMP67	Window 0 Bitmap Value to Palette Map 6/7
0x01C7 26B0	W0BMP89	Window 0 Bitmap Value to Palette Map 8/9
0x01C7 26B4	W0BMPAB	Window 0 Bitmap Value to Palette Map A/B
0x01C7 26B8	W0BMPCD	Window 0 Bitmap Value to Palette Map C/D
0x01C7 26BC	W0BMPEF	Window 0 Bitmap Value to Palette Map E/F
0x01C7 26C0	W1BMP01	Window 1 Bitmap Value to Palette Map 0/1
0x01C7 26C4	W1BMP23	Window 1 Bitmap Value to Palette Map 2/3
0x01C7 26C8	W1BMP45	Window 1 Bitmap Value to Palette Map 4/5
0x01C7 26CC	W1BMP67	Window 1 Bitmap Value to Palette Map 6/7
0x01C7 26D0	W1BMP89	Window 1 Bitmap Value to Palette Map 8/9

**Table 6-58. OSD Register Descriptions (continued)**

0x01C7 26D4	W1BMPAB	Window 1 Bitmap Value to Palette Map A/B
0x01C7 26D8	W1BMPCD	Window 1 Bitmap Value to Palette Map C/D
0x01C7 26DC	W1BMPEF	Window 1 Bitmap Value to Palette Map E/F
0x01C7 26E0	-	Reserved
0x01C7 26E4	RSV5	Reserved
0x01C7 26E8	MISCCTL	Miscellaneous Control
0x01C7 26EC	CLUTRAMYCB	CLUT RAMYCB Setup
0x01C7 26F0	CLUTRAMCR	CLUT RAM Setup
0x01C7 26F4	TRANSPVAL	CLUT RAM Setup
0x01C7 26F8	RSV6	Reserved
0x01C7 26FC	PPVWIN0ADR	Ping-Pong Video Window 0 Address

### 6.13.2.2 Video Encoder (VENC)

Analog/DACs interface of the Video Encoder (VENC) supports the following features.

- Master Clock Input - 27MHz (x2 Upsampling)
- SDTV Support
  - Composite NTSC-M, PAL-B/D/G/H/I
  - S-Video (Y/C)
  - Component YPbPr (SMPTE/EBU N10, Betacam, MII)
  - RGB
  - Non-Interlace
  - CGMS/WSS
  - Line 21 Closed Caption Data Encoding
  - Chroma Low Pass Filter 1.5MHz/3MHz
  - Programmable SC-H phase
- HDTV Support
  - Progressive Output (525p/625p)
  - Component YPbPr
  - RGB
  - CGMS/WSS
- 4 10-bit Over-Sampling D/A Converters
- Optional 7.5% Pedestal
- 16-235/0-255 Input Amplitude Selectable
- Programmable Luma Delay
- Master/Slave Operation
- Internal Color Bar Generation (100%/75%)

The Digital LCD Controller (DLCD) of the VENC supports the following features.

- Programmable DCLK
- Various Output Formats
  - YCbCr 16bit
  - YCbCr 8bit
  - ITU-R BT. 656
  - Parallel RGB 24bit
- Low Pass Filter for Digital RGB Output
- Programmable Timing Generator
- Master/Slave Operation

- Internal Color Bar Generation (100%/75%)

The VENC register memory mapping including the Digital LCD and DACs is shown in [Table 6-59](#).

**Table 6-59. VENC (Including Digital LCD and DACs) Register Descriptions**

Address	Register	Description
0x01C7 2400	VMOD	Video Mode
0x01C7 2404	VIDCTL	Video Interface I/O Control
0x01C7 2408	VDPRO	Video Data Processing
0x01C7 240C	SYNCCTL	Sync Control
0x01C7 2410	HSPLS	Horizontal Sync Pulse Width
0x01C7 2414	VSPLS	Vertical Sync Pulse Width
0x01C7 2418	HINT	Horizontal Interval
0x01C7 241C	HSTART	Horizontal Valid Data Start Position
0x01C7 2420	HVALID	Horizontal Data Valid Range
0x01C7 2424	VINT	Vertical Interval
0x01C7 2428	VSTART	Vertical Valid Data Start Position
0x01C7 242C	VVALID	Vertical Data Valid Range
0x01C7 2430	HSDLY	Horizontal Sync Delay
0x01C7 2434	VSDLY	Vertical Sync Delay
0x01C7 2438	YCCTL	YCbCr Control
0x01C7 243C	RGBCTL	RGB Control
0x01C7 2440	RGBCLP	RGB Level Clipping
0x01C7 2444	LINECTL	Line ID Control
0x01C7 2448	CULLLINE	Culling Line Control
0x01C7 244C	LCDOUT	LCD Output Signal Control
0x01C7 2450	BRTS	Brightness Start Position Signal Control
0x01C7 2454	BRTW	Brightness Width Signal Control
0x01C7 2458	ACCTL	LCD_AC Signal Control
0x01C7 245C	PWMP	PWM Start Position Signal Control
0x01C7 2460	PWMW	PWM Width Signal Control
0x01C7 2464	DCLKCTL	DCLK Control
0x01C7 2468	DCLKPTN0	DCLK Pattern 0
0x01C7 246C	DCLKPTN1	DCLK Pattern 1
0x01C7 2470	DCLKPTN2	DCLK Pattern 2
0x01C7 2474	DCLKPTN3	DCLK Pattern 3
0x01C7 2478	DCLKPTN0A	DCLK Auxiliary Pattern 0
0x01C7 247C	DCLKPTN1A	DCLK Auxiliary Pattern 1
0x01C7 2480	DCLKPTN2A	DCLK Auxiliary Pattern 2
0x01C7 2484	DCLKPTN3A	DCLK Auxiliary Pattern 3
0x01C7 2488	DCLKHS	Horizontal DCLK Mask Start
0x01C7 248C	DCLKHSA	Horizontal Auxiliary DCLK Mask Start
0x01C7 2490	DCLKHR	Horizontal DCLK Mask Range
0x01C7 2494	DCLKVS	Vertical DCLK Mask Start
0x01C7 2498	DCLKVR	Vertical DCLK Mask Range
0x01C7 249C	CAPCTL	Caption Control
0x01C7 24A0	CAPDO	Caption Data Odd Field
0x01C7 24A4	CAPDE	Caption Data Even Field
0x01C7 24A8	ATR0	Video Attribute Data # 0
0x01C7 24AC	ATR1	Video Attribute Data # 1

**Table 6-59. VENC (Including Digital LCD and DACs) Register Descriptions (continued)**

0x01C7 24B0	ATR2	Video Attribute Data # 2
0x01C7 24B4		Reserved
0x01C7 24B4		
0x01C7 24B4		
0x01C7 24B4		
0x01C7 24B8	VSTAT	Video Status
0x01C7 24BC		Reserved
0x01C7 24C0		
0x01C7 24C4	DACTST	DAC Test
0x01C7 24C8	YCOLVL	YOUT and COUT Levels
0x01C7 24CC	SCPROG	Sub-Carrier Programming
0x01C7 24D0		Reserved
0x01C7 24D4		
0x01C7 24D8		
0x01C7 24DC	CVBS	Composite Mode
0x01C7 24E0	CMPNT	Component Mode
0x01C7 24E4	ETMG0	CVBS Timing Control 0
0x01C7 24E8	ETMG1	CVBS Timing Control 1
0x01C7 24EC	ETMG2	Component Timing Control 0
0x01C7 24F0	ETMG3	Component Timing Control 1
0x01C7 24F4	DACSEL	DAC Output Select
0x01C7 24F8		Reserved
0x01C7 24FC		
0x01C7 2500	ARGBX0	Analog RGB Matrix 0
0x01C7 2504	ARGBX1	Analog RGB Matrix 1
0x01C7 2508	ARGBX2	Analog RGB Matrix 2
0x01C7 250C	ARGBX3	Analog RGB Matrix 3
0x01C7 2510	ARGBX4	Analog RGB Matrix 4
0x01C7 2514	DRGBX0	Digital RGB Matrix 0
0x01C7 2518	DRGBX1	Digital RGB Matrix 1
0x01C7 251C	DRGBX2	Digital RGB Matrix 2
0x01C7 2520	DRGBX3	Digital RGB Matrix 3
0x01C7 2524	DRGBX4	Digital RGB Matrix 4
0x01C7 2528	VSTARTA	Vertical Data Valid Start Position for Even Field
0x01C7 252C	OSDCLK0	OSD Clock Control 0
0x01C7 2530	OSDCLK1	OSD Clock Control 1
0x01C7 2534	HVLDCL0	Horizontal Valid Culling Control 0
0x01C7 2538	HVLDCL1	Horizontal Valid Culling Control 1
0x01C7 253C	OSDHADV	OSD Horizontal Sync Advance

6.13.2.3 VPBE Electrical Data/Timing

Table 6-60. Timing Requirements for VPBE CLK Inputs (see Figure 6-50)

NO.			MIN	MAX	UNIT
1	$t_c(\text{PCLK})$	Cycle time, PCLK	13.33	160	ns
2	$t_w(\text{PCLKH})$	Pulse duration, PCLK high	5.7		ns
3	$t_w(\text{PCLKL})$	Pulse duration, PCLK low	5.7		ns
4	$t_t(\text{PCLK})$	Transition time, PCLK		3	ns
5	$t_c(\text{VPBECLK})$	Cycle time, VPBECLK	13.33	160	ns
6	$t_w(\text{VPBECLKH})$	Pulse duration, VPBECLK high	5.7		ns
7	$t_w(\text{VPBECLKL})$	Pulse duration, VPBECLK low	5.7		ns
8	$t_t(\text{VPBECLK})$	Transition time, VPBECLK		3	ns

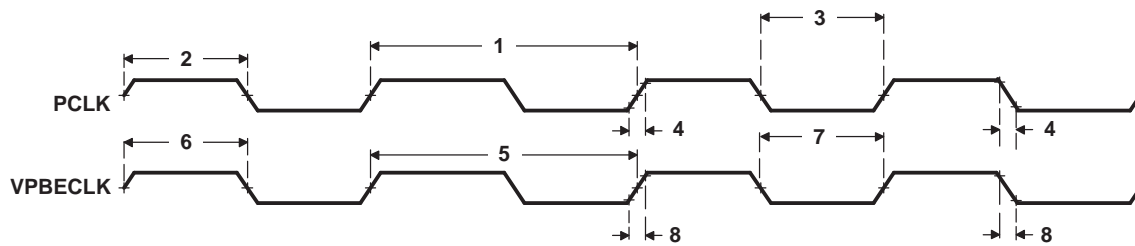
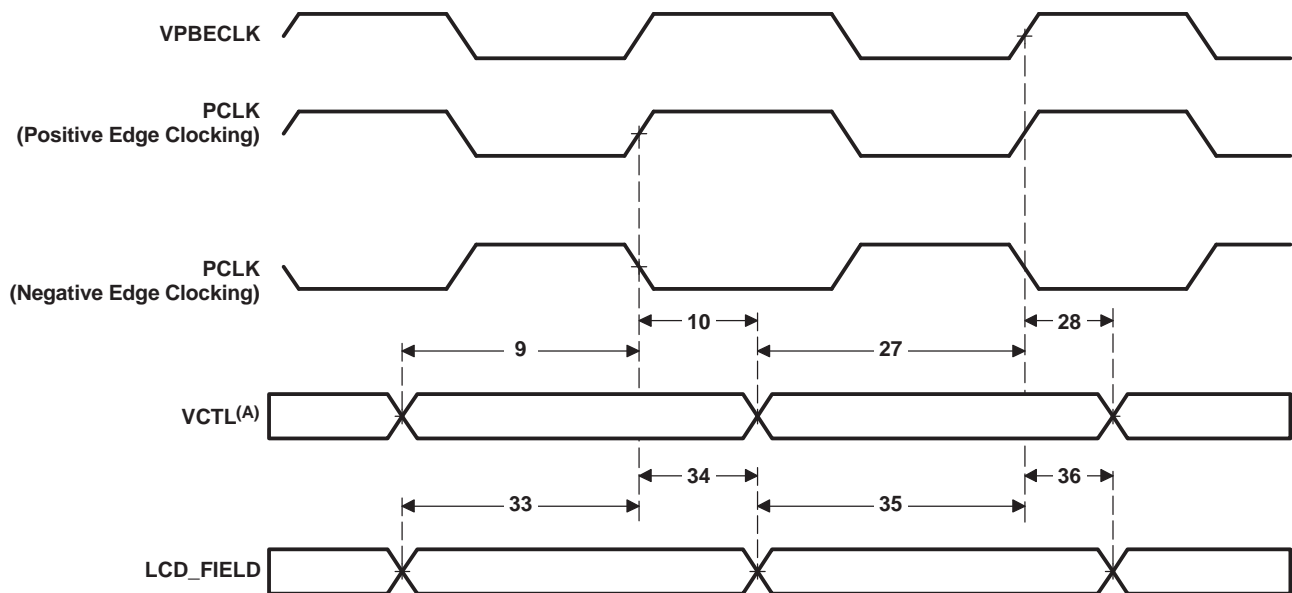

Figure 6-50. VPBE PCLK and VPBECLK Timing

**Table 6-61. Timing Requirements for VPBE Control Input With Respect to PCLK and VPBECLK<sup>(1)</sup> (see Figure 6-51)**

NO.		MIN	MAX	UNIT
9	$t_{su}(VCTLV-PCLK)$ Setup time, VCTL valid before PCLK edge	2		ns
10	$t_h(PCLK-VCTLV)$ Hold time, VCTL valid after PCLK edge	0.5		ns
27	$t_{su}(VCTLV-VPBECLK)$ Setup time, VCTL valid before VPBECLK rising edge	2		ns
28	$t_h(VPBECLK-VCTLV)$ Hold time, VCTL valid after VPBECLK rising edge	0.5		ns
33	$t_{su}(FIELD-PCLK)$ Setup time, LCD_FIELD valid before PCLK edge	5P <sup>(2)</sup>		ns
34	$t_h(PCLK-FIELD)$ Hold time, LCD_FIELD valid after PCLK edge	5P <sup>(2)</sup>		ns
35	$t_{su}(FIELD-VPBECLK)$ Setup time, LCD_FIELD valid before VPBECLK edge	5P <sup>(2)</sup>		ns
36	$t_h(VPBECLK-FIELD)$ Hold time, LCD_FIELD valid after VPBECLK edge	5P <sup>(2)</sup>		ns

- (1) PCLK may be configured to operate in either positive or negative edge clocking mode. When in positive edge clocking mode, the rising edge of PCLK is referenced. When in negative edge clocking mode, the falling edge of PCLK is referenced.  
 (2) P = 1/(VCLKIN clock frequency) in ns. VCLKIN is either PCLK or VPBECLK, whichever is used.



A. VCTL = HSYNC and VSYNC

**Figure 6-51. VPBE Input Timing With Respect to PCLK and VPBECLK**

**Table 6-62. Switching Characteristics Over Recommended Operating Conditions for VPBE Control and Data Output With Respect to PCLK and VPBECLK<sup>(1)</sup> (see Figure 6-52)**

NO.	PARAMETER	MIN	MAX	UNIT
11	$t_{d(PCLK-VCTLV)}$ Delay time, PCLK edge to VCTL valid		13.3	ns
12	$t_{d(PCLK-VCTLIV)}$ Delay time, PCLK edge to VCTL invalid	2		ns
13	$t_{d(PCLK-VDATAV)}$ Delay time, PCLK edge to VDATA valid		13.6	ns
14	$t_{d(PCLK-VDATAIV)}$ Delay time, PCLK edge to VDATA invalid	2		ns
29	$t_{d(VPBECLK-VCTLV)}$ Delay time, VPBECLK rising edge to VCTL valid		13.3	ns
30	$t_{d(VPBECLK-VCTLIV)}$ Delay time, VPBECLK rising edge to VCTL invalid	2		ns
31	$t_{d(VPBECLK-VDATAV)}$ Delay time, VPBECLK rising edge to VDATA valid		13.6	ns
32	$t_{d(VPBECLK-VDATAIV)}$ Delay time, VPBECLK rising edge to VDATA invalid	2		ns

(1) PCLK may be configured to operate in either positive or negative edge clocking mode. When in positive edge clocking mode, the rising edge of PCLK is referenced. When in negative edge clocking mode, the falling edge of PCLK is referenced.

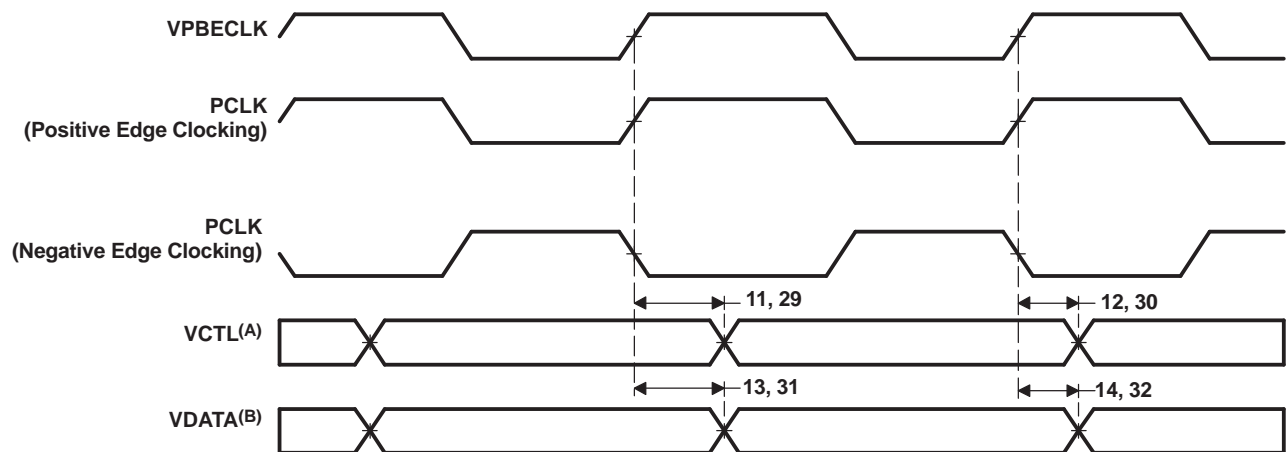

- A. VCTL = HSYNC, VSYNC, LCD\_FIELD, and LCD\_OE
- B. VDATA = COUT[7:0], YOUT[7:0], R[7:0], G[7:0], and B[7:0]

**Figure 6-52. VPBE Output Timing With Respect to PCLK and VPBECLK**

**Table 6-63. Switching Characteristics Over Recommended Operating Conditions for VPBE Control and Data Output With Respect to VCLK<sup>(1)(2)</sup> (see Figure 6-53)**

NO.	PARAMETER	MODE <sup>(3)</sup>	MIN	MAX	UNIT
17	$t_c(\text{VCLK})$ Cycle time, VCLK		13.33	160	ns
18	$t_w(\text{VCLKH})$ Pulse duration, VCLK high (positive-edge clocking)		H - 1.3 <sup>(4)</sup>	H - 0.3 <sup>(4)</sup>	ns
	Pulse duration, VCLK high (negative-edge clocking)		L - 1.3 <sup>(4)</sup>	L - 0.3 <sup>(4)</sup>	ns
19	$t_w(\text{VCLKL})$ Pulse duration, VCLK low (positive-edge clocking)		L + 0.3 <sup>(4)</sup>	L + 1.3 <sup>(4)</sup>	ns
	Pulse duration, VCLK low (negative-edge clocking)		H + 0.3 <sup>(4)</sup>	H + 1.3 <sup>(4)</sup>	ns
20	$t_t(\text{VCLK})$ Transition time, VCLK			3	ns
21	$t_d(\text{VCLKINH-VCLKH})$ Delay time, VCLKIN high to VCLK high		2	12	ns
22	$t_d(\text{VCLKINL-VCLKL})$ Delay time, VCLKIN low to VCTL low		2	12	ns
23	$t_d(\text{VCLK-VCTLV})$ Delay time, VCLK negative edge to VCTL valid			7.5	ns
	Delay time, VCLK positive edge to VCTL valid			6.9	ns
24	$t_d(\text{VCLKL-VCTLIV})$ Delay time, VCLK negative edge to VCTL invalid		2		ns
	Delay time, VCLK positive edge to VCTL invalid		1.5		ns
25	$t_d(\text{VCLK-VDATAV})$ Delay time, VCLK negative edge to VDATA valid			6.8	ns
	Delay time, VCLK positive edge to VDATA valid			6.3	ns
26	$t_d(\text{VCLKL-VDATAIV})$ Delay time, VCLK negative edge to VDATA invalid	RGB	2.1		ns
		YCC	2.5		ns
	Delay time, VCLK positive edge to VDATA invalid	RGB	1.9		ns
		YCC	2.1		ns

- (1) The VPBE may be configured to operate in either positive or negative edge clocking mode. When in positive edge clocking mode, the rising edge of VCLK is referenced. When in negative edge clocking mode, the falling edge of VCLK is referenced.
- (2) VCLKIN = PCLK or VPBECLK
- (3) RGB and YCC modes utilize different data pins. RGB mode uses data pins: R[7:0], G[7:0], and B[7:0]. YCC mode uses data pins: COUT[7:0] and YOUT[7:0].
- (4) H and L are the high and low pulse widths of the input clock to the VPBE, respectively. For example, if VPBECLK is used as the input clock and it has a high pulse duration of 6.67 ns, the resulting high pulse duration of VCLK, if positive-edge clocking is selected, will be a MAX of 6.37 ns and a MIN of 5.27 ns.

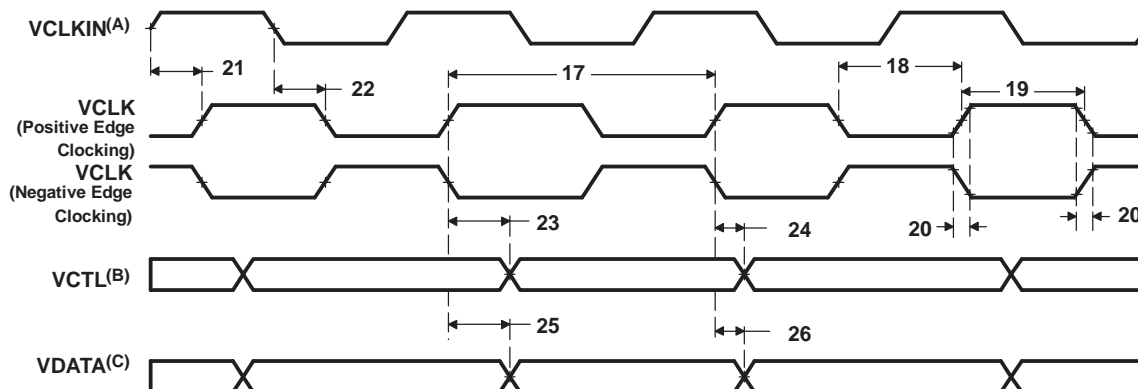

- A. VCLKIN = PCLK or VPBECLK
- B. VCTL = HSYNC, VSYNC, LCD\_FIELD, and LCD\_OE
- C. VDATA = COUT[7:0], YOUT[7:0], R[7:0], G[7:0], and B[7:0]

**Figure 6-53. VPBE Control and Data Output Timing With Respect to VCLK**



### 6.13.2.4 DAC Electrical Data/Timing

**Table 6-64. Switching Characteristics Over Recommended Operating Conditions for DAC Static Specifications**

NO.	PARAMETER	TEST CONDITIONS	MIN	TYP	MAX	UNIT
	<b>DC Accuracy</b> Integral Non-Linearity (INL) Differential Non-Linearity (DNL)		-1.0 -0.5		1.0 0.5	LSB LSB
	<b>Analog Output</b> Offset Error Gain Error Full-Scale Output Voltage	$R_{LOAD} = 500 \Omega$		0.5 5 500		LSB %F <sub>S</sub> mV <sub>PP</sub>
	Output Capacitance			200		pF
	<b>Reference</b> Reference Voltage Range ( $V_{REF}$ ) Full-Scale Current Adjust Resistor (RBIAS)		0.475 3.8	0.5 4.0	0.525 4.2	V k $\Omega$

**Table 6-65. Switching Characteristics Over Recommended Operating Conditions for DAC Dynamic Specifications**

NO.	PARAMETER	TEST CONDITIONS	MIN	TYP	MAX	UNIT
	Output Update Rate ( $F_{CLK}$ )			27	60	MHz
	Signal Bandwidth			6		MHz
	SFDR to Nyquist	$F_{CLK} = 27 \text{ MHz}$		60		dB
		$F_{OUT} = 2.0 \text{ MHz}$				
		$F_{CLK} = 60 \text{ MHz}$		60		dB
		$F_{OUT} = 2.0 \text{ MHz}$				
	SFDR within Bandwidth	$F_{CLK} = 27 \text{ MHz}$		60		dB
		$F_{OUT} = 2.0 \text{ MHz}$				
		$F_{CLK} = 60 \text{ MHz}$		60		dB
		$F_{OUT} = 2.0 \text{ MHz}$				
	PSRR Over Temp vs Power Supply		50			dB

The DM6446's analog video DAC outputs are designed to drive a 500- $\Omega$  load. [Figure 6-54](#) describes a typical circuit that will permit connecting the analog video output from the DM6446 device to standard 75- $\Omega$  impedance video systems. Another solution is to use a Video Amplifier, such as the Texas Instruments' OPA361, which provides a complete solution to the typical output circuit shown in [Figure 6-54](#).

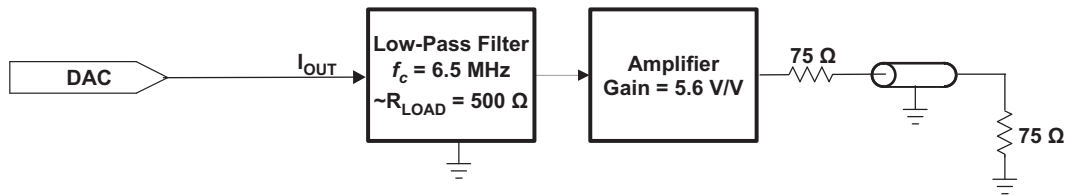

Figure 6-54. Typical Output Circuit for NTSC/PAL Video From DACs

### 6.14 Host-Port Interface (HPI)

The Host Port Interface (HPI) provides a parallel port through which an external host processor can access the DM6446 memory space. The host device is asynchronous to the DM6446 clocks and functions as a master to the HPI interface. The HPI enables a host device and DM6446 to exchange information via internal or external memory. Both the host and DM6446 can access the HPI control register (HPIC) and the HPI address registers (HPIAR, HPIAW). The host can access the HPI data register (HPID) and the HPIC by using the external data and interface control signals.

The HPI interface shares the DaVinci EMIFA 16-bit data bus pins for multiplexed address/data and supports the following modes:

- 16 Bit Multiplexed mode / dual half-word cycles (16 bit host data bus/32 bit memory width)
- ARM ROM supports booting of DM6446 ARM processor from an external processor

The HPI registers are summarized in [Table 6-66](#). For more detailed information on the HPI peripheral, see the *Documentation Support* section for the Host Port Interface (HPI) Reference Guide.

**Table 6-66. Host-Port Interface (HPI) Register Descriptions**

HEX ADDRESS RANGE	ACRONYM	REGISTER NAME
0x01C4 0030	HPI_CTL	Host-Port Interface Configuration Register
0x01C6 7800	HPI_PID	
0x01C6 7804	HPIPWREMU	HPI Power and Emulation Management Register
0x01C6 7808 - 0x01C6 782F	–	Reserved
0x01C6 7830	HPIC	Host-Port Interface Control Register
0x01C6 7834	HPIAW	Host-Port Interface Write Address Register
0x01C6 7838	HPIAR	Host-Port Interface Read Address Register
0x01C6 783C - 0x01C6 7FFF	–	Reserved

The HPI\_CTL register sets the owner of HPIA(R/W) and HPIC registers for HPI address and control. The details for HPI\_CTL are shown in [Figure 6-55](#) and [Table 6-67](#).

**Figure 6-55. HPI\_CTL Register**

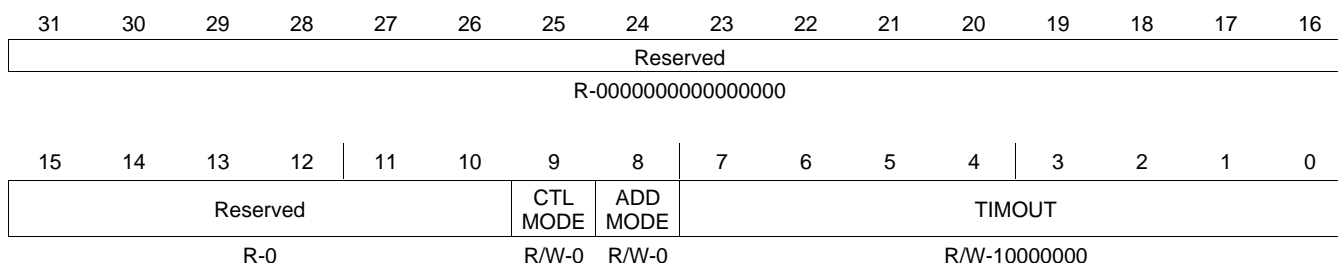

LEGEND: R = Read, W = Write, n = value at reset

**Table 6-67. HPI\_CTL Register Description**

Name	Description
CTLMODE	HPIC register write access 0 = External Host 1 = DM6446 (if ADDMODE = 1)
ADDMODE	HPIA register write access 0 = External Host 1 = DM6446
TIMOUT	Host burst write timeout value

### 6.14.1 Host-Port Interface (HPI) Electrical Data/Timing

**Table 6-68. Timing Requirements for Host-Port Interface Cycles<sup>(1)(2)</sup>** (see Figure 6-56 through Figure 6-57)

NO.			MIN	MAX	UNIT
1	$t_{su}(SELV-HSTBL)$	Setup time, select signals <sup>(3)</sup> valid before $\overline{HSTROBE}$ low	5		ns
2	$t_h(HSTBL-SELV)$	Hold time, select signals <sup>(3)</sup> valid after $\overline{HSTROBE}$ low	2		ns
3	$t_w(HSTBL)$	Pulse duration, $\overline{HSTROBE}$ low	15		ns
4	$t_w(HSTBH)$	Pulse duration, $\overline{HSTROBE}$ high between consecutive accesses	2P		ns
12	$t_{su}(HDV-HSTBH)$	Setup time, host data valid before $\overline{HSTROBE}$ high	5		ns
13	$t_h(HSTBH-HDV)$	Hold time, host data valid after $\overline{HSTROBE}$ high	0		ns
14	$t_h(HRDYL-HSTBH)$	Hold time, $\overline{HSTROBE}$ high after $\overline{HRDY}$ low. $\overline{HSTROBE}$ should not be inactivated until $\overline{HRDY}$ is active (low); otherwise, HPI writes will not complete properly.	2		ns

(1)  $\overline{HSTROBE}$  refers to the following logical operation on  $\overline{HCS}$ ,  $\overline{HDS1}$ , and  $\overline{HDS2}$ :  $[\text{NOT}(\overline{HDS1} \text{ XOR } \overline{HDS2})] \text{ OR } \overline{HCS}$ .

(2) P = 1/CPU clock frequency in ns. For example, when running parts at 594 MHz, use P = 1.68 ns.

(3) Select signals include:  $\overline{HCNTL}[1:0]$  and  $\overline{HR/W}$ . For HPI16 mode only, select signals also include  $\overline{HHWIL}$ .

**Table 6-69. Switching Characteristics Over Recommended Operating Conditions During Host-Port Interface Cycles<sup>(1)</sup>** (see Figure 6-56 through Figure 6-57)

NO.	PARAMETER	MIN	MAX	UNIT
6	$t_d(HSTBL-HRDYH)$	0	12	ns
7	$t_d(HSTBL-HDLZ)$	0		ns
8	$t_d(HDV-HRDYL)$	0		ns
9	$t_{oh}(HSTBH-HDV)$	1.5		ns
15	$t_d(HSTBH-HDHZ)$		7	ns
16	$t_d(HSTBL-HDV)$		15	ns
20	$t_d(HCSL-HRDYH)$	0	12	ns

(1)  $\overline{HSTROBE}$  refers to the following logical operation on  $\overline{HCS}$ ,  $\overline{HDS1}$ , and  $\overline{HDS2}$ :  $[\text{NOT}(\overline{HDS1} \text{ XOR } \overline{HDS2})] \text{ OR } \overline{HCS}$ .

(2) This parameter is used during HPI16 reads and writes. For reads, at the beginning of the first half-word transfer (HPI16) on the falling edge of  $\overline{HSTROBE}$ , the HPI sends the request to the EDMA internal address generation hardware, and  $\overline{HRDY}$  remains high until the EDMA internal address generation hardware loads the requested data into HPI16. For writes,  $\overline{HRDY}$  goes high if the internal write buffer is full.

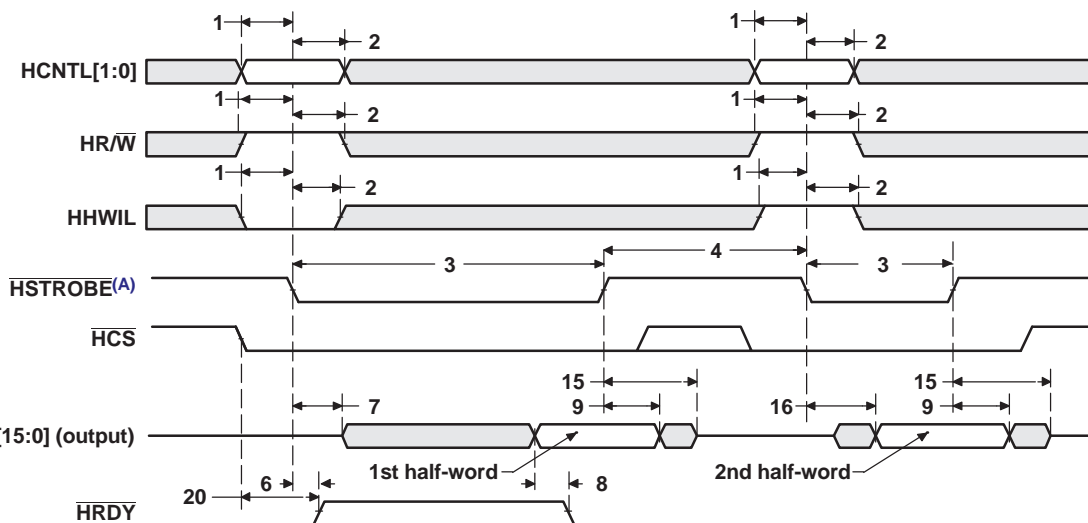

A.  $\overline{HSTROBE}$  refers to the following logical operation on  $\overline{HCS}$ ,  $\overline{HDS1}$ , and  $\overline{HDS2}$ :  $[\text{NOT}(\overline{HDS1} \text{ XOR } \overline{HDS2})] \text{ OR } \overline{HCS}$ .

**Figure 6-56. HPI16 Read Timing**

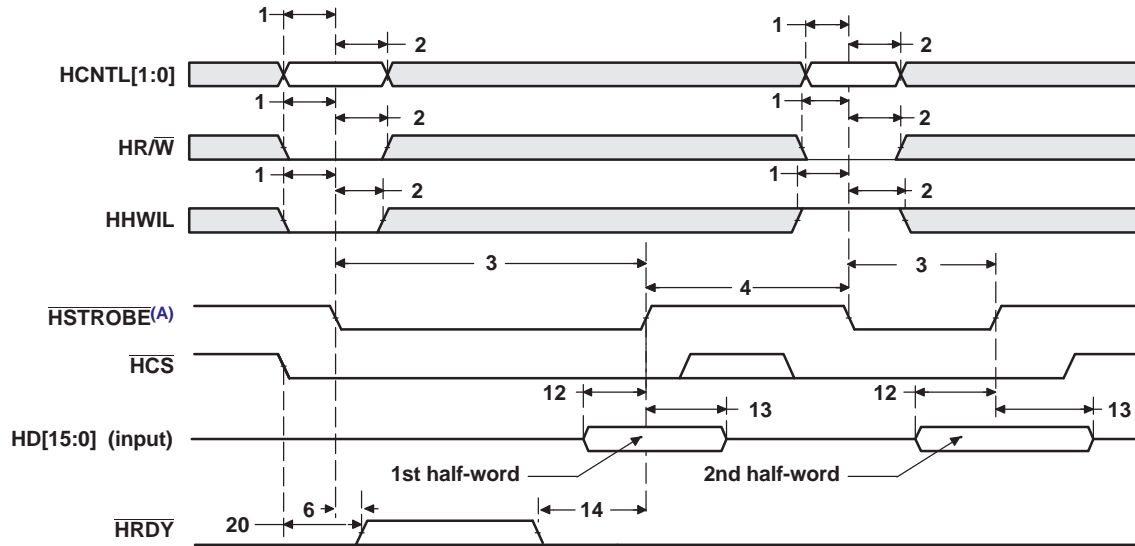

- A.  $\overline{\text{HSTROBE}}$  refers to the following logical operation on  $\overline{\text{HCS}}$ ,  $\overline{\text{HDS1}}$ , and  $\overline{\text{HDS2}}$ :  $[\text{NOT}(\overline{\text{HDS1}} \text{ XOR } \overline{\text{HDS2}})] \text{ OR } \overline{\text{HCS}}$ .

**Figure 6-57. HPI16 Write Timing**

## 6.15 USB 2.0

The DM6446 USB2.0 peripheral supports the following features:

- USB 2.0 peripheral at speeds high speed (HS: 480 Mb/s) and full speed (FS: 12 Mb/s)
- USB 2.0 host at speeds HS, FS, and low speed (LS: 1.5 Mb/s)
- All transfer modes (control, bulk, interrupt, and isochronous)
- 4 Transmit (TX) and 4 Receive (RX) endpoints in addition to endpoint 0
- FIFO RAM
  - 4K endpoint
  - Programmable size
- Connects to a standard UTMI+ PHY with a 60 MHz, 8-bit interface
- Connects to a standard Charge Pump for VBUS 5 V generation
- RNDIS mode for accelerating RNDIS type protocols using short packet termination over USB

### 6.15.1 USBPHY\_CTL Register Description

The USB physical interface control register USBPHY\_CTL is described in [Figure 6-58](#) and [Table 6-70](#).

**Figure 6-58. USBPHY\_CTL Register**

31	9	8	7	6	5	4	3	2	1	0
Reserved	PHYCLKGD	SESNDEN	VBDTCTEN	RSV	PHYPLLON	CLKO1SEL	OSCPDWN	RSV	PHYPDWN	
R-0000 0000 0000 0000 0000 000	R-0	R/W-1	R/W-1	R-0	R/W-0	R/W-0	R/W-1	R/W-1	R/W-1	

LEGEND: R = Read, W = Write, n = value at reset

**Table 6-70. USBPHY\_CTL Register Descriptions**

Name	Description
PHYCLKGD	USB PHY Power and Clock Good 0 = Phy power not ramped or PLL not locked 1 = Phy power is good and PLL is locked
SESNDEN	Session End Comparator enable 0 = comparator disabled 1 = comparator enabled
VBDTCTEN	vbus comparator enable 0 = comparators (except session end) disabled 1 = comparators (except session end) enabled
PHYPLLON	USB PHY PLL suspend override 0 = Normal PLL operation 1 = Override PLL suspend state
CLKO1SEL	CLK_OUT1 frequency select 0 = 24 MHz 1 = 12 MHz
OSCPDWN	USB PHY oscillator power down control 0 = PHY oscillator powered 1 = PHY oscillator power off
PHYPDWN	USB PHY power down control 0 = PHY powered 1 = PHY power off

## 6.15.2 USB2.0 Peripheral Register Description(s)

The USB register memory mapping is shown in [Table 6-71](#).

**Table 6-71. USB 2.0 Register Descriptions**

Address	Acronym	Register Description
0x01C6 4000	REVR	Revision Register
0x01C6 4004	CTRLR	Control Register
0x01C6 4008	STATR	Status Register
0x01C6 4010	RNDISR	RNDIS Register
0x01C6 4014	AUTOREQ	Auto Request Register
0x01C6 4020	INTSRCR	USB Interrupt Source Register
0x01C6 4024	INTSETR	USB Interrupt Source Set Register
0x01C6 4028	INTCLRR	USB Interrupt Source Clear Register
0x01C6 402C	INTMSKR	USB Interrupt Mask Register
0x01C6 4030	INTMSKSETR	USB Interrupt Mask Set Register
0x01C6 4034	INTMSKCLRR	USB Interrupt Mask Clear Register
0x01C6 4038	INTMASKEDR	USB Interrupt Source Masked Register
0x01C6 403C	EOIR	USB End of Interrupt Register
0x01C6 4040	INTVECTR	USB Interrupt Vector Register
0x01C6 4080	TCPPICR	TX CPPI Control Register
0x01C6 4084	TCPPITDR	TX CPPI Teardown Register
0x01C6 4088	TCPPIEOIR	TX CPPI DMA Controller End of Interrupt Register
0x01C6 408C	TCPPIIVECTR	TX CPPI DMA Controller Interrupt Vector Register
0x01C6 4090	TCPPIMSKSR	TX CPPI Masked Status Register
0x01C6 4094	TCPPIRAWSR	TX CPPI Raw Status Register
0x01C6 4098	TCPPIIENSETR	TX CPPI Interrupt Enable Set Register
0x01C6 409C	TCPPIIENCLRR	TX CPPI Interrupt Enable Clear Register
0x01C6 40C0	RCPPICR	RX CPPI Control Register
0x01C6 40D0	RCPPIMSKSR	RX CPPI Masked Status Register
0x01C6 40D4	RCPPIRAWSR	RX CPPI Raw Status Register
0x01C6 40D8	RCPPIIENSETR	RX CPPI Interrupt Enable Set Register
0x01C6 40DC	RCPPIIENCLRR	RX CPPI Interrupt Enable Clear Register
0x01C6 40E0	RBUFCNT0	RX Buffer Count 0 Register
0x01C6 40E4	RBUFCNT1	RX Buffer Count 1 Register
0x01C6 40E8	RBUFCNT2	RX Buffer Count 2 Register
0x01C6 40EC	RBUFCNT3	RX Buffer Count 3 Register
<b>TX/RX CCPI Channel 0 State Block</b>		
0x01C6 4100	TCPPIDMASTATEW0	TX CPPI DMA State Word 0
0x01C6 4104	TCPPIDMASTATEW1	TX CPPI DMA State Word 1
0x01C6 4108	TCPPIDMASTATEW2	TX CPPI DMA State Word 2
0x01C6 410C	TCPPIDMASTATEW3	TX CPPI DMA State Word 3
0x01C6 4110	TCPPIDMASTATEW4	TX CPPI DMA State Word 4
0x01C6 4114	TCPPIDMASTATEW5	TX CPPI DMA State Word 5
0x01C6 4118	TCPPIDMASTATEW6	TX CPPI DMA State Word 6
0x01C6 411C	TCPPICOMPTR	TX CPPI Completion Pointer
0x01C6 4120	RCPPIDMASTATEW0	RX CPPI DMA State Word 0
0x01C6 4124	RCPPIDMASTATEW1	RX CPPI DMA State Word 1
0x01C6 4128	RCPPIDMASTATEW2	RX CPPI DMA State Word 2

**Table 6-71. USB 2.0 Register Descriptions (continued)**

Address	Acronym	Register Description
0x01C6 412C	RCPPIDMASTATEW3	RX CPPI DMA State Word 3
0x01C6 4130	RCPPIDMASTATEW4	RX CPPI DMA State Word 4
0x01C6 4134	RCPPIDMASTATEW5	RX CPPI DMA State Word 5
0x01C6 4138	RCPPIDMASTATEW6	RX CPPI DMA State Word 6
0x01C6 413C	RCPPICOMPTR	RX CPPI Completion Pointer
<b>TX/RX CCPI Channel 1 State Block</b>		
0x01C6 4140	TCPPIDMASTATEW0	TX CPPI DMA State Word 0
0x01C6 4144	TCPPIDMASTATEW1	TX CPPI DMA State Word 1
0x01C6 4148	TCPPIDMASTATEW2	TX CPPI DMA State Word 2
0x01C6 414C	TCPPIDMASTATEW3	TX CPPI DMA State Word 3
0x01C6 4150	TCPPIDMASTATEW4	TX CPPI DMA State Word 4
0x01C6 4154	TCPPIDMASTATEW5	TX CPPI DMA State Word 5
0x01C6 4158	TCPPIDMASTATEW6	TX CPPI DMA State Word 6
0x01C6 415C	TCPPICOMPTR	TX CPPI Completion Pointer
0x01C6 4160	RCPPIDMASTATEW0	RX CPPI DMA State Word 0
0x01C6 4164	RCPPIDMASTATEW1	RX CPPI DMA State Word 1
0x01C6 4168	RCPPIDMASTATEW2	RX CPPI DMA State Word 2
0x01C6 416C	RCPPIDMASTATEW3	RX CPPI DMA State Word 3
0x01C6 4170	RCPPIDMASTATEW4	RX CPPI DMA State Word 4
0x01C6 4174	RCPPIDMASTATEW5	RX CPPI DMA State Word 5
0x01C6 4178	RCPPIDMASTATEW6	RX CPPI DMA State Word 6
0x01C6 417C	RCPPICOMPTR	RX CPPI Completion Pointer
<b>TX/RX CCPI Channel 2 State Block</b>		
0x01C6 4180	TCPPIDMASTATEW0	TX CPPI DMA State Word 0
0x01C6 4184	TCPPIDMASTATEW1	TX CPPI DMA State Word 1
0x01C6 4188	TCPPIDMASTATEW2	TX CPPI DMA State Word 2
0x01C6 418C	TCPPIDMASTATEW3	TX CPPI DMA State Word 3
0x01C6 4190	TCPPIDMASTATEW4	TX CPPI DMA State Word 4
0x01C6 4194	TCPPIDMASTATEW5	TX CPPI DMA State Word 5
0x01C6 4198	TCPPIDMASTATEW6	TX CPPI DMA State Word 6
0x01C6 419C	TCPPICOMPTR	TX CPPI Completion Pointer
0x01C6 41A0	RCPPIDMASTATEW0	RX CPPI DMA State Word 0
0x01C6 41A4	RCPPIDMASTATEW1	RX CPPI DMA State Word 1
0x01C6 41A8	RCPPIDMASTATEW2	RX CPPI DMA State Word 2
0x01C6 41AC	RCPPIDMASTATEW3	RX CPPI DMA State Word 3
0x01C6 41BA	RCPPIDMASTATEW4	RX CPPI DMA State Word 4
0x01C6 41B4	RCPPIDMASTATEW5	RX CPPI DMA State Word 5
0x01C6 41B8	RCPPIDMASTATEW6	RX CPPI DMA State Word 6
0x01C6 41BC	RCPPICOMPTR	RX CPPI Completion Pointer
<b>TX/RX CCPI Channel 3 State Block</b>		
0x01C6 41C0	TCPPIDMASTATEW0	TX CPPI DMA State Word 0
0x01C6 41C4	TCPPIDMASTATEW1	TX CPPI DMA State Word 1
0x01C6 41C8	TCPPIDMASTATEW2	TX CPPI DMA State Word 2
0x01C6 41CC	TCPPIDMASTATEW3	TX CPPI DMA State Word 3
0x01C6 41D0	TCPPIDMASTATEW4	TX CPPI DMA State Word 4
0x01C6 41D4	TCPPIDMASTATEW5	TX CPPI DMA State Word 5
0x01C6 41D8	TCPPIDMASTATEW6	TX CPPI DMA State Word 6



**Table 6-71. USB 2.0 Register Descriptions (continued)**

Address	Acronym	Register Description
0x01C6 41DC	TCPPICOMPTR	TX CPPI Completion Pointer
0x01C6 41E0	RCPPIDMASTATEW0	RX CPPI DMA State Word 0
0x01C6 41E4	RCPPIDMASTATEW1	RX CPPI DMA State Word 1
0x01C6 41E8	RCPPIDMASTATEW2	RX CPPI DMA State Word 2
0x01C6 41EC	RCPPIDMASTATEW3	RX CPPI DMA State Word 3
0x01C6 41F0	RCPPIDMASTATEW4	RX CPPI DMA State Word 4
0x01C6 41F4	RCPPIDMASTATEW5	RX CPPI DMA State Word 5
0x01C6 41F8	RCPPIDMASTATEW6	RX CPPI DMA State Word 6
0x01C6 41FC	RCPPICOMPTR	RX CPPI Completion Pointer
<b>Core Registers</b>		
0x01C6 4400	FADDR	Function Address Register
0x01C6 4401	POWER	Power Management Register
0x01C6 4402	INTRTX	Interrupt Register for Endpoint 0 plus TX Endpoints 1 to 4
0x01C6 4404	INTRRX	Interrupt Register for RX Endpoints 1 to 4
0x01C6 4406	INTRTXE	Interrupt Enable Register for INTRTX
0x01C6 4408	INTRRXE	Interrupt Enable Register for INTRRX
0x01C6 440A	INTRUSB	Interrupt Register for Common USB Interrupts
0x01C6 440B	INTRUSBE	Interrupt Enable Register for INTRUSB
0x01C6 440C	FRAME	Frame Number Register
0x01C6 440E	INDEX	Index register for selecting the endpoint status and control registers
0x01C6 440F	TESTMODE	Register to enable the USB 2.0 test modes
0x01C6 4410	TXMAXP	Maximum packet size for peripheral/host TX endpoint (Index register set to select Endpoints 1 - 4 only)
0x01C6 4412	PERI_CSR0	Control Status register for Endpoint 0 in Peripheral mode. (Index register set to select Endpoint 0)
	HOST_CSR0	Control Status register for Endpoint 0 in Host mode. (Index register set to select Endpoint 0)
	PERI_TXCSR	Control Status register for peripheral TX endpoint. (Index register set to select Endpoints 1 - 4)
	HOST_TXCSR	Control Status register for host TX endpoint. (Index register set to select Endpoints 1 - 4)
0x01C6 4414	RXMAXP	Maximum packet size for peripheral/host RX endpoint (Index register set to select Endpoints 1 - 4 only)
0x01C6 4416	PERI_RXCSR	Control Status register for peripheral RX endpoint. (Index register set to select Endpoints 1 - 4)
	HOST_RXCSR	Control Status register for host RX endpoint. (Index register set to select Endpoints 1 - 4)
0x01C6 4418	COUNT0	Number of received bytes in Endpoint 0 FIFO. (Index register set to select Endpoint 0)
	RXCOUNT	Number of bytes in host RX endpoint FIFO. (Index register set to select Endpoints 1 - 4)
0x01C6 441A	HOST_TYPE0	Defines the speed of Endpoint 0
0x01C6 441A	HOST_TXTYPE	Sets the operating speed, transaction protocol and peripheral endpoint number for the host TX endpoint. (Index register set to select Endpoints 1 - 4 only)
0x01C6 441B	HOST_NAKLIMIT0	Sets the NAK response timeout on Endpoint 0. (Index register set to select Endpoint 0)
0x01C6 441B	HOST_TXINTERVAL	Sets the polling interval for Interrupt/ISOC transactions or the NAK response timeout on Bulk transactions for host TX endpoint. (Index register set to select Endpoints 1 - 4 only)
0x01C6 441C	HOST_RXTYPE	Sets the operating speed, transaction protocol and peripheral endpoint number for the host RX endpoint. (Index register set to select Endpoints 1 - 4 only)

**Table 6-71. USB 2.0 Register Descriptions (continued)**

Address	Acronym	Register Description
0x01C6 441D	HOST_RXINTERVAL	Sets the polling interval for Interrupt/ISOC transactions or the NAK response timeout on Bulk transactions for host RX endpoint. (Index register set to select Endpoints 1 - 4 only)
0x01C6 441F	CONFIGDATA	Returns details of core configuration (Index register set to select Endpoint 0)
0x01C6 4420	FIFO0	TX and RX FIFO Register for Endpoint 0
0x01C6 4424	FIFO1	TX and RX FIFO Register for Endpoint 1
0x01C6 4428	FIFO2	TX and RX FIFO Register for Endpoint 2
0x01C6 442C	FIFO3	TX and RX FIFO Register for Endpoint 3
0x01C6 4430	FIFO4	TX and RX FIFO Register for Endpoint 4
0x01C6 4462	TXFIFOSZ	TX Endpoint FIFO Size (Index register set to select Endpoints 0 - 4 only)
0x01C6 4463	RXFIFOSZ	RX Endpoint FIFO Size (Index register set to select Endpoints 0 - 4 only)
0x01C6 4464	TXFIFOADDR	TX Endpoint FIFO Address (Index register set to select Endpoints 0 - 4 only)
0x01C6 4466	RXFIFOADDR	RX Endpoint FIFO Address (Index register set to select Endpoints 0 - 4 only)
<b>Target Endpoint Control Registers (Valid Only in Host Mode) - EPTRG0</b>		
0x01C6 4480	TXFUNCADDR	Address of the target function that has to be accessed through the associated TX Endpoint
0x01C6 4482	TXHUBADDR	Address of the hub that has to be accessed through the associated TX Endpoint. This is used only when full speed or low speed device is connected via a USB2.0 high speed hub
0x01C6 4483	TXHUBPORT	Port of the hub that has to be accessed through the associated TX Endpoint. This is used only when full speed or low speed device is connected via a USB2.0 high speed hub
0x01C6 4484	RXFUNCADDR	Address of the target function that has to be accessed through the associated RX Endpoint
0x01C6 4486	RXHUBADDR	Address of the hub that has to be accessed through the associated RX Endpoint. This is used only when full speed or low speed device is connected via a USB2.0 high speed hub
0x01C6 4487	RXHUBPORT	Port of the hub that has to be accessed through the associated RX Endpoint. This is used only when full speed or low speed device is connected via a USB2.0 high speed hub
<b>Target Endpoint Control Registers (Valid Only in Host Mode) - EPTRG1</b>		
0x01C6 4488	TXFUNCADDR	Address of the target function that has to be accessed through the associated TX Endpoint
0x01C6 448A	TXHUBADDR	Address of the hub that has to be accessed through the associated TX Endpoint. This is used only when full speed or low speed device is connected via a USB2.0 high speed hub
0x01C6 448B	TXHUBPORT	Port of the hub that has to be accessed through the associated TX Endpoint. This is used only when full speed or low speed device is connected via a USB2.0 high speed hub
0x01C6 448C	RXFUNCADDR	Address of the target function that has to be accessed through the associated RX Endpoint
0x01C6 448E	RXHUBADDR	Address of the hub that has to be accessed through the associated RX Endpoint. This is used only when full speed or low speed device is connected via a USB2.0 high speed hub
0x01C6 448F	RXHUBPORT	Port of the hub that has to be accessed through the associated RX Endpoint. This is used only when full speed or low speed device is connected via a USB2.0 high speed hub
<b>Target Endpoint Control Registers (Valid Only in Host Mode) - EPTRG2</b>		
0x01C6 4490	TXFUNCADDR	Address of the target function that has to be accessed through the associated TX Endpoint
0x01C6 4492	TXHUBADDR	Address of the hub that has to be accessed through the associated TX Endpoint. This is used only when full speed or low speed device is connected via a USB2.0 high speed hub
0x01C6 4493	TXHUBPORT	Port of the hub that has to be accessed through the associated TX Endpoint. This is used only when full speed or low speed device is connected via a USB2.0 high speed hub

**Table 6-71. USB 2.0 Register Descriptions (continued)**

Address	Acronym	Register Description
0x01C6 4494	RXFUNCADDR	Address of the target function that has to be accessed through the associated RX Endpoint
0x01C6 4496	RXHUBADDR	Address of the hub that has to be accessed through the associated RX Endpoint. This is used only when full speed or low speed device is connected via a USB2.0 high speed hub
0x01C6 4497	RXHUBPORT	Port of the hub that has to be accessed through the associated RX Endpoint. This is used only when full speed or low speed device is connected via a USB2.0 high speed hub
<b>Target Endpoint Control Registers (Valid Only in Host Mode) - EPTRG3</b>		
0x01C6 4498	TXFUNCADDR	Address of the target function that has to be accessed through the associated TX Endpoint
0x01C6 449A	TXHUBADDR	Address of the hub that has to be accessed through the associated TX Endpoint. This is used only when full speed or low speed device is connected via a USB2.0 high speed hub
0x01C6 449B	TXHUBPORT	Port of the hub that has to be accessed through the associated TX Endpoint. This is used only when full speed or low speed device is connected via a USB2.0 high speed hub
0x01C6 449C	RXFUNCADDR	Address of the target function that has to be accessed through the associated RX Endpoint
0x01C6 449E	RXHUBADDR	Address of the hub that has to be accessed through the associated RX Endpoint. This is used only when full speed or low speed device is connected via a USB2.0 high speed hub
0x01C6 449F	RXHUBPORT	Port of the hub that has to be accessed through the associated RX Endpoint. This is used only when full speed or low speed device is connected via a USB2.0 high speed hub
<b>Target Endpoint Control Registers (Valid Only in Host Mode) - EPTRG4</b>		
0x01C6 44A0	TXFUNCADDR	Address of the target function that has to be accessed through the associated TX Endpoint
0x01C6 44A2	TXHUBADDR	Address of the hub that has to be accessed through the associated TX Endpoint. This is used only when full speed or low speed device is connected via a USB2.0 high speed hub
0x01C6 44A3	TXHUBPORT	Port of the hub that has to be accessed through the associated TX Endpoint. This is used only when full speed or low speed device is connected via a USB2.0 high speed hub
0x01C6 44A4	RXFUNCADDR	Address of the target function that has to be accessed through the associated RX Endpoint
0x01C6 44A6	RXHUBADDR	Address of the hub that has to be accessed through the associated RX Endpoint. This is used only when full speed or low speed device is connected via a USB2.0 high speed hub
0x01C6 44A7	RXHUBPORT	Port of the hub that has to be accessed through the associated RX Endpoint. This is used only when full speed or low speed device is connected via a USB2.0 high speed hub
<b>Control and Status Register for Endpoint 0 - EOCSR0</b>		
0x01C6 4502	PERI_CSR0	Control Status Register for Endpoint 0 in Peripheral mode
	HOST_CSR0	Control Status Register for Endpoint 0 in Host mode
0x01C6 4508	COUNT0	Number of Received Bytes in Endpoint 0 FIFO
0x01C6 450A	HOST_TYPE0	Defines the Speed of Endpoint 0
0x01C6 450B	HOST_NAKLIMIT0	Sets the NAK response timeout on Endpoint 0.
0x01C6 450F	CONFIGDATA	Returns details of core configuration
<b>Control and Status Register for Endpoint 1 - EOCSR1</b>		
0x01C6 4510	TXMAXP	Maximum Packet size for Peripheral/Host TX Endpoint
0x01C6 4512	PERI_TXCSR	Control Status Register for Peripheral TX Endpoint
	HOST_TXCSR	Control Status Register for Host TX Endpoint
0x01C6 4514	RXMAXP	Maximum Packet Size for Peripheral/Host RX Endpoint

**Table 6-71. USB 2.0 Register Descriptions (continued)**

Address	Acronym	Register Description
0x01C6 4516	PERI_RXCSR	Control Status Register for Peripheral RX Endpoint
	HOST_RXCSR	Control Status Register for Host RX Endpoint
0x01C6 4518	RXCOUNT	Number of Bytes in Host RX Endpoint FIFO
0x01C6 451A	HOST_TXTYPE	Sets the operating speed, transaction protocol and peripheral endpoint number for the host TX endpoint.
0x01C6 451B	HOST_TXINTERVAL	Sets the polling interval for Interrupt/ISOC transactions or the NAK response timeout on Bulk transactions for host TX endpoint.
0x01C6 451C	HOST_RXTYPE	Sets the operating speed, transaction protocol and peripheral endpoint number for the host RX endpoint.
0x01C6 451D	HOST_RXINTERVAL	Sets the polling interval for Interrupt/ISOC transactions or the NAK response timeout on Bulk transactions for host RX endpoint.
<b>Control and Status Register for Endpoint 2 - EOCSR2</b>		
0x01C6 4520	TXMAXP	Maximum Packet Size for Peripheral/Host TX Endpoint
0x01C6 4522	PERI_TXCSR	Control Status Register for Peripheral TX Endpoint
	HOST_TXCSR	Control Status Register for Host TX Endpoint
0x01C6 4524	RXMAXP	Maximum Packet Size for Peripheral/Host RX Endpoint
0x01C6 4526	PERI_RXCSR	Control Status Register for Peripheral RX Endpoint
	HOST_RXCSR	Control Status Register for Host RX Endpoint
0x01C6 4528	RXCOUNT	Number of Bytes in Host RX Endpoint FIFO
0x01C6 452A	HOST_TXTYPE	Sets the operating speed, transaction protocol and peripheral endpoint number for the host TX endpoint.
0x01C6 452B	HOST_TXINTERVAL	Sets the polling interval for Interrupt/ISOC transactions or the NAK response timeout on Bulk transactions for host TX endpoint.
0x01C6 452C	HOST_RXTYPE	Sets the operating speed, transaction protocol and peripheral endpoint number for the host RX endpoint.
0x01C6 452D	HOST_RXINTERVAL	Sets the polling interval for Interrupt/ISOC transactions or the NAK response timeout on Bulk transactions for host RX endpoint.
<b>Control and Status Register for Endpoint 3 - EOCSR3</b>		
0x01C6 4530	TXMAXP	Maximum Packet Size for Peripheral/Host TX Endpoint
0x01C6 4532	PERI_TXCSR	Control Status Register for Peripheral TX Endpoint
	HOST_TXCSR	Control Status Register for Host TX Endpoint
0x01C6 4534	RXMAXP	Maximum Packet Size for Peripheral/Host RX Endpoint
0x01C6 4536	PERI_RXCSR	Control Status Register for Peripheral RX Endpoint
	HOST_RXCSR	Control Status Register for Host RX Endpoint
0x01C6 4538	RXCOUNT	Number of Bytes in Host RX Endpoint FIFO
0x01C6 453A	HOST_TXTYPE	Sets the operating speed, transaction protocol and peripheral endpoint number for the host TX endpoint.
0x01C6 453B	HOST_TXINTERVAL	Sets the polling interval for Interrupt/ISOC transactions or the NAK response timeout on Bulk transactions for host TX endpoint.
0x01C6 453C	HOST_RXTYPE	Sets the operating speed, transaction protocol and peripheral endpoint number for the host RX endpoint.
0x01C6 453D	HOST_RXINTERVAL	Sets the polling interval for Interrupt/ISOC transactions or the NAK response timeout on Bulk transactions for host RX endpoint.
<b>Control and Status Register for Endpoint 4 - EOCSR4</b>		
0x01C6 4540	TXMAXP	Maximum Packet Size for Peripheral/Host TX Endpoint
0x01C6 4542	PERI_TXCSR	Control Status Register for Peripheral TX Endpoint
	HOST_TXCSR	Control Status Register for Host TX Endpoint
0x01C6 4544	RXMAXP	Maximum Packet Size for Peripheral/Host RX Endpoint
0x01C6 4546	PERI_RXCSR	Control Status Register for Peripheral RX Endpoint
	HOST_RXCSR	Control Status Register for Host RX Endpoint
0x01C6 4548	RXCOUNT	Number of Bytes in Host RX Endpoint FIFO

**Table 6-71. USB 2.0 Register Descriptions (continued)**

Address	Acronym	Register Description
0x01C6 454A	HOST_TXTYPE	Sets the operating speed, transaction protocol and peripheral endpoint number for the host TX endpoint.
0x01C6 454B	HOST_TXINTERVAL	Sets the polling interval for Interrupt/ISOC transactions or the NAK response timeout on Bulk transactions for host TX endpoint.
0x01C6 454C	HOST_RXTYPE	Sets the operating speed, transaction protocol and peripheral endpoint number for the host RX endpoint.
0x01C6 454D	HOST_RXINTERVAL	Sets the polling interval for Interrupt/ISOC transactions or the NAK response timeout on Bulk transactions for host RX endpoint.

**6.15.3 USB2.0 Electrical Data/Timing**

**Table 6-72. Switching Characteristics Over Recommended Operating Conditions for USB2.0 (see Figure 6-59)**

NO.	PARAMETER	LOW SPEED 1.5 Mbps		FULL SPEED 12 Mbps		HIGH SPEED 480 Mbps		UNIT
		MIN	MAX	MIN	MAX	MIN	MAX	
1	$t_{r(D)}$ Rise time, USB_DP and USB_DM signals <sup>(1)</sup>	75	300	4	20	0.5		ns
2	$t_{f(D)}$ Fall time, USB_DP and USB_DM signals <sup>(1)</sup>	75	300	4	20	0.5		ns
3	$t_{rFM}$ Rise/Fall time, matching <sup>(2)</sup>	80	125	90	111.11	–	–	%
4	$V_{CRS}$ Output signal cross-over voltage <sup>(1)</sup>	1.3	2	1.3	2	–	–	V
5	$t_{j(source)NT}$ Source (Host) Driver jitter, next transition		2		2			<sup>(3)</sup> ns
	$t_{j(FUNC)NT}$ Function Driver jitter, next transition		25		2			<sup>(3)</sup> ns
6	$t_{j(source)PT}$ Source (Host) Driver jitter, paired transition <sup>(4)</sup>		1		1			<sup>(3)</sup> ns
	$t_{j(FUNC)PT}$ Function Driver jitter, paired transition		10		1			<sup>(3)</sup> ns
7	$t_w(EOPT)$ Pulse duration, EOP transmitter	1250	1500	160	175	–	–	ns
8	$t_w(EOPR)$ Pulse duration, EOP receiver	670		82		–		ns
9	$t_{(DRATE)}$ Data Rate		1.5		12		480	Mb/s
10	$Z_{DRV}$ Driver Output Resistance	–	–	28	49.5	40.5	49.5	$\Omega$
11	USB_R1 USB reference resistor	9.9	10.1	9.9	10.1	9.9	10.1	k $\Omega$

- (1) Low Speed:  $C_L = 200$  pF, Full Speed:  $C_L = 50$  pF, High Speed:  $C_L = 50$  pF
- (2)  $t_{RFM} = (t_r/t_f) \times 100$ . [Excluding the first transaction from the Idle state.]
- (3) For more detailed information, see the Universal Serial Bus Specification Revision 2.0, Chapter 7. Electrical.
- (4)  $t_{jr} = t_{px(1)} - t_{px(0)}$

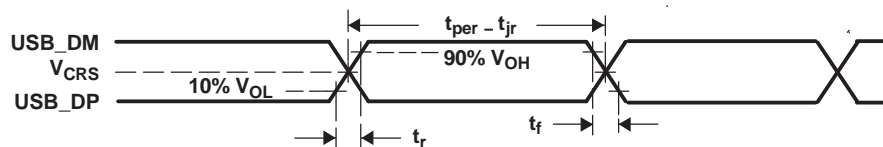

**Figure 6-59. USB2.0 Integrated Transceiver Interface Timing**

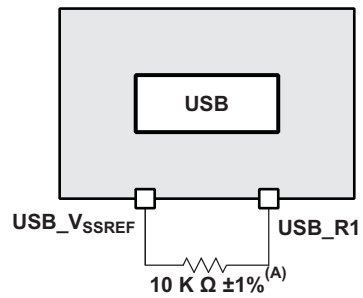

A. Place the 10 K  $\Omega$   $\pm$  1% as close to the device as possible.

**Figure 6-60. USB Reference Resistor Routing**

## 6.16 Universal Asynchronous Receiver/Transmitter (UART)

DM6446 has 3 UART peripherals. Each UART has the following features:

- 16-byte storage space for both the transmitter and receiver FIFOs
- 1, 4, 8, or 14 byte selectable receiver FIFO trigger level for autoflow control and DMA
- DMA signaling capability for both received and transmitted data
- Programmable auto-rts and auto-cts for autoflow control
- Frequency pre-scale values from 1 to 65,535 to generate appropriate baud rates
- Prioritized interrupts
- Programmable serial data formats
  - 5, 6, 7, or 8-bit characters
  - Even, odd, or no parity bit generation and detection
  - 1, 1.5, or 2 stop bit generation
- False start bit detection
- Line break generation and detection
- Internal diagnostic capabilities
  - Loopback controls for communications link fault isolation
  - Break, parity, overrun, and framing error simulation
- Modem control functions (CTS, RTS) on **UART2 only**.

The UART0/1/2 registers are listed in [Table 6-73](#), [Table 6-74](#), and [Table 6-75](#).

### 6.16.1 UART Peripheral Register Description(s)

**Table 6-73. UART0 Register Descriptions**

HEX ADDRESS RANGE	ACRONYM	REGISTER NAME
0x01C2 0000	RBR	UART0 Receiver Buffer Register (Read Only)
0x01C2 0000	THR	UART0 Transmitter Holding Register (Write Only)
0x01C2 0004	IER	UART0 Interrupt Enable Register
0x01C2 0008	IIR	UART0 Interrupt Identification Register (Read Only)
0x01C2 0008	FCR	UART0 FIFO Control Register (Write Only)
0x01C2 000C	LCR	UART0 Line Control Register
0x01C2 0010	MCR	UART0 Modem Control Register
0x01C2 0014	LSR	UART0 Line Status Register
0x01C2 0018	-	Reserved
0x01C2 001C	-	Reserved
0x01C2 0020	DLL	UART0 Divisor Latch (LSB)
0x01C2 0024	DLH	UART0 Divisor Latch (MSB)
0x01C2 0028	PID1	Peripheral Identification Register 1
0x01C2 002C	PID2	Peripheral Identification Register 2
0x01C2 0030	PWREMU_MGMT	UART0 Power and Emulation Management Register
0x01C2 0034 - 0x01C2 03FF	-	Reserved

**Table 6-74. UART1 Register Descriptions**

HEX ADDRESS RANGE	ACRONYM	REGISTER NAME
0x01C2 0400	RBR	UART1 Receiver Buffer Register (Read Only)
0x01C2 0400	THR	UART1 Transmitter Holding Register (Write Only)
0x01C2 0404	IER	UART1 Interrupt Enable Register
0x01C2 0408	IIR	UART1 Interrupt Identification Register (Read Only)

**Table 6-74. UART1 Register Descriptions (continued)**

HEX ADDRESS RANGE	ACRONYM	REGISTER NAME
0x01C2 0408	FCR	UART1 FIFO Control Register (Write Only)
0x01C2 040C	LCR	UART1 Line Control Register
0x01C2 0410	MCR	UART1 Modem Control Register
0x01C2 0414	LSR	UART1 Line Status Register
0x01C2 0418	-	Reserved
0x01C2 041C	-	Reserved
0x01C2 0420	DLL	UART1 Divisor Latch (LSB)
0x01C2 0424	DLH	UART1 Divisor Latch (MSB)
0x01C2 0428	PID1	Peripheral Identification Register 1
0x01C2 042C	PID2	Peripheral Identification Register 2
0x01C2 0430	PWREMU_MGMT	UART1 Power and Emulation Management Register
0x01C2 0434 - 0x01C2 07FF	-	Reserved

**Table 6-75. UART2 Register Descriptions**

HEX ADDRESS RANGE	ACRONYM	REGISTER NAME
0x01C2 0800	RBR	UART2 Receiver Buffer Register (Read Only)
0x01C2 0800	THR	UART2 Transmitter Holding Register (Write Only)
0x01C2 0804	IER	UART2 Interrupt Enable Register
0x01C2 0808	IIR	UART2 Interrupt Identification Register (Read Only)
0x01C2 0808	FCR	UART2 FIFO Control Register (Write Only)
0x01C2 080C	LCR	UART2 Line Control Register
0x01C2 0810	MCR	UART2 Modem Control Register
0x01C2 0814	LSR	UART2 Line Status Register
0x01C2 0818	-	Reserved
0x01C2 081C	-	Reserved
0x01C2 0820	DLL	UART2 Divisor Latch (LSB)
0x01C2 0824	DLH	UART2 Divisor Latch (MSB)
0x01C2 0828	PID1	Peripheral Identification Register 1
0x01C2 082C	PID2	Peripheral Identification Register 2
0x01C2 0830	PWREMU_MGMT	UART2 Power and Emulation Management Register
0x01C2 0834 - 0x01C2 0BFF	-	Reserved



### 6.16.2 UART Electrical Data/Timing

**Table 6-76. Timing Requirements for UARTx Receive<sup>(1)</sup> (see Figure 6-61)**

NO.		MIN	MAX	UNIT
4	$t_w(\text{URXDB})$ Pulse duration, receive data bit (RXDn) [15/30/100 pF]	0.96U	1.05U	ns
5	$t_w(\text{URXSB})$ Pulse duration, receive start bit [15/30/100 pF]	0.96U	1.05U	ns

(1) U = UART baud time = 1/programmed baud rate.

**Table 6-77. Switching Characteristics Over Recommended Operating Conditions for UARTx Transmit<sup>(1)</sup> (see Figure 6-61)**

NO.	PARAMETER	MIN	MAX	UNIT
1	$f_{(\text{baud})}$ Maximum programmable baud rate		128	kHz
2	$t_w(\text{UTXDB})$ Pulse duration, transmit data bit (TXDn) [15/30/100 pF]	U - 2	U + 2	ns
3	$t_w(\text{UTXSB})$ Pulse duration, transmit start bit [15/30/100 pF]	U - 2	U + 2	ns

(1) U = UART baud time = 1/programmed baud rate.

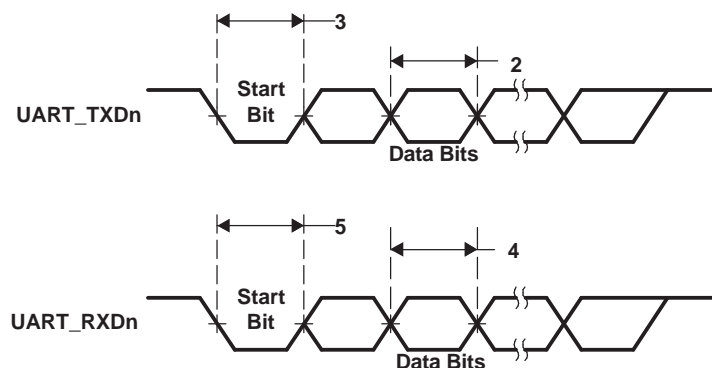

**Figure 6-61. UART Transmit/Receive Timing**

## 6.17 Serial Peripheral Interface (SPI)

The DM6446 SPI peripheral provides a programmable length shift register which allows serial communication with other SPI devices through a 3 or 4 wire interface. The SPI supports the following features:

- Master mode operation
- 2 chip selects for interfacing to multiple slave SPI devices.
- 3 or 4 wire interface

The SPI registers are shown in [Table 6-78](#).

### 6.17.1 SPI Peripheral Register Description(s)

**Table 6-78. SPI Register Descriptions**

HEX ADDRESS RANGE	ACRONYM	REGISTER NAME
0x01C6 6800	SPIGCR0	SPI Global Control Register 0
0x01C6 6804	SPIGCR1	SPI Global Control Register 1
0x01C6 6808	SPIINT	SPI Interrupt Register
0x01C6 680C	SPIVLV	SPI Interrupt Level Register
0x01C6 6810	SPIFLG	SPI Flag Status Register
0x01C6 6814	SPIPC0	SPI Pin Control Register 0
0x01C6 6818	–	Reserved
0x01C6 681C	SPIPC2	SPI Pin Control Register 2
0x01C6 6820 - 0x01C6 6838	–	Reserved
0x01C6 683C	SPIDAT1	SPI Shift Register 1
0x01C6 6840	SPIBUF	SPI Buffer Register
0x01C6 6844	SPIEMU	SPI Emulation Register
0x01C6 6848	SPIDELAY	SPI Delay Register
0x01C6 684C	SPIDEF	SPI Default Chip Select Register
0x01C6 6850	SPIFMT0	SPI Data Format Register 0
0x01C6 6854	SPIFMT1	SPI Data Format Register 1
0x01C6 6858	SPIFMT2	SPI Data Format Register 2
0x01C6 685C	SPIFMT3	SPI Data Format Register 3
0x01C6 6860	INTVEC0	SPI Interrupt Vector Register 0
0x01C6 6864	INTVEC1	SPI Interrupt Vector Register 1
0x01C6 6868 - 0x01C6 6FFF		Reserved

### 6.17.2 SPI Electrical Data/Timing

**Table 6-79. Timing Requirements for SPI (All Modes)<sup>(1)</sup> (see [Figure 6-62](#))**

NO.		MIN	MAX	UNIT
1	$t_{c(CLK)}$ Cycle time, SPI_CLK	30.3	56888.89	ns
2	$t_{w(CLKH)}$ Pulse duration, SPI_CLK high (All Master Modes)	0.45*T	0.55*T	ns
3	$t_{w(CLKL)}$ Pulse duration, SPI_CLK low (All Master Modes)	0.45*T	0.55*T	ns

(1)  $T = t_{c(CLK)}$  [SPI\_CLK period is equal to the SPI module clock divided by a configurable divider.]

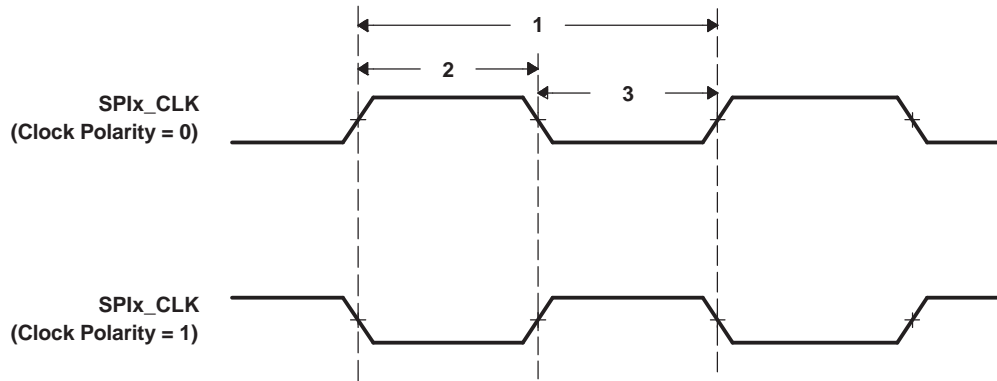

Figure 6-62. SPI\_CLK Timing

6.17.2.1 SPI Master Mode Timings (Clock Phase = 0)

Table 6-80. Timing Requirements for SPI Master Mode [Clock Phase = 0] <sup>(1)</sup>(see Figure 6-63)

NO.			MIN	MAX	UNIT
4	$t_{su(DIV-CLKL)}$	Setup time, SPI_DI (input) valid before SPI_CLK (output) falling edge	Clock Polarity = 0	$0.5P + 9.4$	ns
5	$t_{su(DIV-CLKH)}$	Setup time, SPI_DI (input) valid before SPI_CLK (output) rising edge	Clock Polarity = 1	$0.5P + 9.4$	ns
6	$t_{h(CLKL-DIV)}$	Hold time, SPI_DI (input) valid after SPI_CLK (output) falling edge	Clock Polarity = 0	$0.5P - 4.5$	ns
7	$t_{h(CLKH-DIV)}$	Hold time, SPI_DI (input) valid after SPI_CLK (output) rising edge	Clock Polarity = 1	$0.5P - 4.5$	ns

(1) P = Period of the SPI module clock in nanoseconds (SYSCLK5).

**Table 6-81. Switching Characteristics Over Recommended Operating Conditions for SPI Master Mode [Clock Phase = 0] (see Figure 6-63)**

NO.	PARAMETER		MIN	MAX	UNIT	
8	$t_{d(CLKH-DOV)}$	Delay time, SPI_CLK (output) rising edge to SPI_DO (output) transition		-4	5	ns
9	$t_{d(CLKL-DOV)}$	Delay time, SPI_CLK (output) falling edge to SPI_DO (output) transition		-4	5	ns
10	$t_{d(ENL-CLKH/L)}$	Delay time, SPI_EN[1:0] (output) falling edge to first SPI_CLK (output) rising or falling edge <sup>(1)(2)</sup>	2P - 2.3			ns
11	$t_{d(CLKH/L-ENH)}$	Delay time, SPI_CLK (output) rising or falling edge to SPI_EN[1:0] (output) rising edge <sup>(1)(2)(3)</sup>	1P + 0.5C - 0.2			ns

- (1) P = Period of the SPI module clock in nanoseconds (SYSCLK5).
- (2) This delay can be increased under software control by the C2TDELAY register bit field in the SPIDELAY register.
- (3) C = Period of SPI\_CLK signal in ns.

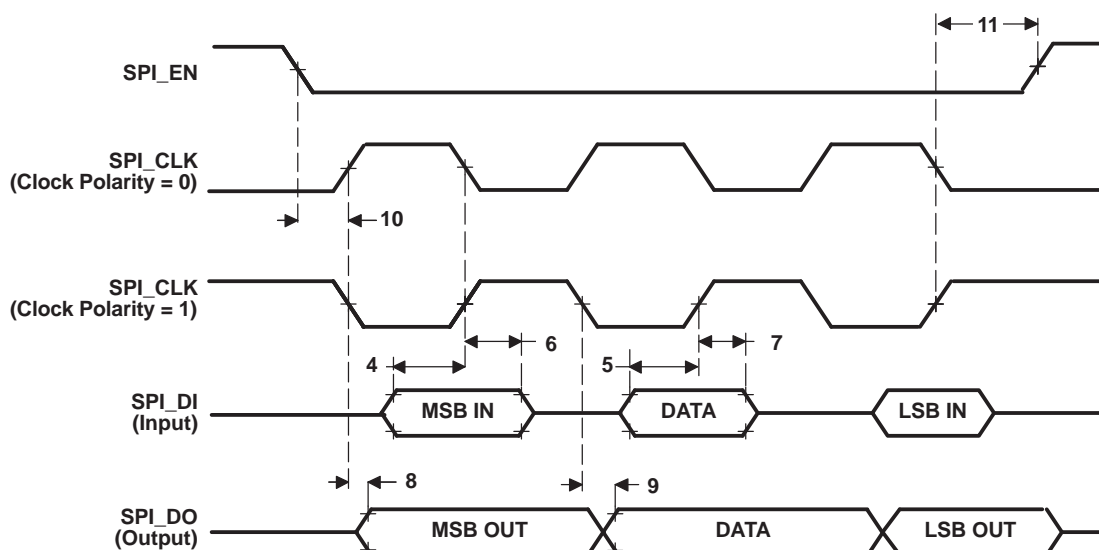

**Figure 6-63. SPI Master Mode External Timing (Clock Phase = 0)**

### 6.17.2.2 SPI Master Mode Timings (Clock Phase = 1)

**Table 6-82. Timing Requirements for SPI Master Mode [Clock Phase = 1]<sup>(1)</sup> (see Figure 6-64)**

NO.	PARAMETER		MIN	MAX	UNIT
13	$t_{su(DIV-CLKL)}$	Setup time, SPI_DI (input) valid before SPI_CLK (output) rising edge	0.5P + 9.4		ns
14	$t_{su(DIV-CLKH)}$	Setup time, SPI_DI (input) valid before SPI_CLK (output) falling edge	0.5P + 9.4		ns
15	$t_h(CLKL-DIV)$	Hold time, SPI_DI (input) valid after SPI_CLK (output) rising edge	0.5P - 4.5		ns
16	$t_h(CLKH-DIV)$	Hold time, SPI_DI (input) valid after SPI_CLK (output) falling edge	0.5P - 4.5		ns

- (1) P = Period of the SPI module clock in nanoseconds (SYSCLK5).

**Table 6-83. Switching Characteristics Over Recommended Operating Conditions for SPI Master Mode [Clock Phase = 1] (see Figure 6-64)**

NO.	PARAMETER		MIN	MAX	UNIT	
17	$t_{d(CLKL-DOV)}$	Delay time, SPI_CLK (output) falling edge to SPI_DO (output) transition		-4	5	ns

**Table 6-83. Switching Characteristics Over Recommended Operating Conditions for SPI Master Mode [Clock Phase = 1] (see Figure 6-64) (continued)**

NO.	PARAMETER		MIN	MAX	UNIT
18	$t_{d(CLKH-DOV)}$	Delay time, SPI_CLK (output) rising edge to SPI_DO (output) transition Clock Polarity = 1	-4	5	ns
19	$t_{d(ENL-CLKH/L)}$	Delay time, SPI_EN[1:0] (output) falling edge to first SPI_CLK (output) rising or falling edge <sup>(1)(2)(3)</sup>	$2P + 0.5C - 2.3$		ns
20	$t_{d(CLKH/L-ENH)}$	Delay time, SPI_CLK (output) rising or falling edge to SPI_EN[1:0] (output) rising edge <sup>(1)(2)</sup>	$1P - 0.2$		ns

- (1) P = Period of the SPI module clock in nanoseconds (SYSCLK5).
- (2) This delay can be increased under software control by the C2TDELAY register bit field in the SPIDELAY register.
- (3) C = Period of SPI\_CLK signal in ns.

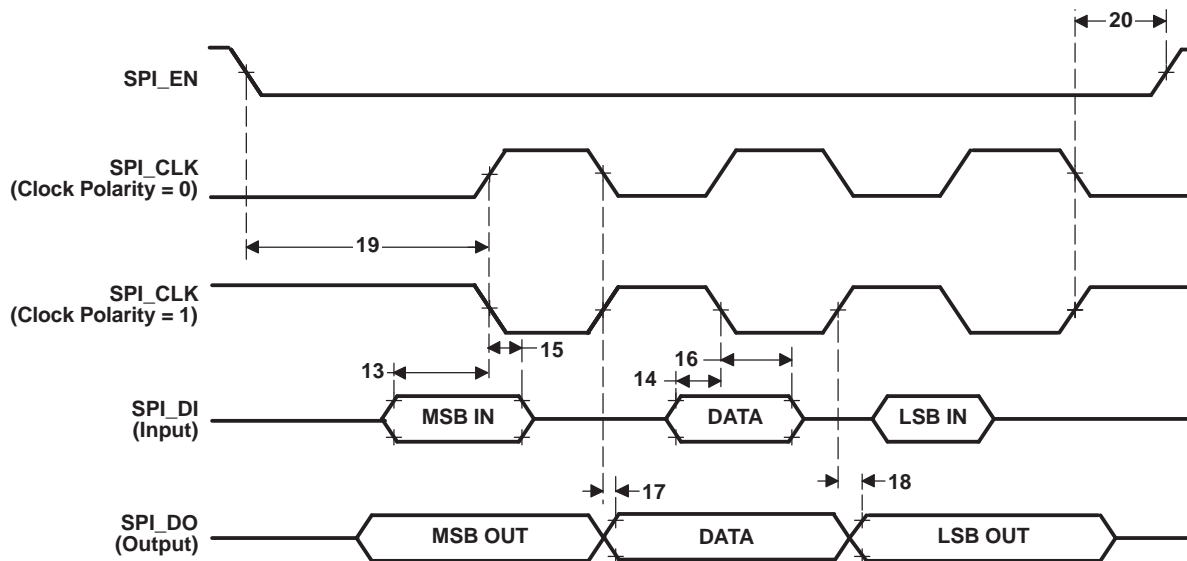

**Figure 6-64. SPI Master Mode External Timing (Clock Phase = 1)**

## 6.18 Inter-Integrated Circuit (I2C)

The inter-integrated circuit (I2C) module provides an interface between DM6446 and other devices compliant with Philips Semiconductors Inter-IC bus (I<sup>2</sup>C-bus™) specification version 2.1. External components attached to this 2-wire serial bus can transmit/receive up to 8-bit data to/from the DSP through the I2C module. The I2C port *does not* support CBUS compatible devices.

The I2C port supports:

- Compatible with Philips I2C Specification Revision 2.1 (January 2000)
- Fast Mode up to 400 Kbps (no fail-safe I/O buffers)
- Noise Filter to Remove Noise 50 ns or less
- Seven- and Ten-Bit Device Addressing Modes
- Master (Transmit/Receive) and Slave (Transmit/Receive) Functionality
- Events: DMA, Interrupt, or Polling
- Slew-Rate Limited Open-Drain Output Buffers

For more detailed information on the I2C peripheral, see the *TMS320DM644x DMSoC Peripherals Overview Reference Guide* (literature number [SPRUE19](#)).

### CAUTION

**The DM6446 I2C pins use a standard  $\pm 4$ -mA LVCMOS buffer, not the slow I/O buffer defined in the I2C specification. Series resistors may be necessary to reduce noise at the system level.**

### 6.18.1 I2C Peripheral Register Description(s)

**Table 6-84. I2C Registers**

HEX ADDRESS RANGE	ACRONYM	REGISTER NAME
0x1c2 1000	ICOAR	I2C Own Address Register
0x1c2 1004	ICIMR	I2C Interrupt Mask Register
0x1c2 1008	ICSTR	I2C Interrupt Status Register
0x1c2 100C	ICCLKL	I2C Clock Divider Low Register
0x1c2 1010	ICCLKH	I2C Clock Divider High Register
0x1c2 1014	ICCNT	I2C Data Count Register
0x1c2 1018	ICDRR	I2C Data Receive Register
0x1c2 101C	ICSAR	I2C Slave Address Register
0x1c2 1020	ICDXR	I2C Data Transmit Register
0x1c2 1024	ICMDR	I2C Mode Register
0x1c2 1028	ICIVR	I2C Interrupt Vector Register
0x1c2 102C	ICEMDR	I2C Extended Mode Register
0x1c2 1030	ICPSC	I2C Prescaler Register
0x1c2 1034	ICPID1	I2C Peripheral Identification Register 1
0x1c2 1038	ICPID2	I2C Peripheral Identification Register 2

## 6.18.2 I2C Electrical Data/Timing

### 6.18.2.1 Inter-Integrated Circuits (I2C) Timing

Table 6-85. Timing Requirements for I2C Timings<sup>(1)</sup> (see Figure 6-65)

NO.			STANDARD MODE		FAST MODE		UNIT
			MIN	MAX	MIN	MAX	
1	$t_{c(SCL)}$	Cycle time, SCL	10		2.5		$\mu$ s
2	$t_{su(SCLH-SDAL)}$	Setup time, SCL high before SDA low (for a repeated START condition)	4.7		0.6		$\mu$ s
3	$t_{h(SCLL-SDAL)}$	Hold time, SCL low after SDA low (for a START and a repeated START condition)	4		0.6		$\mu$ s
4	$t_{w(SCLL)}$	Pulse duration, SCL low	4.7		1.3		$\mu$ s
5	$t_{w(SCLH)}$	Pulse duration, SCL high	4		0.6		$\mu$ s
6	$t_{su(SDAV-SCLH)}$	Setup time, SDA valid before SCL high	250		100 <sup>(2)</sup>		ns
7	$t_{h(SDA-SCLL)}$	Hold time, SDA valid after SCL low	0 <sup>(3)</sup>		0 <sup>(3)</sup>	0.9 <sup>(4)</sup>	$\mu$ s
8	$t_{w(SDAH)}$	Pulse duration, SDA high between STOP and START conditions	4.7		1.3		$\mu$ s
9	$t_{r(SDA)}$	Rise time, SDA		1000	$20 + 0.1C_b$ <sup>(5)</sup>	300	ns
10	$t_{r(SCL)}$	Rise time, SCL		1000	$20 + 0.1C_b$ <sup>(5)</sup>	300	ns
11	$t_{f(SDA)}$	Fall time, SDA		300	$20 + 0.1C_b$ <sup>(5)</sup>	300	ns
12	$t_{f(SCL)}$	Fall time, SCL		300	$20 + 0.1C_b$ <sup>(5)</sup>	300	ns
13	$t_{su(SCLH-SDAH)}$	Setup time, SCL high before SDA high (for STOP condition)	4		0.6		$\mu$ s
14	$t_{w(SP)}$	Pulse duration, spike (must be suppressed)			0	50	ns
15	$C_b$ <sup>(5)</sup>	Capacitive load for each bus line		400		400	pF

- (1) The I2C pins SDA and SCL do not feature fail-safe I/O buffers. These pins could potentially draw current when the device is powered down.
- (2) A Fast-mode I<sup>2</sup>C-bus™ device can be used in a Standard-mode I<sup>2</sup>C-bus system, but the requirement  $t_{su(SDA-SCLH)} \geq 250$  ns must then be met. This will automatically be the case if the device does not stretch the LOW period of the SCL signal. If such a device does stretch the LOW period of the SCL signal, it must output the next data bit to the SDA line  $t_r$  max +  $t_{su(SDA-SCLH)} = 1000 + 250 = 1250$  ns (according to the Standard-mode I<sup>2</sup>C-Bus Specification) before the SCL line is released.
- (3) A device must internally provide a hold time of at least 300 ns for the SDA signal (referred to the  $V_{IHmin}$  of the SCL signal) to bridge the undefined region of the falling edge of SCL.
- (4) The maximum  $t_{h(SDA-SCLL)}$  has only to be met if the device does not stretch the low period [ $t_{w(SCLL)}$ ] of the SCL signal.
- (5)  $C_b$  = total capacitance of one bus line in pF. If mixed with HS-mode devices, faster fall-times are allowed.

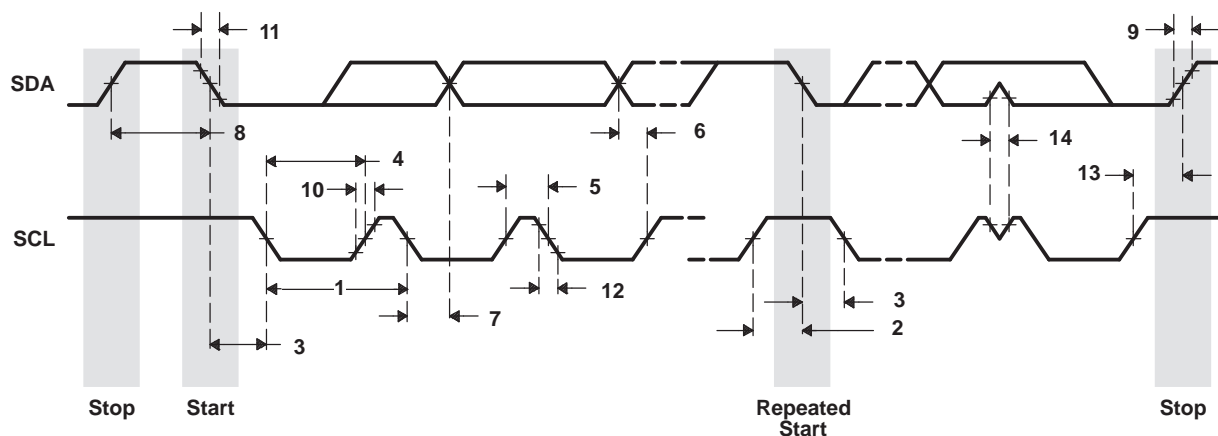

Figure 6-65. I2C Receive Timings



Table 6-86. Switching Characteristics for I2C Timings (see Figure 6-66)

NO.	PARAMETER		STANDARD MODE		FAST MODE		UNIT
			MIN	MAX	MIN	MAX	
16	$t_{c(SCL)}$	Cycle time, SCL	10		2.5		$\mu\text{s}$
17	$t_{d(SCLH-SDAL)}$	Delay time, SCL high to SDA low (for a repeated START condition)	4.7		0.6		$\mu\text{s}$
18	$t_{d(SDAL-SCLL)}$	Delay time, SDA low to SCL low (for a START and a repeated START condition)	4		0.6		$\mu\text{s}$
19	$t_{w(SCLL)}$	Pulse duration, SCL low	4.7		1.3		$\mu\text{s}$
20	$t_{w(SCLH)}$	Pulse duration, SCL high	4		0.6		$\mu\text{s}$
21	$t_{d(SDAV-SCLH)}$	Delay time, SDA valid to SCL high	250		100		ns
22	$t_{v(SCLL-SDAV)}$	Valid time, SDA valid after SCL low	0		0	0.9	$\mu\text{s}$
23	$t_{w(SDAH)}$	Pulse duration, SDA high between STOP and START conditions	4.7		1.3		$\mu\text{s}$
28	$t_{d(SCLH-SDAH)}$	Delay time, SCL high to SDA high (for STOP condition)	4		0.6		$\mu\text{s}$
29	$C_p$	Capacitance for each I2C pin		10		10	pF

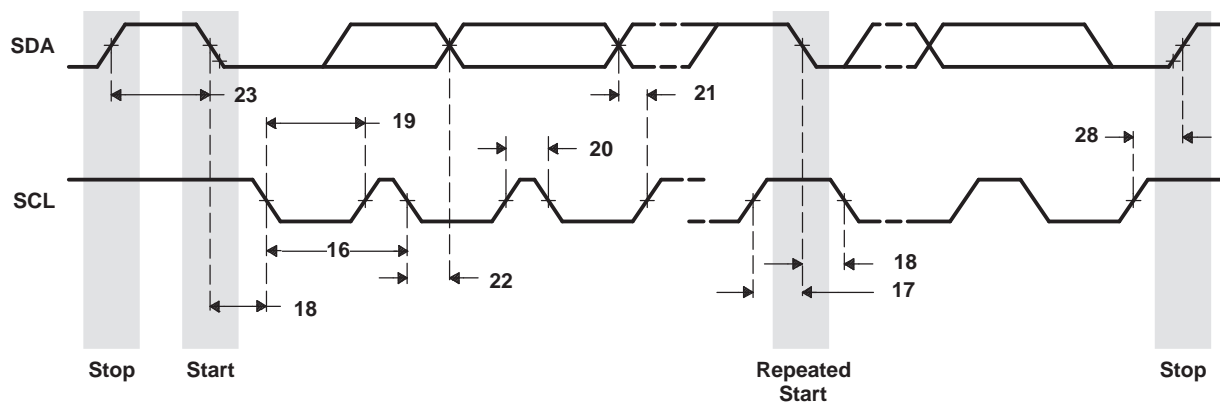

Figure 6-66. I2C Transmit Timings

**CAUTION**

The DM6446 I2C pins use a standard  $\pm 4\text{-mA}$  LVCMOS buffer, not the slow I/O buffer defined in the I2C specification. Series resistors may be necessary to reduce noise at the system level.

## 6.19 Audio Serial Port (ASP)

The ASP provides these functions:

- Full-duplex communication
- Double-buffered data registers, which allow a continuous data stream
- Independent framing and clocking for receive and transmit
- Direct interface to industry-standard codecs, analog interface chips (AICs), and other serially connected analog-to-digital (A/D) and digital-to-analog (D/A) devices
- External shift clock or an internal, programmable frequency shift clock for data transfer

For more detailed information on the ASP peripheral, see the *Documentation Support* section for the Audio Serial Port (ASP) Reference Guide.

### 6.19.1 ASP Peripheral Register Description(s)

**Table 6-87. ASP Register Descriptions**

HEX ADDRESS RANGE	ACRONYM	REGISTER NAME
0x01E0 2000	DRR	ASP Data Receive Register
0x01E0 2004	DXR	ASP Data Transmit Register
0x01E0 2008	SPCR	ASP Serial Port Control Register
0x01E0 200C	RCR	ASP Receive Control Register
0x01E0 2010	XCR	ASP Transmit Control Register
0x01E0 2014	SRGR	ASP Sample Rate Generator Register
0x01E0 2024	PCR	ASP Pin Control Register

## 6.19.2 ASP Electrical Data/Timing

### 6.19.2.1 Audio Serial Port (ASP) Timing

**Table 6-88. Timing Requirements for ASP<sup>(1)</sup> (see [Figure 6-67](#))**

NO.				MIN	MAX	UNIT
2	$t_{c(CKRX)}$	Cycle time, CLKR/X	CLKR/X ext	38.5 or $2P^{(2)(3)}$		ns
3	$t_{w(CKRX)}$	Pulse duration, CLKR/X high or CLKR/X low	CLKR/X ext	19.25 or $P^{(2)(3)(4)}$		ns
5	$t_{su(FRH-CKRL)}$	Setup time, external FSR high before CLKR low	CLKR int	11.8		ns
			CLKR ext	1.3		
6	$t_{h(CKRL-FRH)}$	Hold time, external FSR high after CLKR low	CLKR int	6		ns
			CLKR ext	3		
7	$t_{su(DRV-CKRL)}$	Setup time, DR valid before CLKR low	CLKR int	10.7		ns
			CLKR ext	0.9		
8	$t_{h(CKRL-DRV)}$	Hold time, DR valid after CLKR low	CLKR int	3		ns
			CLKR ext	3.1		
10	$t_{su(FXH-CKXL)}$	Setup time, external FSX high before CLKX low	CLKX int	12.2		ns
			CLKX ext	1.4		
11	$t_{h(CKXL-FXH)}$	Hold time, external FSX high after CLKX low	CLKX int	6		ns
			CLKX ext	3		

- (1) CLKRP = CLKXP = FSRP = FSXP = 0. If polarity of any of the signals is inverted, then the timing references of that signal are also inverted.
- (2)  $P = 1/\text{SYSCLK5}$  clock frequency in ns. For example, when running parts at DSP frequency of 594 MHz, use  $P = 10.1$  ns.
- (3) Use whichever value is greater.
- (4) The ASP **does not** require a duty cycle specification, just ensure the minimum pulse duration specification is met.

**Table 6-89. Switching Characteristics Over Recommended Operating Conditions for ASP<sup>(1)(2)</sup>**  
(see [Figure 6-67](#))

NO.	PARAMETER			MIN	MAX	UNIT
2	$t_{c(CKRX)}$	Cycle time, CLKR/X	CLKR/X int	38.5 <sup>(3)</sup>		ns
3	$t_{w(CKRX)}$	Pulse duration, CLKR/X high or CLKR/X low	CLKR/X int	$C - 1$ <sup>(4)</sup>	$C + 1$ <sup>(4)</sup>	ns
4	$t_{d(CKRH-FRV)}$	Delay time, CLKR high to internal FSR valid	CLKR int	-2.1	3	ns
9	$t_{d(CLKH-FXV)}$	Delay time, CLKX high to internal FSX valid	CLKX int	-1.7	3	ns
			CLKX ext	1.7	14.4	
12	$t_{dis(CLKH-DXHZ)}$	Disable time, DX high impedance following last data bit from CLKX high	CLKX int	-3.9	4	ns
			CLKX ext	2.1	13	
13	$t_{d(CLKH-DXV)}$	Delay time, CLKX high to DX valid	CLKX int	$-3.9 + D1$ <sup>(5)</sup>	$4 + D2$ <sup>(5)</sup>	ns
			CLKX ext	$2.1 + D1$ <sup>(5)</sup>	$14.5 + D2$ <sup>(5)</sup>	ns
14	$t_{d(FXH-DXV)}$	Delay time, FSX high to DX valid ONLY applies when in data delay 0 (XDATDLY = 00b) mode	FSX int	$-2.3 + D1$ <sup>(6)</sup>	$4 + D2$ <sup>(6)</sup>	ns
			FSX ext	$1.9 + D1$ <sup>(6)</sup>	$12.1 + D2$ <sup>(6)</sup>	

- (1) CLKRP = CLKXP = FSRP = FSXP = 0. If polarity of any of the signals is inverted, then the timing references of that signal are also inverted.
- (2) Minimum delay times also represent minimum output hold times.
- (3) Minimum CLKR/X cycle times must be met, even when CLKR/X is generated by an internal clock source. Minimum CLKR/X cycle times are based on internal logic speed; the maximum usable speed may be lower due to EDMA limitations and AC timing requirements.
- (4) C = H or L  
 S = sample rate generator input clock = 4P if CLKSM = 1 (P = 1/CPU clock frequency [SYSCLK1])  
 S = sample rate generator input clock = Not Supported if CLKSM = 0 (no CLKS pin on DM6446)  
 H = CLKX high pulse width =  $(CLKGDV/2 + 1) * S$  if CLKGDV is even  
 H =  $(CLKGDV + 1)/2 * S$  if CLKGDV is odd or zero  
 L = CLKX low pulse width =  $(CLKGDV/2) * S$  if CLKGDV is even  
 L =  $(CLKGDV + 1)/2 * S$  if CLKGDV is odd or zero  
 CLKGDV should be set appropriately to ensure the ASP bit rate *does not* exceed the maximum limit [see footnote (3) above].
- (5) Extra delay from CLKX high to DX valid **applies only to the first data bit of a device**, if and only if DXENA = 1 in SPCR.  
 if DXENA = 0, then D1 = D2 = 0  
 if DXENA = 1, then D1 = 4P, D2 = 8P
- (6) Extra delay from FSX high to DX valid **applies only to the first data bit of a device**, if and only if DXENA = 1 in SPCR.  
 if DXENA = 0, then D1 = D2 = 0  
 if DXENA = 1, then D1 = 4P, D2 = 8P

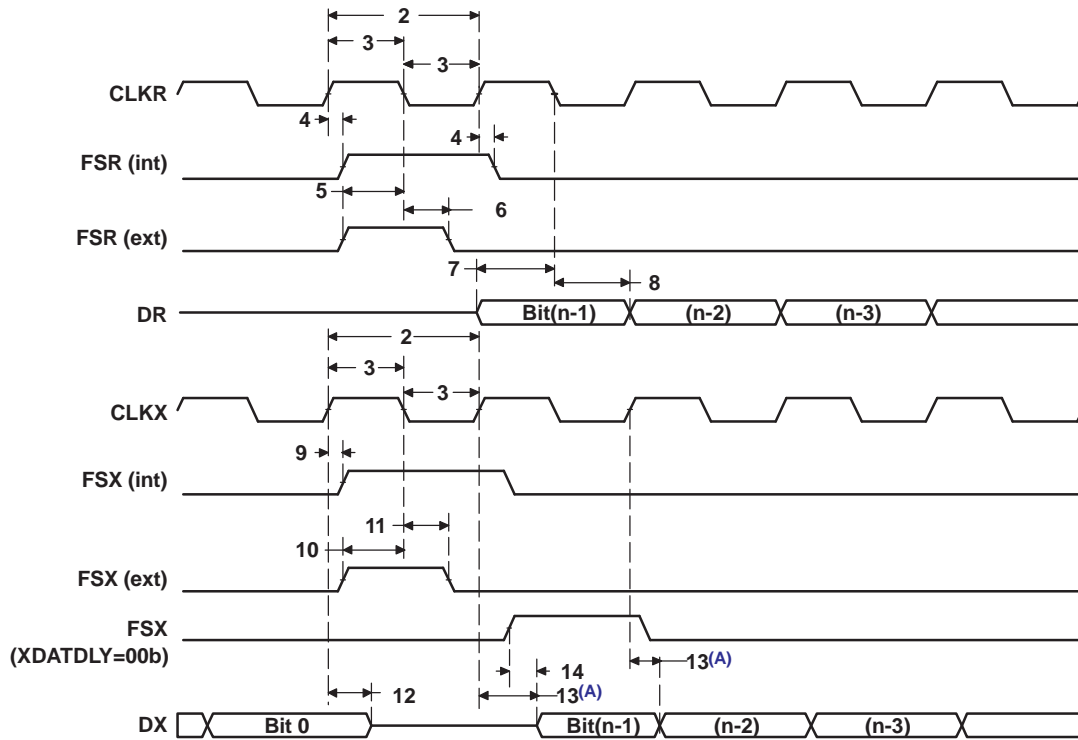

A. Parameter No. 13 applies to the first data bit *only* when XDATDLY ≠ 0.

Figure 6-67. ASP Timing

## 6.20 Ethernet Media Access Controller (EMAC)

The Ethernet Media Access Controller (EMAC) provides an efficient interface between DM6446 and the network. The DM6446 EMAC support both 10Base-T and 100Base-TX, or 10 Mbits/second (Mbps) and 100 Mbps in either half- or full-duplex mode, with hardware flow control and quality of service (QOS) support.

The EMAC controls the flow of packet data from the DM6446 device to the PHY. The MDIO module controls PHY configuration and status monitoring.

Both the EMAC and the MDIO modules interface to the DM6446 device through a custom interface that allows efficient data transmission and reception. This custom interface is referred to as the EMAC control module, and is considered integral to the EMAC/MDIO peripheral. The control module is also used to multiplex and control interrupts.

For the DM6446 Ethernet Media Access Controller (EMAC)/Management Data Input/Output (MDIO) Module Reference Guide which describes the DM6446 EMAC peripheral in detail, see the *Documentation Support* section . For a list of supported registers and register fields, see [Table 6-90](#) [Ethernet MAC (EMAC) Control Registers] and [Table 6-91](#) [EMAC Statistics Registers] in this data manual.

### 6.20.1 EMAC Peripheral Register Description(s)

**Table 6-90. Ethernet MAC (EMAC) Control Registers**

HEX ADDRESS RANGE	ACRONYM	REGISTER NAME
01C8 0000	TXIDVER	Transmit Identification and Version Register
01C8 0004	TXCONTROL	Transmit Control Register
01C8 0008	TXTEARDOWN	Transmit Teardown Register
01C8 0010	RXIDVER	Receive Identification and Version Register
01C8 0014	RXCONTROL	Receive Control Register
01C8 0018	RXTEARDOWN	Receive Teardown Register
01C8 0080	TXINTSTATRAW	Transmit Interrupt Status (Unmasked) Register
01C8 0084	TXINTSTATMASKED	Transmit Interrupt Status (Masked) Register
01C8 0088	TXINTMASKSET	Transmit Interrupt Mask Set Register
01C8 008C	TXINTMASKCLEAR	Transmit Interrupt Mask Clear Register
01C8 0090	MACINVECTOR	MAC Input Vector Register
01C8 00A0	RXINTSTATRAW	Receive Interrupt Status (Unmasked) Register
01C8 00A4	RXINTSTATMASKED	Receive Interrupt Status (Masked) Register
01C8 00A8	RXINTMASKSET	Receive Interrupt Mask Set Register
01C8 00AC	RXINTMASKCLEAR	Receive Interrupt Mask Clear Register
01C8 00B0	MACINTSTATRAW	MAC Interrupt Status (Unmasked) Register
01C8 00B4	MACINTSTATMASKED	MAC Interrupt Status (Masked) Register
01C8 00B8	MACINTMASKSET	MAC Interrupt Mask Set Register
01C8 00BC	MACINTMASKCLEAR	MAC Interrupt Mask Clear Register
01C8 0100	RXMBPENABLE	Receive Multicast/Broadcast/Promiscuous Channel Enable Register
01C8 0104	RXUNICASTSET	Receive Unicast Enable Set Register
01C8 0108	RXUNICASTCLEAR	Receive Unicast Clear Register
01C8 010C	RXMAXLEN	Receive Maximum Length Register
01C8 0110	RXBUFFEROFFSET	Receive Buffer Offset Register
01C8 0114	RXFILTERLOWTHRESH	Receive Filter Low Priority Frame Threshold Register
01C8 0120	RX0FLOWTHRESH	Receive Channel 0 Flow Control Threshold Register
01C8 0124	RX1FLOWTHRESH	Receive Channel 1 Flow Control Threshold Register
01C8 0128	RX2FLOWTHRESH	Receive Channel 2 Flow Control Threshold Register
01C8 012C	RX3FLOWTHRESH	Receive Channel 3 Flow Control Threshold Register

**Table 6-90. Ethernet MAC (EMAC) Control Registers (continued)**

HEX ADDRESS RANGE	ACRONYM	REGISTER NAME
01C8 0130	RX4FLOWTHRESH	Receive Channel 4 Flow Control Threshold Register
01C8 0134	RX5FLOWTHRESH	Receive Channel 5 Flow Control Threshold Register
01C8 0138	RX6FLOWTHRESH	Receive Channel 6 Flow Control Threshold Register
01C8 013C	RX7FLOWTHRESH	Receive Channel 7 Flow Control Threshold Register
01C8 0140	RX0FREEBUFFER	Receive Channel 0 Free Buffer Count Register
01C8 0144	RX1FREEBUFFER	Receive Channel 1 Free Buffer Count Register
01C8 0148	RX2FREEBUFFER	Receive Channel 2 Free Buffer Count Register
01C8 014C	RX3FREEBUFFER	Receive Channel 3 Free Buffer Count Register
01C8 0150	RX4FREEBUFFER	Receive Channel 4 Free Buffer Count Register
01C8 0154	RX5FREEBUFFER	Receive Channel 5 Free Buffer Count Register
01C8 0158	RX6FREEBUFFER	Receive Channel 6 Free Buffer Count Register
01C8 015C	RX7FREEBUFFER	Receive Channel 7 Free Buffer Count Register
01C8 0160	MACCONTROL	MAC Control Register
01C8 0164	MACSTATUS	MAC Status Register
01C8 0168	EMCONTROL	Emulation Control Register
01C8 016C	FIFOCONTROL	FIFO Control Register (Transmit and Receive)
01C8 0170	MACCONFIG	MAC Configuration Register
01C8 0174	SOFTRESET	Soft Reset Register
01C8 01D0	MACSRCADDRLO	MAC Source Address Low Bytes Register (Lower 16-bits)
01C8 01D4	MACSRCADDRHI	MAC Source Address High Bytes Register (Upper 32-bits)
01C8 01D8	MACHASH1	MAC Hash Address Register 1
01C8 01DC	MACHASH2	MAC Hash Address Register 2
01C8 01E0	BOFFTEST	Back Off Test Register
01C8 01E4	TPACETEST	Transmit Pacing Algorithm Test Register
01C8 01E8	RXPAUSE	Receive Pause Timer Register
01C8 01EC	TXPAUSE	Transmit Pause Timer Register
01C8 0200 - 01C8 02FC	(see <a href="#">Table 6-91</a> )	EMAC Statistics Registers
01C8 0500	MACADDRLO	MAC Address Low Bytes Register
01C8 0504	MACADDRHI	MAC Address High Bytes Register
01C8 0508	MACINDEX	MAC Index Register
01C8 0600	TX0HDP	Transmit Channel 0 DMA Head Descriptor Pointer Register
01C8 0604	TX1HDP	Transmit Channel 1 DMA Head Descriptor Pointer Register
01C8 0608	TX2HDP	Transmit Channel 2 DMA Head Descriptor Pointer Register
01C8 060C	TX3HDP	Transmit Channel 3 DMA Head Descriptor Pointer Register
01C8 0610	TX4HDP	Transmit Channel 4 DMA Head Descriptor Pointer Register
01C8 0614	TX5HDP	Transmit Channel 5 DMA Head Descriptor Pointer Register
01C8 0618	TX6HDP	Transmit Channel 6 DMA Head Descriptor Pointer Register
01C8 061C	TX7HDP	Transmit Channel 7 DMA Head Descriptor Pointer Register
01C8 0620	RX0HDP	Receive Channel 0 DMA Head Descriptor Pointer Register
01C8 0624	RX1HDP	Receive Channel 1 DMA Head Descriptor Pointer Register
01C8 0628	RX2HDP	Receive Channel 2 DMA Head Descriptor Pointer Register
01C8 062C	RX3HDP	Receive Channel 3 DMA Head Descriptor Pointer Register
01C8 0630	RX4HDP	Receive Channel 4 DMA Head Descriptor Pointer Register
01C8 0634	RX5HDP	Receive Channel 5 DMA Head Descriptor Pointer Register
01C8 0638	RX6HDP	Receive Channel 6 DMA Head Descriptor Pointer Register
01C8 063C	RX7HDP	Receive Channel 7 DMA Head Descriptor Pointer Register

**Table 6-90. Ethernet MAC (EMAC) Control Registers (continued)**

HEX ADDRESS RANGE	ACRONYM	REGISTER NAME
01C8 0640	TX0CP	Transmit Channel 0 Completion Pointer (Interrupt Acknowledge) Register
01C8 0644	TX1CP	Transmit Channel 1 Completion Pointer (Interrupt Acknowledge) Register
01C8 0648	TX2CP	Transmit Channel 2 Completion Pointer (Interrupt Acknowledge) Register
01C8 064C	TX3CP	Transmit Channel 3 Completion Pointer (Interrupt Acknowledge) Register
01C8 0650	TX4CP	Transmit Channel 4 Completion Pointer (Interrupt Acknowledge) Register
01C8 0654	TX5CP	Transmit Channel 5 Completion Pointer (Interrupt Acknowledge) Register
01C8 0658	TX6CP	Transmit Channel 6 Completion Pointer (Interrupt Acknowledge) Register
01C8 065C	TX7CP	Transmit Channel 7 Completion Pointer (Interrupt Acknowledge) Register
01C8 0660	RX0CP	Receive Channel 0 Completion Pointer (Interrupt Acknowledge) Register
01C8 0664	RX1CP	Receive Channel 1 Completion Pointer (Interrupt Acknowledge) Register
01C8 0668	RX2CP	Receive Channel 2 Completion Pointer (Interrupt Acknowledge) Register
01C8 066C	RX3CP	Receive Channel 3 Completion Pointer (Interrupt Acknowledge) Register
01C8 0670	RX4CP	Receive Channel 4 Completion Pointer (Interrupt Acknowledge) Register
01C8 0674	RX5CP	Receive Channel 5 Completion Pointer (Interrupt Acknowledge) Register
01C8 0678	RX6CP	Receive Channel 6 Completion Pointer (Interrupt Acknowledge) Register
01C8 067C	RX7CP	Receive Channel 7 Completion Pointer (Interrupt Acknowledge) Register



**Table 6-91. EMAC Statistics Registers**

HEX ADDRESS RANGE	ACRONYM	REGISTER NAME
01C8 0200	RXGOODFRAMES	Good Receive Frames Register
01C8 0204	RXBCASTFRAMES	Broadcast Receive Frames Register (Total number of good broadcast frames received)
01C8 0208	RXMCASTFRAMES	Multicast Receive Frames Register (Total number of good multicast frames received)
01C8 020C	RXPAUSEFRAMES	Pause Receive Frames Register
01C8 0210	RXCRCERRORS	Receive CRC Errors Register (Total number of frames received with CRC errors)
01C8 0214	RXALIGNCODEERRORS	Receive Alignment/Code Errors Register (Total number of frames received with alignment/code errors)
01C8 0218	RXOVERSIZED	Receive Oversized Frames Register (Total number of oversized frames received)
01C8 021C	RXJABBER	Receive Jabber Frames Register (Total number of jabber frames received)
01C8 0220	RXUNDERSIZED	Receive Undersized Frames Register (Total number of undersized frames received)
01C8 0224	RXFRAGMENTS	Receive Frame Fragments Register
01C8 0228	RXFILTERED	Filtered Receive Frames Register
01C8 022C	RXQOSFILTERED	Received QOS Filtered Frames Register
01C8 0230	RXOCTETS	Receive Octet Frames Register (Total number of received bytes in good frames)
01C8 0234	TXGOODFRAMES	Good Transmit Frames Register (Total number of good frames transmitted)
01C8 0238	TXBCASTFRAMES	Broadcast Transmit Frames Register
01C8 023C	TXMCASTFRAMES	Multicast Transmit Frames Register
01C8 0240	TXPAUSEFRAMES	Pause Transmit Frames Register
01C8 0244	TXDEFERRED	Deferred Transmit Frames Register
01C8 0248	TXCOLLISION	Transmit Collision Frames Register
01C8 024C	TXSINGLECOLL	Transmit Single Collision Frames Register
01C8 0250	TXMULTICOLL	Transmit Multiple Collision Frames Register
01C8 0254	TXEXCESSIVECOLL	Transmit Excessive Collision Frames Register
01C8 0258	TXLATECOLL	Transmit Late Collision Frames Register
01C8 025C	TXUNDERRUN	Transmit Underrun Error Register
01C8 0260	TXCARRIERSENSE	Transmit Carrier Sense Errors Register
01C8 0264	TXOCTETS	Transmit Octet Frames Register
01C8 0268	FRAME64	Transmit and Receive 64 Octet Frames Register
01C8 026C	FRAME65T127	Transmit and Receive 65 to 127 Octet Frames Register
01C8 0270	FRAME128T255	Transmit and Receive 128 to 255 Octet Frames Register
01C8 0274	FRAME256T511	Transmit and Receive 256 to 511 Octet Frames Register
01C8 0278	FRAME512T1023	Transmit and Receive 512 to 1023 Octet Frames Register
01C8 027C	FRAME1024TUP	Transmit and Receive 1024 to 1518 Octet Frames Register
01C8 0280	NETOCTETS	Network Octet Frames Register
01C8 0284	RXSOFOVERRUNS	Receive FIFO or DMA Start of Frame Overruns Register
01C8 0288	RXMOFOVERRUNS	Receive FIFO or DMA Middle of Frame Overruns Register
01C8 028C	RXDMAOVERRUNS	Receive DMA Start of Frame and Middle of Frame Overruns Register

**Table 6-92. EMAC Control Module Registers**

HEX ADDRESS RANGE	ACRONYM	REGISTER NAME
0x01C8 1004	EWCTL	Interrupt control register
0x01C8 1008	EWINTTCNT	Interrupt timer count

**Table 6-93. EMAC Control Module RAM**

HEX ADDRESS RANGE	ACRONYM	REGISTER NAME
0x01C8 2000 - 0x01C8 3FFF		EMAC Control Module Descriptor Memory

### 6.20.2 EMAC Electrical Data/Timing

Table 6-94. Timing Requirements for MRCLK (see Figure 6-68)

NO.		MIN	MAX	UNIT
1	$t_{c(MRCLK)}$ Cycle time, MRCLK	40		ns
2	$t_{w(MRCLKH)}$ Pulse duration, MRCLK high	14		ns
3	$t_{w(MRCLKL)}$ Pulse duration, MRCLK low	14		ns

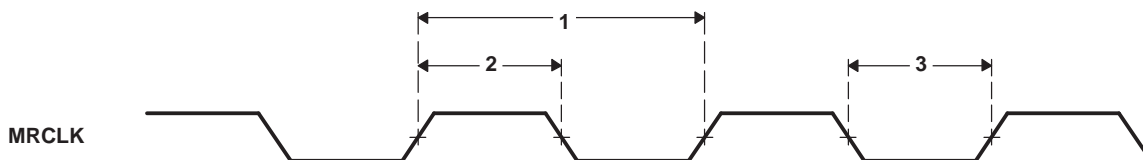

Figure 6-68. MRCLK Timing (EMAC - Receive)

Table 6-95. Timing Requirements for MTCLK (see Figure 6-68)

NO.		MIN	MAX	UNIT
1	$t_{c(MTCLK)}$ Cycle time, MTCLK	40		ns
2	$t_{w(MTCLKH)}$ Pulse duration, MTCLK high	14		ns
3	$t_{w(MTCLKL)}$ Pulse duration, MTCLK low	14		ns

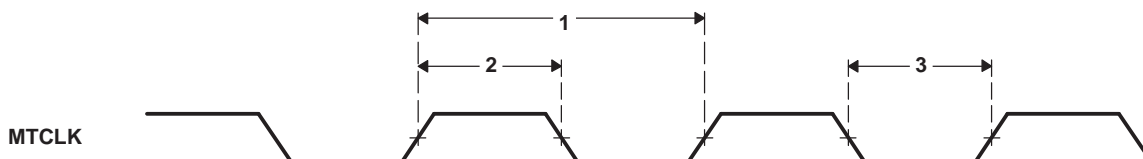

Figure 6-69. MTCLK Timing (EMAC - Transmit)

Table 6-96. Timing Requirements for EMAC MII Receive 10/100 Mbit/s<sup>(1)</sup> (see Figure 6-70)

NO.		MIN	MAX	UNIT
1	$t_{su(MRXD-MRCLKH)}$ Setup time, receive selected signals valid before MRCLK high	8		ns
2	$t_{h(MRCLKH-MRXD)}$ Hold time, receive selected signals valid after MRCLK high	8		ns

(1) Receive selected signals include: MRXD3-MRXD0, MRXDV, and MRXER.

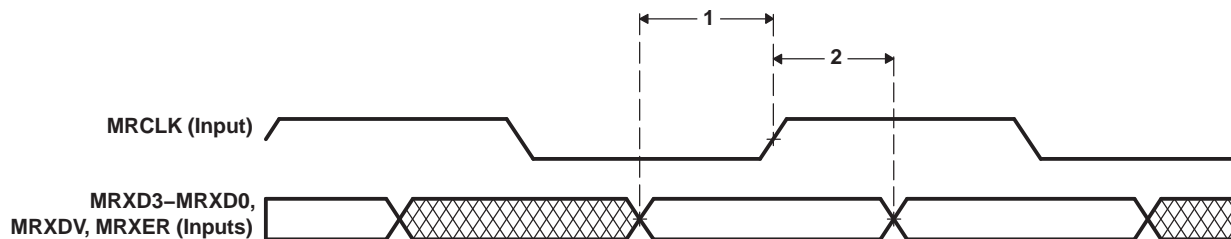

Figure 6-70. EMAC Receive Interface Timing

Table 6-97. Switching Characteristics Over Recommended Operating Conditions for EMAC MII Transmit 10/100 Mbit/s<sup>(1)</sup> (see Figure 6-71)

NO.		MIN	MAX	UNIT
1	$t_{d(MTCLKH-MTXD)}$ Delay time, MTCLK high to transmit selected signals valid	5	25	ns

(1) Transmit selected signals include: MTXD3-MTXD0, and MTXEN.

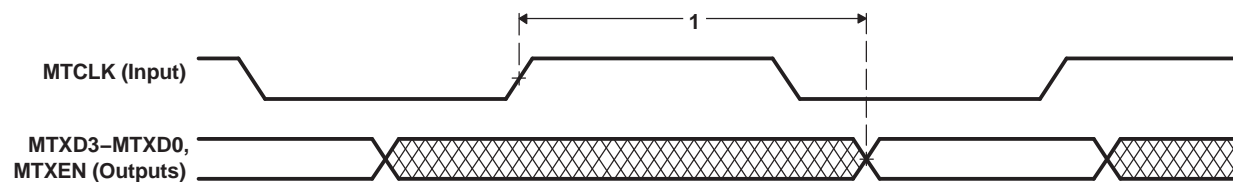

Figure 6-71. EMAC Transmit Interface Timing

## 6.21 Management Data Input/Output (MDIO)

The Management Data Input/Output (MDIO) module continuously polls all 32 MDIO addresses in order to enumerate all PHY devices in the system.

The Management Data Input/Output (MDIO) module implements the 802.3 serial management interface to interrogate and control Ethernet PHY(s) using a shared two-wire bus. Host software uses the MDIO module to configure the auto-negotiation parameters of each PHY attached to the EMAC, retrieve the negotiation results, and configure required parameters in the EMAC module for correct operation. The module is designed to allow almost transparent operation of the MDIO interface, with very little maintenance from the core processor. Only one PHY may be connected at any given time.

For more detailed information on the MDIO peripheral, see the *Documentation Support* section for the Ethernet Media Access Controller (EMAC)/Management Data Input/Output (MDIO) Module Reference Guide. For a list of supported registers and register fields, see [Table 6-98](#) [MDIO Registers] in this data manual.

### 6.21.1 Peripheral Register Description(s)

**Table 6-98. MDIO Registers**

HEX ADDRESS RANGE	ACRONYM	REGISTER NAME
0x01C8 4000	–	Reserved
0x01C8 4004	CONTROL	MDIO Control Register
0x01C8 4008	ALIVE	MDIO PHY Alive Status Register
0x01C8 400C	LINK	MDIO PHY Link Status Register
0x01C8 4010	LINKINTRAW	MDIO Link Status Change Interrupt (Unmasked) Register
0x01C8 4014	LINKINTMASKED	MDIO Link Status Change Interrupt (Masked) Register
0x01C8 4018	–	Reserved
0x01C8 4020	USERINTRAW	MDIO User Command Complete Interrupt (Unmasked) Register
0x01C8 4024	USERINTMASKED	MDIO User Command Complete Interrupt (Masked) Register
0x01C8 4028	USERINTMASKSET	MDIO User Command Complete Interrupt Mask Set Register
0x01C8 402C	USERINTMASKCLEAR	MDIO User Command Complete Interrupt Mask Clear Register
0x01C8 4030 - 0x01C8 407C	–	Reserved
0x01C8 4080	USERACCESS0	MDIO User Access Register 0
0x01C8 4084	USERPHYSEL0	MDIO User PHY Select Register 0
0x01C8 4088	USERACCESS1	MDIO User Access Register 1
0x01C8 408C	USERPHYSEL1	MDIO User PHY Select Register 1
0x01C8 4090 - 0x01C8 47FF	–	Reserved

### 6.21.2 Management Data Input/Output (MDIO) Electrical Data/Timing

Table 6-99. Timing Requirements for MDIO Input (see Figure 6-72 and Figure 6-73)

NO.			MIN	MAX	UNIT
1	$t_{c(MDCLK)}$	Cycle time, MDCLK	400		ns
2	$t_{w(MDCLK)}$	Pulse duration, MDCLK high/low	180		ns
3	$t_t(MDCLK)$	Transition time, MDCLK		5	ns
4	$t_{su(MDIO-MDCLKH)}$	Setup time, MDIO data input valid before MDCLK high	15		ns
5	$t_h(MDCLKH-MDIO)$	Hold time, MDIO data input valid after MDCLK high	0		ns

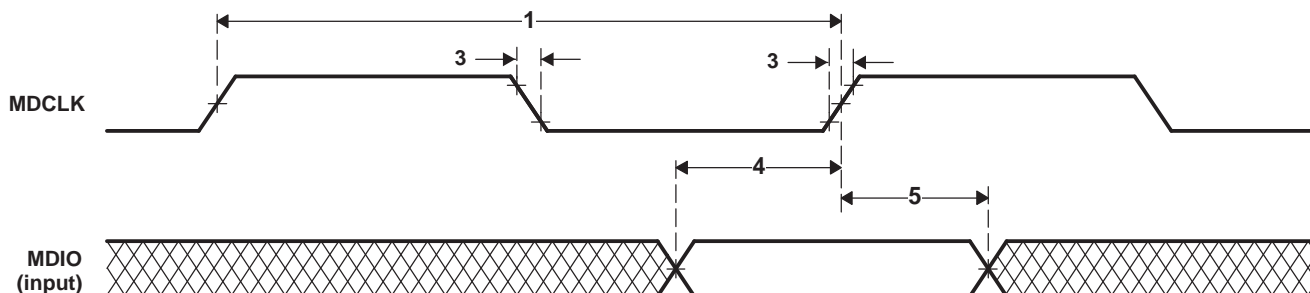

Figure 6-72. MDIO Input Timing

Table 6-100. Switching Characteristics Over Recommended Operating Conditions for MDIO Output (see Figure 6-73)

NO.			MIN	MAX	UNIT
7	$t_{d(MDCLKL-MDIO)}$	Delay time, MDCLK low to MDIO data output valid	-0.6	100	ns

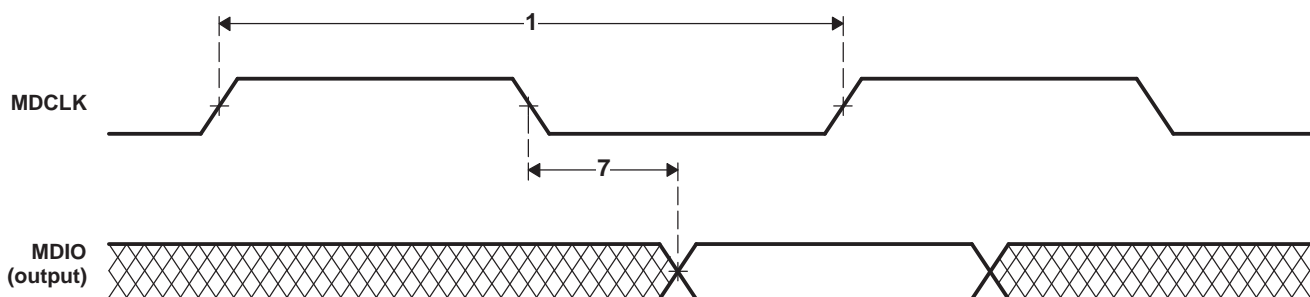

Figure 6-73. MDIO Output Timing

## 6.22 Timer

The DM6446 device has 3 64-bit general-purpose timers which have the following features:

- 64-bit count-up counter
- Timer modes:
  - 64-bit general-purpose timer mode
  - Dual 32-bit general-purpose timer mode (Timer 0 and 1)
  - Watchdog timer mode (Timer 2)
- 2 possible clock sources:
  - Internal clock
  - External clock input via timer input pin TIM\_IN (Timer 0 only)
- 2 operation modes:
  - One-time operation (timer runs for one period then stops)
  - Continuous operation (timer automatically resets after each period)
- Generates interrupts to both the DSP and the ARM CPUs
- Generates sync event to EDMA

For more detailed information, see the *Documentation Support* section for the Timer Reference Guide.

### 6.22.1 Timer Peripheral Register Description(s)

**Table 6-101. Timer 0 Registers**

HEX ADDRESS RANGE	ACRONYM	DESCRIPTION
0x01C2 1400	-	Reserved
0x01C2 1404	EMUMGT_CLKSPD	Timer 0 Emulation Management/Clock Speed Register
0x01C2 1410	TIM12	Timer 0 Counter Register 12
0x01C2 1414	TIM34	Timer 0 Counter Register 34
0x01C2 1418	PRD12	Timer 0 Period Register 12
0x01C2 141C	PRD34	Timer 0 Period Register 34
0x01C2 1420	TCR	Timer 0 Control Register
0x01C2 1424	TGCR	Timer 0 Global Control Register
0x01C2 1428 - 0x01C2 17FF	-	Reserved

**Table 6-102. Timer 1 Registers**

HEX ADDRESS RANGE	ACRONYM	DESCRIPTION
0x01C2 1800	-	Reserved
0x01C2 1804	EMUMGT_CLKSPD	Timer 1 Emulation Management/Clock Speed Register
0x01C2 1810	TIM12	Timer 1 Counter Register 12
0x01C2 1814	TIM34	Timer 1 Counter Register 34
0x01C2 1818	PRD12	Timer 1 Period Register 12
0x01C2 181C	PRD34	Timer 1 Period Register 34
0x01C2 1820	TCR	Timer 1 Control Register
0x01C2 1824	TGCR	Timer 1 Global Control Register
0x01C2 1828 - 0x01C2 1BFF	-	Reserved

Table 6-103. Timer 2 (Watchdog) Registers

HEX ADDRESS RANGE	ACRONYM	DESCRIPTION
0x01C2 1C00	-	Reserved
0x01C2 1C04	EMUMGT_CLKSPD	Timer 2 Emulation Management/Clock Speed Register
0x01C2 1C10	TIM12	Timer 2 Counter Register 12
0x01C2 1C14	TIM34	Timer 2 Counter Register 34
0x01C2 1C18	PRD12	Timer 2 Period Register 12
0x01C2 1C1C	PRD34	Timer 2 Period Register 34
0x01C2 1C20	TCR	Timer 2 Control Register
0x01C2 1C24	TGCR	Timer 2 Global Control Register
0x01C2 1C28	WDTCR	Timer 2 Watchdog Timer Control Register
0x01C2 1C2C - 0x01C2 1FFF	-	Reserved

### 6.2.2.2 Timer Electrical Data/Timing

Table 6-104. Timing Requirements for Timer Input<sup>(1)(2)</sup> (see Figure 6-74)

NO.		MIN	MAX	UNIT
1	$t_{c(TIN)}$ Cycle time, TIM_IN	4P		ns
2	$t_{w(TINPH)}$ Pulse duration, TIM_IN high	0.45C	0.55C	ns
3	$t_{w(TINPL)}$ Pulse duration, TIM_IN low	0.45C	0.55C	ns
4	$t_{t(TIN)}$ Transition time, TIM_IN		0.05C	ns

(1) P = MXI/CLKIN cycle time in ns. For example, when MXI/CLKIN frequency is 27 MHz, use  $P = 37.037$  ns.

(2) C = TIM\_IN cycle time in ns. For example, when TIM\_IN frequency is 27 MHz, use  $C = 37.037$  ns

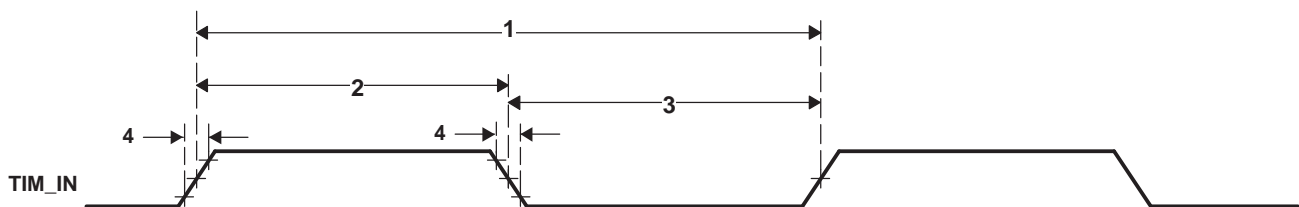

Figure 6-74. Timer Timing



## 6.23 Pulse Width Modulator (PWM)

The 3 DM6446 Pulse Width Modulator (PWM) peripherals support the following features:

- Period counter
- First-phase duration counter
- Repeat count for one-shot operation
- Configurable to operate in either one-shot or continuous mode
- Buffered period and first-phase duration registers
- One-shot operation triggerable by hardware events with programmable edge transitions. (low-to-high or high-to-low).
- One-shot operation generates N+1 periods of waveform, N being the repeat count register value
- Emulation support

The register memory maps for PWM0/1/2 are shown in [Table 6-105](#), [Table 6-106](#), and [Table 6-107](#).

**Table 6-105. PWM0 Register Memory Map**

HEX ADDRESS RANGE	ACRONYM	REGISTER NAME
0x01C2 2000		Reserved
0x01C2 2004	PCR	PWM0 Peripheral Control Register
0x01C2 2008	CFG	PWM0 Configuration Register
0x01C2 200C	START	PWM0 Start Register
0x01C2 2010	RPT	PWM0 Repeat Count Register
0x01C2 2014	PER	PWM0 Period Register
0x01C2 2018	PH1D	PWM0 First-Phase Duration Register
0x01C2 201C - 0x01C2 23FF	-	Reserved

**Table 6-106. PWM1 Register Memory Map**

HEX ADDRESS RANGE	ACRONYM	REGISTER NAME
0x01C2 2400		Reserved
0x01C2 2404	PCR	PWM1 Peripheral Control Register
0x01C2 2408	CFG	PWM1 Configuration Register
0x01C2 240C	START	PWM1 Start Register
0x01C2 2410	RPT	PWM1 Repeat Count Register
0x01C2 2414	PER	PWM1 Period Register
0x01C2 2418	PH1D	PWM1 First-Phase Duration Register
0x01C2 241C -0x01C2 27FF	-	Reserved

**Table 6-107. PWM2 Register Memory Map**

HEX ADDRESS RANGE	ACRONYM	REGISTER NAME
0x01C2 2800		Reserved
0x01C2 2804	PCR	PWM2 Peripheral Control Register
0x01C2 2808	CFG	PWM2 Configuration Register
0x01C2 280C	START	PWM2 Start Register
0x01C2 2810	RPT	PWM2 Repeat Count Register
0x01C2 2814	PER	PWM2 Period Register
0x01C2 2818	PH1D	PWM2 First-Phase Duration Register
0x01C2 281C - 0x01C2 2BFF	-	Reserved

### 6.23.1 PWM0/1/2 Electrical/Timing Data

Table 6-108. Switching Characteristics Over Recommended Operating Conditions for PWM0/1/2 Outputs  
(see Figure 6-75 and Figure 6-76)

NO.	PARAMETER		MIN	MAX	UNIT
1	$t_w(\text{PWMH})$	Pulse duration, PWMx high	37		ns
2	$t_w(\text{PWML})$	Pulse duration, PWMx low	37		ns
3	$t_t(\text{PWM})$	Transition time, PWMx		5	ns
4	$t_d(\text{CCDC-PWMV})$	Delay time, CCDC(VD) trigger event to PWMx valid	2	10	ns

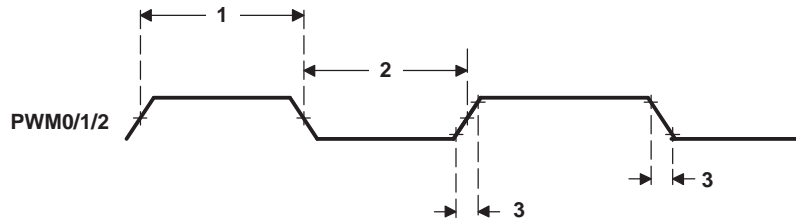

Figure 6-75. PWM Output Timing

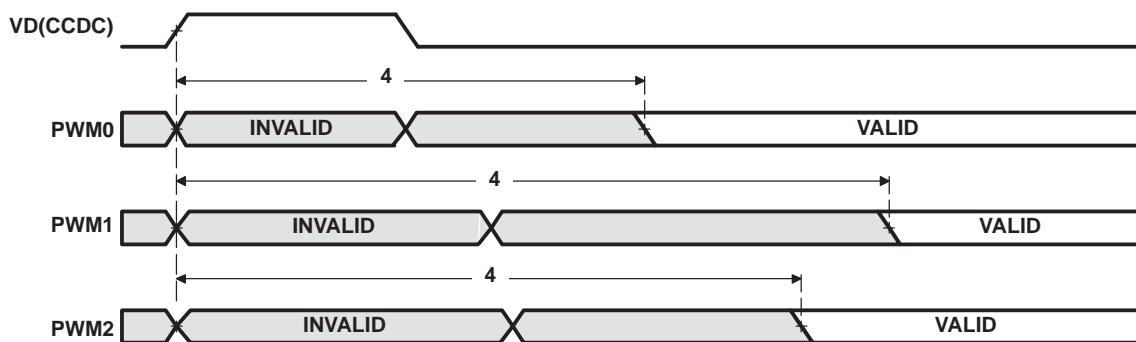

Figure 6-76. PWM Output Delay Timing

## 6.24 VLYNQ

The DM6446 VLYNQ peripheral provides a high speed serial communications interface with the following features.

- Low Pin Count
- Scalable Performance / Support
- Simple Packet Based Transfer Protocol for Memory Mapped Access
  - Write Request / Data Packet
  - Read Request Packet
  - Read Response Data Packet
  - Interrupt Request Packet
- Supports both Symmetric and Asymmetric Operation
  - Tx pins on first device connect to Rx pins on second device and vice versa
  - Data pin widths are automatically detected after reset
  - Request packets, response packets, and flow control information are all multiplexed and sent across the same physical pins
  - Supports both Host/Peripheral and Peer to Peer communication
- Simple Block Code Packet Formatting (8b/10b)
- In Band Flow Control
  - No extra pins needed
  - Allows receiver to momentarily throttle back transmitter when overflow is about to occur
  - Uses built in special code capability of block code to seamlessly interleave flow control information with user data
  - Allows system designer to balance cost of data buffering versus performance
- Multiple outstanding transactions
- Automatic packet formatting optimizations
- Internal loop-back mode

### 6.24.1 VLYNQ Peripheral Register Description(s)

**Table 6-109. VLYNQ Registers**

HEX ADDRESS RANGE	ACRONYM	REGISTER NAME
0x01E0 1000	-	Reserved
0x01E0 1004	CTRL	VLYNQ Local Control Register
0x01E0 1008	STAT	VLYNQ Local Status Register
0x01E0 100C	INTPRI	VLYNQ Local Interrupt Priority Vector Status/Clear Register
0x01E0 1010	INTSTATCLR	VLYNQ Local Unmasked Interrupt Status/Clear Register
0x01E0 1014	INTPENDSET	VLYNQ Local Interrupt Pending/Set Register
0x01E0 1018	INTPTR	VLYNQ Local Interrupt Pointer Register
0x01E0 101C	XAM	VLYNQ Local Transmit Address Map Register
0x01E0 1020	RAMS1	VLYNQ Local Receive Address Map Size 1 Register
0x01E0 1024	RAMO1	VLYNQ Local Receive Address Map Offset 1 Register
0x01E0 1028	RAMS2	VLYNQ Local Receive Address Map Size 2 Register
0x01E0 102C	RAMO2	VLYNQ Local Receive Address Map Offset 2 Register
0x01E0 1030	RAMS3	VLYNQ Local Receive Address Map Size 3 Register
0x01E0 1034	RAMO3	VLYNQ Local Receive Address Map Offset 3 Register
0x01E0 1038	RAMS4	VLYNQ Local Receive Address Map Size 4 Register
0x01E0 103C	RAMO4	VLYNQ Local Receive Address Map Offset 4 Register
0x01E0 1040	CHIPVER	VLYNQ Local Chip Version Register

**Table 6-109. VLYNQ Registers (continued)**

HEX ADDRESS RANGE	ACRONYM	REGISTER NAME
0x01E0 1044	AUTNGO	VLYNQ Local Auto Negotiation Register
0x01E0 1048	-	Reserved
0x01E0 104C	-	Reserved
0x01E0 1050 - 0x01E0 105C	-	Reserved
0x01E0 1060	-	Reserved
0x01E0 1064	-	Reserved
0x01E0 1068 - 0x01E0 107C	-	Reserved <i>for future use</i>
0x01E0 1080	RREVID	VLYNQ Remote Revision Register
0x01E0 1084	RCTRL	VLYNQ Remote Control Register
0x01E0 1088	RSTAT	VLYNQ Remote Status Register
0x01E0 108C	RINTPRI	VLYNQ Remote Interrupt Priority Vector Status/Clear Register
0x01E0 1090	RINTSTATCLR	VLYNQ Remote Unmasked Interrupt Status/Clear Register
0x01E0 1094	RINTPENDSET	VLYNQ Remote Interrupt Pending/Set Register
0x01E0 1098	RINTPTR	VLYNQ Remote Interrupt Pointer Register
0x01E0 109C	RXAM	VLYNQ Remote Transmit Address Map Register
0x01E0 10A0	RRAMS1	VLYNQ Remote Receive Address Map Size 1 Register
0x01E0 10A4	RRAMO1	VLYNQ Remote Receive Address Map Offset 1 Register
0x01E0 10A8	RRAMS2	VLYNQ Remote Receive Address Map Size 2 Register
0x01E0 10AC	RRAMO2	VLYNQ Remote Receive Address Map Offset 2 Register
0x01E0 10B0	RRAMS3	VLYNQ Remote Receive Address Map Size 3 Register
0x01E0 10B4	RRAMO3	VLYNQ Remote Receive Address Map Offset 3 Register
0x01E0 10B8	RRAMS4	VLYNQ Remote Receive Address Map Size 4 Register
0x01E0 10BC	RRAMO4	VLYNQ Remote Receive Address Map Offset 4 Register
0x01E0 10C0	RCHIPVER	VLYNQ Remote Chip Version Register (values on the device_id and device_rev pins of remote VLYNQ)
0x01E0 10C4	RAUTNGO	VLYNQ Remote Auto Negotiation Register
0x01E0 10C8	RMANNGO	VLYNQ Remote Manual Negotiation Register
0x01E0 10CC	RNGOSTAT	VLYNQ Remote Negotiation Status Register
0x01E0 10D0 - 0x01E0 10DC	-	Reserved
0x01E0 10E0	RINTVEC0	VLYNQ Remote Interrupt Vectors 3 - 0 (sourced from vlynq_int_i[3:0] port of remote VLYNQ)
0x01E0 10E4	RINTVEC1	VLYNQ Remote Interrupt Vectors 7 - 4 (sourced from vlynq_int_i[7:4] port of remote VLYNQ)
0x01E0 10E8 - 0x01E0 10FC	-	Reserved <i>for future use</i>
0x01E0 1100 - 0x01E0 1FFF	-	Reserved

### 6.24.2 VLYNQ Electrical Data/Timing

Table 6-110. Timing Requirements for VLYNQ\_CLK for VLYNQ (see Figure 6-77)

NO.		MIN	MAX	UNIT
1	$t_c(\text{VCLK})$ Cycle time, VLYNQ_CLK	10		ns
2	$t_w(\text{VCLKH})$ Pulse duration, VLYNQ_CLK high [CLK External]	3		ns
		4		ns
3	$t_w(\text{VCLKL})$ Pulse duration, VLYNQ_CLK low [CLK External]	3		ns
		4		ns
4	$t_t(\text{VCLK})$ Transition time, VLYNQ_CLK		3	ns

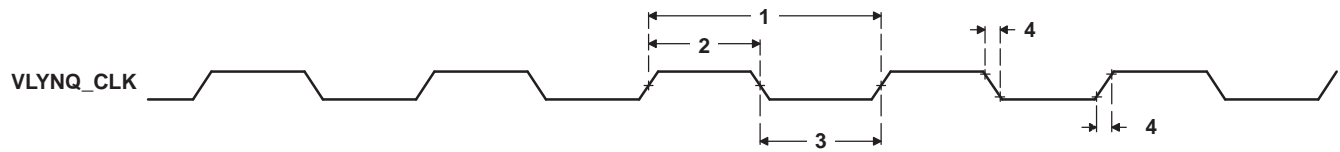

Figure 6-77. VLYNQ\_CLK Timing for VLYNQ

**Table 6-111. Switching Characteristics Over Recommended Operating Conditions for Transmit Data for the VLYNQ Module (see Figure 6-78)**

NO.	PARAMETER	MIN	MAX	UNIT
1	$t_{d(VCLKH-TXD)}$ Delay time, VLYNQ_CLK high to VLYNQ_TXD[3:0] invalid [SLOW Mode]	1		ns
		0.5		ns
2	$t_{d(VCLKH-TXDV)}$ Delay time, VLYNQ_CLK to VLYNQ_TXD[3:0] valid		9.75	ns

**Table 6-112. Timing Requirements for Receive Data for the VLYNQ Module (see Figure 6-78)**

NO.	PARAMETER	MIN	MAX	UNIT
3	$t_{su(RXDV-VCLKH)}$ Setup time, VLYNQ_RXD[3:0] valid before VLYNQ_CLK high	RTM disabled, RTM sample = 3	0.8	ns
		RTM enabled, RXD Flop = 0	2.2	ns
		RTM enabled, RXD Flop = 1	1.9	ns
		RTM enabled, RXD Flop = 2	1.4	ns
		RTM enabled, RXD Flop = 3	0.8	ns
		RTM enabled, RXD Flop = 4	0.4	ns
		RTM enabled, RXD Flop = 5	0.1	ns
		RTM enabled, RXD Flop = 6	-0.2	ns
		RTM enabled, RXD Flop = 7	-0.4	ns
4	$t_{h(VCLKH-RXD)}$ Hold time, VLYNQ_RXD[3:0] valid after VLYNQ_CLK high	RTM disabled, RTM sample = 3	2	ns
		RTM enabled, RXD Flop = 0	0.6	ns
		RTM enabled, RXD Flop = 1	1.0	ns
		RTM enabled, RXD Flop = 2	1.5	ns
		RTM enabled, RXD Flop = 3	2.0	ns
		RTM enabled, RXD Flop = 4	2.5	ns
		RTM enabled, RXD Flop = 5	3.0	ns
		RTM enabled, RXD Flop = 6	3.5	ns
		RTM enabled, RXD Flop = 7	4.0	ns

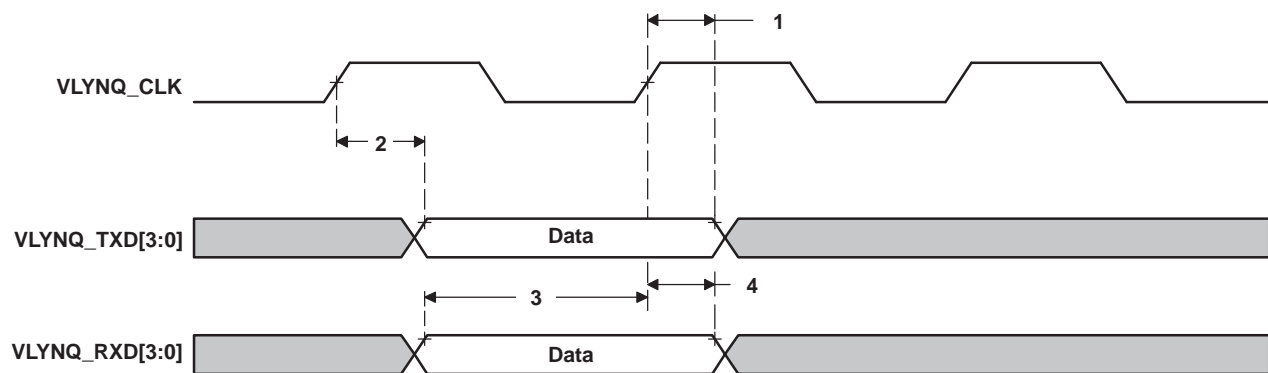

**Figure 6-78. VLYNQ Transmit/Receive Timing**

## 6.25 IEEE 1149.1 JTAG

The JTAG<sup>(1)</sup> interface is used for BSDL testing and emulation of the DM6446 device.

The DM6446 device requires that both  $\overline{\text{TRST}}$  and  $\overline{\text{RESET}}$  be asserted upon power up to be properly initialized. While  $\overline{\text{RESET}}$  initializes the device,  $\overline{\text{TRST}}$  initializes the device's emulation logic. Both resets are required for proper operation.

While both  $\overline{\text{TRST}}$  and  $\overline{\text{RESET}}$  need to be asserted upon power up, only  $\overline{\text{RESET}}$  needs to be released for the device to boot properly.  $\overline{\text{TRST}}$  may be asserted indefinitely for normal operation, keeping the JTAG port interface and device's emulation logic in the reset state.

$\overline{\text{TRST}}$  only needs to be released when it is necessary to use a JTAG controller to debug the device or exercise the device's boundary scan functionality. Note:  $\overline{\text{TRST}}$  is synchronous and **must** be clocked by TCK; otherwise, the boundary scan logic may not respond as expected after  $\overline{\text{TRST}}$  is asserted.

$\overline{\text{RESET}}$  must be released only in order for boundary-scan JTAG to read the variant field of IDCODE correctly. Other boundary-scan instructions work correctly independent of current state of  $\overline{\text{RESET}}$ .

For maximum reliability, DM6446 includes an internal pulldown (IPD) on the  $\overline{\text{TRST}}$  pin to ensure that  $\overline{\text{TRST}}$  will always be asserted upon power up and the device's internal emulation logic will always be properly initialized.

JTAG controllers from Texas Instruments actively drive  $\overline{\text{TRST}}$  high. However, some third-party JTAG controllers may not drive  $\overline{\text{TRST}}$  high but expect the use of a pullup resistor on  $\overline{\text{TRST}}$ .

When using this type of JTAG controller, assert  $\overline{\text{TRST}}$  to initialize the device after powerup and externally drive  $\overline{\text{TRST}}$  high before attempting any emulation or boundary scan operations.

### 6.25.1 JTAG Peripheral Register Description(s) – JTAG ID Register

(1) IEEE Standard 1149.1-1990 Standard-Test-Access Port and Boundary Scan Architecture.

Table 6-113. JTAG ID Register

HEX ADDRESS RANGE	ACRONYM	REGISTER NAME	COMMENTS
0x01C4 0028	JTAGID	JTAG Identification Register	Read-only. Provides 32-bit JTAG ID of the device.

The JTAG ID register is a read-only register that identifies to the customer the JTAG/Device ID. For the DM6446 device, the JTAG ID register resides at address location 0x01C4 0028. The register hex value for DM6446 is: **0x0B70 002F for silicon revisions 1.3 and earlier, and 0x1B70 002F for silicon revision 2.1**. For the actual register bit names and their associated bit field descriptions, see [Figure 6-79](#) and [Table 6-114](#).

31-28	27-12	11-1	0
VARIANT (4-Bit) <sup>(A)</sup>	PART NUMBER (16-Bit)	MANUFACTURER (11-Bit)	LSB
R-000x	R-1011 0111 0000 0000	R-0000 0010 111	R-1

LEGEND: R = Read, W = Write, n = value at reset

(A) For silicon revisions 1.3 and earlier, VARIANT = 0000. For silicon revision 2.1, VARIANT = 0001.

Figure 6-79. JTAG ID Register Description - DM6446 Register Value - 0xB70 002F

Table 6-114. JTAG ID Register Selection Bit Descriptions

BIT	NAME	DESCRIPTION
31:28	VARIANT	Variant (4-Bit) value. DM6446 value: 0000 for silicon revisions 1.3 and earlier, and 0001 for silicon revision 2.1.
27:12	PART NUMBER	Part Number (16-Bit) value. DM6446 value: 1011 0111 0000 0000.
11-1	MANUFACTURER	Manufacturer (11-Bit) value. DM6446 value: 0000 0010 111.
0	LSB	LSB. This bit is read as a "1" for DM6446.

### 6.25.2 JTAG Test-Port Electrical Data/Timing

Table 6-115. Timing Requirements for JTAG Test Port (see Figure 6-80)

NO.	PARAMETER	MIN	MAX	UNIT
1	$t_{c(TCK)}$ Cycle time, TCK	20		ns
2	$t_{w(TCKH)}$ Pulse duration, TCK high	8		ns
3	$t_{w(TCKL)}$ Pulse duration, TCK low	8		ns
4	$t_{c(RTCK)}$ Cycle time, RTCK	20		ns
5	$t_{w(RTCKH)}$ Pulse duration, RTCK high	10		ns
6	$t_{w(RTCKL)}$ Pulse duration, RTCK low	10		ns
7	$t_{su(TDIV-RTCKH)}$ Setup time, TDI/TMS valid before RTCK high	10		ns
8	$t_{h(RTCKH-TDIV)}$ Hold time, TDI/TMS valid after RTCK high	1		ns

Table 6-116. Switching Characteristics Over Recommended Operating Conditions for JTAG Test Port (see Figure 6-80)

NO.	PARAMETER	MIN	MAX	UNIT
9	$t_{d(RTCKL-TDOV)}$ Delay time, RTCK low to TDO valid		15	ns

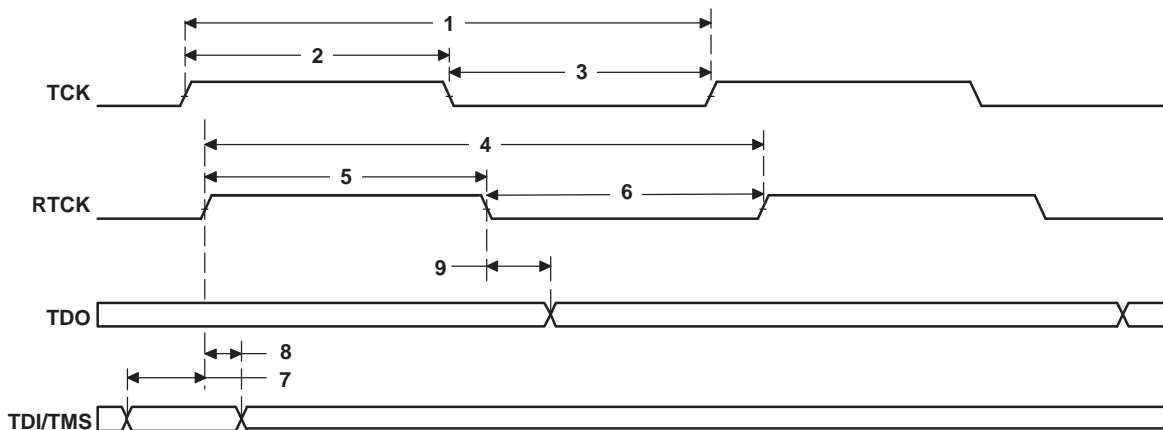

Figure 6-80. JTAG Test-Port Timing



## 7 Mechanical Packaging and Orderable Information

The following table(s) show the thermal resistance characteristics for the PBGA–ZWT mechanical package.

### 7.1 Thermal Data for ZWT

**Table 7-1. Thermal Resistance Characteristics (PBGA Package) [ZWT]**

NO.			= C/W <sup>(1)</sup>	AIR FLOW (m/s) <sup>(2)</sup>
1	R $\theta$ <sub>JC</sub>	Junction-to-case	6.54	N/A
2	R $\theta$ <sub>JB</sub>	Junction-to-board	15.62	N/A
3	R $\theta$ <sub>JA</sub>	Junction-to-free air	29.75	0.00
4			26.78	1.0
5			26.20	2.00
6			25.80	3.00
7			0.11	0.00
8	Psi <sub>JT</sub>	Junction-to-package top	0.15	1.0
9			0.16	2.00
10			0.16	3.00
11			14.79	0.00
12	Psi <sub>JB</sub>	Junction-to-board	14.66	1.0
13			14.66	2.00
14			14.66	3.00

(1) These measurements were conducted in a JEDEC defined 1S2P system and will change based on environment as well as application. For more information, see these EIA/JEDEC standards – EIA/JESD51-2, *Integrated Circuits Thermal Test Method Environment Conditions - Natural Convection (Still Air)* and JESD51-7, *High Effective Thermal Conductivity Test Board for Leaded Surface Mount Packages*.

(2) m/s = meters per second

#### 7.1.1 Packaging Information

The following packaging information and addendum reflect the most current data available for the designated device(s). This data is subject to change without notice and without revision of this document.

**PACKAGING INFORMATION**

Orderable Device	Status (1)	Package Type	Package Drawing	Pins	Package Qty	Eco Plan (2)	Lead finish/ Ball material (6)	MSL Peak Temp (3)	Op Temp (°C)	Device Marking (4/5)	Samples
SM320DM6446AZWTA	ACTIVE	NFBGA	ZWT	361	90	RoHS & Green	SNAGCU	Level-3-260C-168 HR	-40 to 105	SMDM6446AZWTA DAVINCI	Samples

(1) The marketing status values are defined as follows:

**ACTIVE:** Product device recommended for new designs.

**LIFEBUY:** TI has announced that the device will be discontinued, and a lifetime-buy period is in effect.

**NRND:** Not recommended for new designs. Device is in production to support existing customers, but TI does not recommend using this part in a new design.

**PREVIEW:** Device has been announced but is not in production. Samples may or may not be available.

**OBSOLETE:** TI has discontinued the production of the device.

(2) **RoHS:** TI defines "RoHS" to mean semiconductor products that are compliant with the current EU RoHS requirements for all 10 RoHS substances, including the requirement that RoHS substance do not exceed 0.1% by weight in homogeneous materials. Where designed to be soldered at high temperatures, "RoHS" products are suitable for use in specified lead-free processes. TI may reference these types of products as "Pb-Free".

**RoHS Exempt:** TI defines "RoHS Exempt" to mean products that contain lead but are compliant with EU RoHS pursuant to a specific EU RoHS exemption.

**Green:** TI defines "Green" to mean the content of Chlorine (Cl) and Bromine (Br) based flame retardants meet JS709B low halogen requirements of <=100ppm threshold. Antimony trioxide based flame retardants must also meet the <=1000ppm threshold requirement.

(3) MSL, Peak Temp. - The Moisture Sensitivity Level rating according to the JEDEC industry standard classifications, and peak solder temperature.

(4) There may be additional marking, which relates to the logo, the lot trace code information, or the environmental category on the device.

(5) Multiple Device Markings will be inside parentheses. Only one Device Marking contained in parentheses and separated by a "~" will appear on a device. If a line is indented then it is a continuation of the previous line and the two combined represent the entire Device Marking for that device.

(6) Lead finish/Ball material - Orderable Devices may have multiple material finish options. Finish options are separated by a vertical ruled line. Lead finish/Ball material values may wrap to two lines if the finish value exceeds the maximum column width.

**Important Information and Disclaimer:**The information provided on this page represents TI's knowledge and belief as of the date that it is provided. TI bases its knowledge and belief on information provided by third parties, and makes no representation or warranty as to the accuracy of such information. Efforts are underway to better integrate information from third parties. TI has taken and continues to take reasonable steps to provide representative and accurate information but may not have conducted destructive testing or chemical analysis on incoming materials and chemicals. TI and TI suppliers consider certain information to be proprietary, and thus CAS numbers and other limited information may not be available for release.

In no event shall TI's liability arising out of such information exceed the total purchase price of the TI part(s) at issue in this document sold by TI to Customer on an annual basis.

**TRAY**

Chamfer on Tray corner indicates Pin 1 orientation of packed units.

\*All dimensions are nominal

Device	Package Name	Package Type	Pins	SPQ	Unit array matrix	Max temperature (°C)	L (mm)	W (mm)	K0 (µm)	P1 (mm)	CL (mm)	CW (mm)
SM320DM6446AZWTA	ZWT	NFBGA	361	90	6 X 15	150	315	135.9	7620	20	17.5	15.45



## IMPORTANT NOTICE AND DISCLAIMER

TI PROVIDES TECHNICAL AND RELIABILITY DATA (INCLUDING DATA SHEETS), DESIGN RESOURCES (INCLUDING REFERENCE DESIGNS), APPLICATION OR OTHER DESIGN ADVICE, WEB TOOLS, SAFETY INFORMATION, AND OTHER RESOURCES "AS IS" AND WITH ALL FAULTS, AND DISCLAIMS ALL WARRANTIES, EXPRESS AND IMPLIED, INCLUDING WITHOUT LIMITATION ANY IMPLIED WARRANTIES OF MERCHANTABILITY, FITNESS FOR A PARTICULAR PURPOSE OR NON-INFRINGEMENT OF THIRD PARTY INTELLECTUAL PROPERTY RIGHTS.

These resources are intended for skilled developers designing with TI products. You are solely responsible for (1) selecting the appropriate TI products for your application, (2) designing, validating and testing your application, and (3) ensuring your application meets applicable standards, and any other safety, security, regulatory or other requirements.

These resources are subject to change without notice. TI grants you permission to use these resources only for development of an application that uses the TI products described in the resource. Other reproduction and display of these resources is prohibited. No license is granted to any other TI intellectual property right or to any third party intellectual property right. TI disclaims responsibility for, and you will fully indemnify TI and its representatives against, any claims, damages, costs, losses, and liabilities arising out of your use of these resources.

TI's products are provided subject to [TI's Terms of Sale](#) or other applicable terms available either on [ti.com](https://www.ti.com) or provided in conjunction with such TI products. TI's provision of these resources does not expand or otherwise alter TI's applicable warranties or warranty disclaimers for TI products.

TI objects to and rejects any additional or different terms you may have proposed.

Mailing Address: Texas Instruments, Post Office Box 655303, Dallas, Texas 75265  
Copyright © 2024, Texas Instruments Incorporated