

# TPS51216-EP 具有同步降压控制器、2A LDO 和缓冲基准的完整 DDR2、DDR3 和 DDR3L 存储器电源解决方案

## 1 特性

- 同步降压控制器 (VDDQ)
  - 转换电压范围：3 至 28 V
  - 输出电压范围：0.7 至 1.8 V
  - 0.8%  $V_{REF}$  精度
  - D-CAP™ 模式，可实现快速瞬态响应
  - 可选 300kHz/400kHz 开关频率
  - 自动跳过功能优化了轻负载和重载时的效率
  - 支持 S4/S5 状态下的软关闭
  - OCL/OVP/UVLP/UVLO 保护
  - 电源正常输出
- 2A LDO (VTT)、缓冲基准 (VTTREF)
  - 2A (峰值) 灌电流和拉电流
  - 只需 10  $\mu$ F 陶瓷输出电容
  - 经缓冲的低噪声 10mA VTTREF 输出
  - 0.8% VTTREF，20mV VTT 精度
  - 在 S3 下支持高阻抗，在 S4/S5 下支持软关闭
- 热关断
- 20 引脚 3mm  $\times$  3mm WQFN 封装
- 支持国防、航天和医疗应用
  - 受控基线
  - 一个组装/测试基地
  - 一个制造基地
  - 支持军用 (-55°C 至 125°C) 温度范围，<sup>1</sup>
  - 延长了产品生命周期
  - 延长了产品变更通知
  - 产品可追溯性

## 2 应用

- DDR2/DDR3/DDR3L 存储器电源
- SSTL\_18、SSTL\_15、SSTL\_135 和 HSTL 终端

## 3 说明

TPS51216-EP 以最少总成本和最小空间为 DDR2、DDR3 和 DDR3L 存储器系统提供完整的电源。它将同步降压稳压器控制器 (VDDQ) 与 2A 灌电流/拉电流跟踪 LDO (VTT) 和缓冲低噪声基准 (VTTREF) 相集成。TPS51216-EP 采用 D-CAP™ 模式与 300kHz/400kHz 频率相结合，以实现易用性和快速瞬态响应。VTTREF 跟踪 VDDQ/2 的精度优于 0.8%。能够提供 2A 灌电流/拉电流峰值电流功能的 VTT 只需 10  $\mu$ F 的陶瓷电容器。此外，还提供专用的 LDO 电源输入。

TPS51216-EP 提供丰富、实用的功能以及出色的电源性能。它支持灵活功率级控制，将 VTT 置于高阻抗状态 (处于 S3) 并在 S4/S5 状态下对 VDDQ、VTT 和 VTTREF 进行放电 (软关闭)。

### 器件信息

器件型号 <sup>(1)</sup>	封装	封装尺寸 (标称值)
TPS51216-EP	WQFN (20)	3.00mm $\times$ 3.00mm

(1) 如需了解所有可用封装，请参阅产品说明书末尾的可订购产品附录。

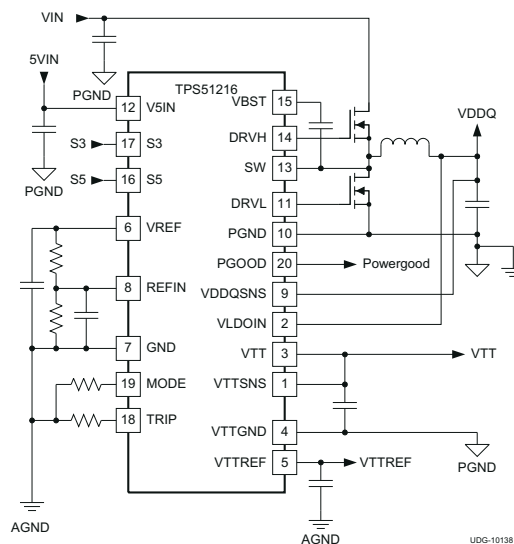

应用示意图

<sup>1</sup> 提供额外的温度范围 - 请联系工厂



## Table of Contents

<b>1 特性</b> .....	<b>1</b>	8.4 Device Functional Modes.....	<b>19</b>
<b>2 应用</b> .....	<b>1</b>	<b>9 Application and Implementation</b> .....	<b>20</b>
<b>3 说明</b> .....	<b>1</b>	9.1 Application Information.....	<b>20</b>
<b>4 Revision History</b> .....	<b>2</b>	9.2 Typical Application.....	<b>23</b>
<b>5 说明 (续)</b> .....	<b>3</b>	<b>10 Power Supply Recommendations</b> .....	<b>26</b>
<b>6 Pin Configuration and Functions</b> .....	<b>4</b>	<b>11 Layout</b> .....	<b>27</b>
<b>7 Specifications</b> .....	<b>5</b>	11.1 Layout Guidelines.....	<b>27</b>
7.1 Absolute Maximum Ratings.....	<b>5</b>	11.2 Layout Example.....	<b>28</b>
7.2 ESD Ratings.....	<b>5</b>	<b>12 Device and Documentation Support</b> .....	<b>29</b>
7.3 Recommended Operating Conditions.....	<b>6</b>	12.1 接收文档更新通知.....	<b>29</b>
7.4 Thermal Information.....	<b>6</b>	12.2 支持资源.....	<b>29</b>
7.5 Electrical Characteristics.....	<b>7</b>	12.3 Trademarks.....	<b>29</b>
7.6 Typical Characteristics.....	<b>11</b>	12.4 Electrostatic Discharge Caution.....	<b>29</b>
<b>8 Detailed Description</b> .....	<b>16</b>	12.5 术语表.....	<b>29</b>
8.1 Overview.....	<b>16</b>	<b>13 Mechanical, Packaging, and Orderable Information</b> .....	<b>29</b>
8.2 Functional Block Diagram.....	<b>16</b>		
8.3 Feature Description.....	<b>16</b>		

## 4 Revision History

Changes from Revision * (November 2015) to Revision A (July 2022)	Page
• 更新了整个文档中的表格、图和交叉引用的编号格式.....	<b>1</b>
• Updated resistor numbers in Equation 7 to match description.....	<b>24</b>

## 5 说明 (续)

它还提供具有低侧 MOSFET  $R_{DS(on)}$  检测功能的可编程 OCL、OVP/UVLP/UVLO 以及热关断保护。

TPS51216-EP 采用 20 引脚 3mm × 3mm WQFN 封装，额定结温为 -55°C 至 125°C。

## 6 Pin Configuration and Functions



图 6-1. RUK Package 20-Pin WQFN Top View

表 6-1. Pin Functions

PIN		I/O	DESCRIPTION
NAME	NO.		
DRVH	14	O	High-side MOSFET gate driver output.
DRVL	11	O	Low-side MOSFET gate driver output.
GND	7	—	Signal ground.
MODE	19	I	Connect resistor to GND to configure switching frequency and discharge mode. (See 表 8-2.)
PGND	10	—	Gate driver power ground. $R_{DS(on)}$ current sensing input (+).
PGOOD	20	O	Powergood signal open drain output. PGOOD goes high when VDDQ output voltage is within the target range.
REFIN	8	I	Reference input for VDDQ. Connect to the midpoint of a resistor divider from VREF to GND. Add a capacitor for stable operation.
SW	13	I/O	High-side MOSFET gate driver return. $R_{DS(on)}$ current sensing input (-).
S3	17	I	S3 signal input. (See 表 8-1.)
S5	16	I	S5 signal input. (See 表 8-1.)
TRIP	18	I	Connect resistor to GND to set OCL at $V_{TRIP} / 8$ . Output 10- $\mu$ A current at room temperature, $T_C = 4700$ ppm/ $^{\circ}$ C.
VBST	15	I	High-side MOSFET gate driver bootstrap voltage input. Connect a capacitor from the VBST pin to the SW pin.
VDDQSNS	9	I	VDDQ output voltage feedback. Reference input for VTTREF. Also serves as power supply for VTTREF.
VLDOIN	2	I	Power supply input for VTT LDO. Connect VDDQ in typical application.
VREF	6	O	1.8-V reference output.
VTT	3	O	VTT 2-A LDO output. Need to connect 10 $\mu$ F or larger capacitance for stability.
VTTGND	4	—	Power ground for VTT LDO.
VTTREF	5	O	Buffered VTT reference output. Need to connect 0.22 $\mu$ F or larger capacitance for stability.
VTTSENS	1	I	VTT output voltage feedback.
V5IN	12	I	5-V power supply input for internal circuits and MOSFET gate drivers.
Thermal pad	—	—	Connect to GND

## 7 Specifications

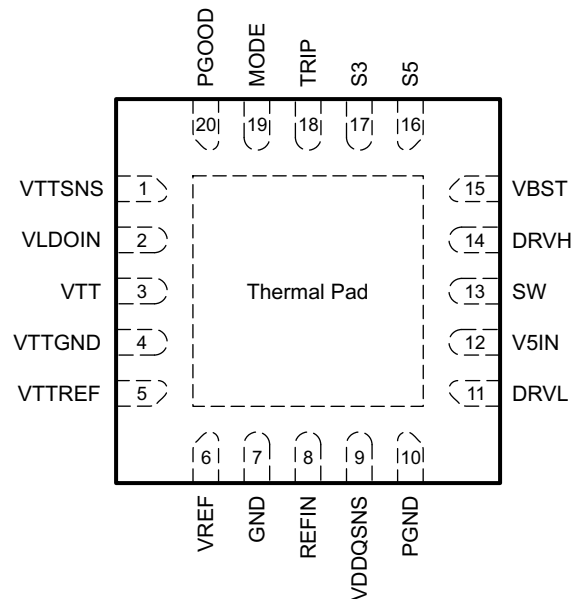
### 7.1 Absolute Maximum Ratings

over operating free-air temperature range (unless otherwise noted)<sup>(1)</sup>

		MIN	MAX	UNIT
Input voltage <sup>(2)</sup>	VBST	- 0.3	36	V
	VBST <sup>(3)</sup>	- 0.3	6	
	SW	- 5	30	
	VLDOIN, VDDQSNS, REFIN	- 0.3	3.6	
	VTTSNS	- 0.3	3.6	
	PGND, VTTGND	- 0.3	0.3	
	V5IN, S3, S5, TRIP, MODE	- 0.3	6	
Output voltage <sup>(2)</sup>	DRVH	- 5	36	V
	DRVH <sup>(3)</sup>	- 0.3	6	
	DRVH <sup>(3)</sup> (duty cycle < 1%)	- 2.5	6	
	VTTREF, VREF	- 0.3	3.6	
	VTT	- 0.3	3.6	
	DRVL	- 0.3	6	
	DRVL (duty cycle < 1%)	- 2.5	6	
	PGOOD	- 0.3	6	
Junction temperature, T <sub>J</sub>		- 55	135	°C
Storage temperature, T <sub>stg</sub>		- 55	150	°C

- (1) Stresses beyond those listed under *Absolute Maximum Ratings* may cause permanent damage to the device. These are stress ratings only, which do not imply functional operation of the device at these or any other conditions beyond those indicated under *Recommended Operating Conditions*. Exposure to absolute-maximum-rated conditions for extended periods may affect device reliability.
- (2) All voltage values are with respect to the network ground terminal unless otherwise noted.
- (3) Voltage values are with respect to the SW terminal.

### 7.2 ESD Ratings

		VALUE	UNIT
V <sub>(ESD)</sub> Electrostatic discharge	Human-body model (HBM), per ANSI/ESDA/JEDEC JS-001 <sup>(1)</sup>	±2000	V
	Charged-device model (CDM), per JEDEC specification JESD22-C101 <sup>(2)</sup>	±500	

- (1) JEDEC document JEP155 states that 500-V HBM allows safe manufacturing with a standard ESD control process.
- (2) JEDEC document JEP157 states that 250-V CDM allows safe manufacturing with a standard ESD control process.

### 7.3 Recommended Operating Conditions

		MIN	NOM	MAX	UNIT
Supply voltage	V5IN	4.5		5.5	V
Input voltage range	VBST	- 0.1		33.5	V
	VBST <sup>(2)</sup>	- 0.1		5.5	
	SW	-3		28	
	SW <sup>(1)</sup>	- 4.5		28	
	VLDOIN, VDDQSNS, REFIN	- 0.1		3.5	
	VTTSENS	- 0.1		3.5	
	PGND, VTTGND	- 0.1		0.1	
	S3, S5, TRIP, MODE	- 0.1		5.5	
Output voltage range	DRVH	- 3		33.5	V
	DRVH <sup>(2)</sup>	- 0.1		5.5	
	DRVH <sup>(1)</sup>	- 4.5		33.5	
	VTTREF, VREF	- 0.1		3.5	
	VTT	- 0.1		3.5	
	DRVL	- 0.1		5.5	
	PGOOD	- 0.1		5.5	
T <sub>J</sub>	Operating junction temperature	- 55		125	°C

(1) This voltage should be applied for less than 30% of the repetitive period.

(2) Voltage values are with respect to the SW terminal.

### 7.4 Thermal Information

THERMAL METRIC <sup>(1)</sup>		TPS51216-EP	
		RUK (WQFN)	
		20 PINS	
			UNIT
R <sub>θJA</sub>	Junction-to-ambient thermal resistance	94.1	°C/W
R <sub>θJC(top)</sub>	Junction-to-case (top) thermal resistance	58.1	°C/W
R <sub>θJB</sub>	Junction-to-board thermal resistance	64.3	°C/W
ψ <sub>JT</sub>	Junction-to-top characterization parameter	31.8	°C/W
ψ <sub>JB</sub>	Junction-to-board characterization parameter	58.0	°C/W
R <sub>θJC(bot)</sub>	Junction-to-case (bottom) thermal resistance	5.9	°C/W

(1) For more information about traditional and new thermal metrics, see the *Semiconductor and IC Package Thermal Metrics* application report, [SPRA953](#).

## 7.5 Electrical Characteristics

$T_J = -55^{\circ}\text{C}$  to  $125^{\circ}\text{C}$ ,  $V_{V5IN} = 5\text{ V}$ , VLDOIN is connected to VDDQ output,  $V_{\text{MODE}} = 0\text{ V}$ ,  $V_{S3} = V_{S5} = 5\text{ V}$  (unless otherwise noted)

PARAMETER		TEST CONDITION	MIN	TYP	MAX	UNIT
<b>SUPPLY CURRENT</b>						
$I_{V5IN(S0)}$	V5IN supply current, in S0	$T_J = 25^{\circ}\text{C}$ , No load, $V_{S3} = V_{S5} = 5\text{ V}$		590		$\mu\text{A}$
$I_{V5IN(S3)}$	V5IN supply current, in S3	$T_J = 25^{\circ}\text{C}$ , No load, $V_{S3} = 0\text{ V}$ , $V_{S5} = 5\text{ V}$		500		$\mu\text{A}$
$I_{V5INSDN}$	V5IN shutdown current	$T_J = 25^{\circ}\text{C}$ , No load, $V_{S3} = V_{S5} = 0\text{ V}$			1	$\mu\text{A}$
$I_{VLDOIN(S0)}$	VLDOIN supply current, in S0	$T_J = 25^{\circ}\text{C}$ , No load, $V_{S3} = V_{S5} = 5\text{ V}$			5	$\mu\text{A}$
$I_{VLDOIN(S3)}$	VLDOIN supply current, in S3	$T_J = 25^{\circ}\text{C}$ , No load, $V_{S3} = 0\text{ V}$ , $V_{S5} = 5\text{ V}$			5	$\mu\text{A}$
$I_{VLDOINSDN}$	VLDOIN shutdown current	$T_J = 25^{\circ}\text{C}$ , No load, $V_{S3} = V_{S5} = 0\text{ V}$			5	$\mu\text{A}$
<b>VREF OUTPUT</b>						
$V_{VREF}$	Output voltage	$I_{VREF} = 30\ \mu\text{A}$ , $T_J = 25^{\circ}\text{C}$		1.8000		V
		$0\ \mu\text{A} \leq I_{VREF} < 300\ \mu\text{A}$ , $T_J = -55^{\circ}\text{C}$ to $125^{\circ}\text{C}$	1.7820		1.8180	
$I_{VREFOCL}$	Current limit	$V_{VREF} = 1.7\text{ V}$	0.4	0.8		mA
<b>VTTREF OUTPUT</b>						
$V_{VTTREF}$	Output voltage			$V_{VDDQSNS}/2$		V
$V_{VTTREF}$	Output voltage tolerance to $V_{VDDQ}$	$ I_{VTTREF}  < 100\ \mu\text{A}$ , $1.2\text{ V} \leq V_{VDDQSNS} \leq 1.8\text{ V}$	49.2%		50.8%	
		$ I_{VTTREF}  < 10\text{ mA}$ , $1.2\text{ V} \leq V_{VDDQSNS} \leq 1.8\text{ V}$	49%		51%	
$I_{VTTREFOCLSRC}$	Source current limit	$V_{VDDQSNS} = 1.8\text{ V}$ , $V_{VTTREF} = 0\text{ V}$	10	18		mA
$I_{VTTREFOCLSNK}$	Sink current limit	$V_{VDDQSNS} = 1.8\text{ V}$ , $V_{VTTREF} = 1.8\text{ V}$	10	17		mA
$I_{VTTREFDIS}$	VTTREF discharge current	$T_J = 25^{\circ}\text{C}$ , $V_{S3} = V_{S5} = 0\text{ V}$ , $V_{VTTREF} = 0.5\text{ V}$	0.8	1.3		mA
<b>VTT OUTPUT</b>						
$V_{VTT}$	Output voltage			$V_{VTTREF}$		V
$V_{VTTTOL}$	Output voltage tolerance to VTTREF	$ I_{VTT}  \leq 10\text{ mA}$ , $1.2\text{ V} \leq V_{VDDQSNS} \leq 1.8\text{ V}$ , $I_{VTTREF} = 0\text{ A}$	-20		20	mV
		$ I_{VTT}  \leq 1\text{ A}$ , $1.2 \leq V_{VDDQSNS} \leq 1.8\text{ V}$ , $I_{VTTREF} = 0\text{ A}$	-30		30	
		$ I_{VTT}  \leq 2\text{ A}$ , $1.4\text{ V} \leq V_{VDDQSNS} \leq 1.8\text{ V}$ , $I_{VTTREF} = 0\text{ A}$	-40		40	
		$ I_{VTT}  \leq 1.5\text{ A}$ , $1.2\text{ V} \leq V_{VDDQSNS} \leq 1.4\text{ V}$ , $I_{VTTREF} = 0\text{ A}$	-40		40	
$I_{VTTOCLSRC}$	Source current limit	$V_{VDDQSNS} = 1.8\text{ V}$ , $V_{VTT} = V_{VTTSENS} = 0.7\text{ V}$ , $I_{VTTREF} = 0\text{ A}$	2	3		A
$I_{VTTOCLSNK}$	Sink current limit	$V_{VDDQSNS} = 1.8\text{ V}$ , $V_{VTT} = V_{VTTSENS} = 1.1\text{ V}$ , $I_{VTTREF} = 0\text{ A}$	2	3		
$I_{VTTLK}$	Leakage current	$T_J = 25^{\circ}\text{C}$ , $V_{S3} = 0\text{ V}$ , $V_{S5} = 5\text{ V}$ , $V_{VTT} = V_{VTTREF}$			5	
$I_{VTTSENSBIAS}$	VTTSENS input bias current	$V_{S3} = 5\text{ V}$ , $V_{S5} = 5\text{ V}$ , $V_{VTTSENS} = V_{VTTREF}$	-0.5	0.0	0.5	$\mu\text{A}$
$I_{VTTSENSLK}$	VTTSENS leakage current	$V_{S3} = 0\text{ V}$ , $V_{S5} = 5\text{ V}$ , $V_{VTTSENS} = V_{VTTREF}$	-1	0	1	
$I_{VTTDIS}$	VTT Discharge current	$T_J = 25^{\circ}\text{C}$ , $V_{S3} = V_{S5} = 0\text{ V}$ , $V_{VDDQSNS} = 1.8\text{ V}$ , $V_{VTT} = 0.5\text{ V}$ , $I_{VTTREF} = 0\text{ A}$		7.8		mA
<b>VDDQ OUTPUT</b>						
$V_{VDDQSNS}$	VDDQ sense voltage			$V_{REFIN}$		
$V_{VDDQSNSSTOL}$	VDDQSNS regulation voltage tolerance to REFIN	$T_J = 25^{\circ}\text{C}$	-3		3	mV
$I_{VDDQSNS}$	VDDQSNS input current	$V_{VDDQSNS} = 1.8\text{ V}$		39		$\mu\text{A}$
$I_{REFIN}$	REFIN input current	$V_{REFIN} = 1.8\text{ V}$	-0.1	0.0	0.1	$\mu\text{A}$
$I_{VDDQDIS}$	VDDQ discharge current	$V_{S3} = V_{S5} = 0\text{ V}$ , $V_{VDDQSNS} = 0.5\text{ V}$ , MODE pin pulled down to GND through 47 k $\Omega$ (Non-tracking)		12		mA
$I_{VLDOINDIS}$	VLDOIN discharge current	$V_{S3} = V_{S5} = 0\text{ V}$ , $V_{VDDQSNS} = 0.5\text{ V}$ , MODE pin pulled down to GND through 100 k $\Omega$ (Non-tracking)		1.2		A
<b>SWITCH MODE POWER SUPPLY (SMPS) FREQUENCY</b>						
$f_{SW}$	VDDQ switching frequency	$V_{IN} = 5\text{ V}$ , $V_{VDDQSNS} = 1.8\text{ V}$ , $R_{\text{MODE}} = 100\text{ k}\Omega$		300		kHz
		$V_{IN} = 5\text{ V}$ , $V_{VDDQSNS} = 1.8\text{ V}$ , $R_{\text{MODE}} = 200\text{ k}\Omega$		400		

## 7.5 Electrical Characteristics (continued)

$T_J = -55^\circ\text{C}$  to  $125^\circ\text{C}$ ,  $V_{V5IN} = 5\text{ V}$ , VLDOIN is connected to VDDQ output,  $V_{MODE} = 0\text{ V}$ ,  $V_{S3} = V_{S5} = 5\text{ V}$  (unless otherwise noted)

PARAMETER		TEST CONDITION	MIN	TYP	MAX	UNIT
$t_{ON(min)}$	Minimum on time	DRVH rising to falling <sup>1</sup>		60		ns
$t_{OFF(min)}$	Minimum off time	DRVH falling to rising	200	320	450	



## 7.5 Electrical Characteristics (continued)

$T_J = -55^{\circ}\text{C}$  to  $125^{\circ}\text{C}$ ,  $V_{V5IN} = 5\text{ V}$ , VLDOIN is connected to VDDQ output,  $V_{\text{MODE}} = 0\text{ V}$ ,  $V_{S3} = V_{S5} = 5\text{ V}$  (unless otherwise noted)

PARAMETER		TEST CONDITION	MIN	TYP	MAX	UNIT
<b>VDDQ MOSFET DRIVER</b>						
$R_{\text{DRVH}}$	DRVH resistance	Source, $I_{\text{DRVH}} = -50\text{ mA}$		1.6	3.0	$\Omega$
		Sink, $I_{\text{DRVH}} = 50\text{ mA}$		0.6	1.5	
$R_{\text{DRVL}}$	DRVL resistance	Source, $I_{\text{DRVL}} = -50\text{ mA}$		0.9	2.0	$\Omega$
		Sink, $I_{\text{DRVL}} = 50\text{ mA}$		0.5	1.2	
$t_{\text{DEAD}}$	Dead time	DRVH-off to DRVL-on		10		ns
		DRVL-off to DRVH-on		20		
<b>INTERNAL BOOT STRAP SW</b>						
$V_{\text{FBST}}$	Forward voltage	$V_{V5IN-VBST}$ , $T_J = 25^{\circ}\text{C}$ , $I_F = 10\text{ mA}$		0.1	0.2	V
$I_{\text{VBSTLK}}$	VBST leakage current	$T_J = 25^{\circ}\text{C}$ , $V_{\text{VBST}} = 33\text{ V}$ , $V_{\text{SW}} = 28\text{ V}$		0.01	1.5	$\mu\text{ A}$
<b>LOGIC THRESHOLD</b>						
$I_{\text{MODE}}$	MODE source current		14	15	16	$\mu\text{ A}$
$V_{\text{THMODE}}$	MODE threshold voltage	MODE 0	580	600	620	mV
		MODE 1	829	854	879	
		MODE 2	1202	1232	1262	
		MODE 3	1760	1800	1840	
$V_{\text{IL}}$	S3/S5 low-level voltage				0.5	V
$V_{\text{IH}}$	S3/S5 high-level voltage		1.8			
$V_{\text{IHYST}}$	S3/S5 hysteresis voltage			0.25		
$V_{\text{ILK}}$	S3/S5 input leak current		-1	0	1	$\mu\text{ A}$
<b>SOFT START</b>						
$t_{\text{SS}}$	VDDQ soft-start time	Internal soft-start time, $C_{\text{VREF}} = 0.1\ \mu\text{ F}$ , S5 rising to $V_{\text{VDDQSNS}} > 0.99 \times V_{\text{REFIN}}$		1.1		ms
<b>PGOOD COMPARATOR</b>						
$V_{\text{THPG}}$	VDDQ PGOOD threshold	PGOOD in from higher	106%	108%	110%	
		PGOOD in from lower	90%	92%	94%	
		PGOOD out to higher	114%	116%	118%	
		PGOOD out to lower	82%	84%	86%	
$I_{\text{PG}}$	PGOOD sink current	$V_{\text{PGOOD}} = 0.5\text{ V}$	3	5.9		mA
$t_{\text{PGDLY}}$	PGOOD delay time	Delay for PGOOD in	0.8	1	1.2	ms
		Delay for PGOOD out, with 100 mV over drive		330		ns
$t_{\text{PGSSDLY}}$	PGOOD start-up delay	$C_{\text{VREF}} = 0.1\ \mu\text{ F}$ , S5 rising to PGOOD rising		2.5		ms
<b>PROTECTIONS</b>						
$I_{\text{TRIP}}$	TRIP source current	$T_J = 25^{\circ}\text{C}$ , $V_{\text{TRIP}} = 0.4\text{ V}$	9	10	11	$\mu\text{ A}$
$TC_{\text{TRIP}}$	TRIP source current temperature coefficient <sup>1</sup>			4700		ppm/ $^{\circ}\text{C}$
$V_{\text{TRIP}}$	$V_{\text{TRIP}}$ voltage range		0.2		3	V
$V_{\text{OCL}}$	Current limit threshold	$V_{\text{TRIP}} = 3.0\text{ V}$	360	375	390	mV
		$V_{\text{TRIP}} = 1.6\text{ V}$	190	200	210	
		$V_{\text{TRIP}} = 0.2\text{ V}$	20	25	30	
$V_{\text{OCLN}}$	Negative current limit threshold	$V_{\text{TRIP}} = 3.0\text{ V}$	-390	-375	-360	mV
		$V_{\text{TRIP}} = 1.6\text{ V}$	-210	-200	-190	
		$V_{\text{TRIP}} = 0.2\text{ V}$	-30	-25	-20	
$V_{\text{ZC}}$	Zero cross detection offset			0		mV
$V_{\text{UVLO}}$	V5IN UVLO threshold voltage	Wake-up	4.2	4.4	4.5	V
		Shutdown	3.7	3.9	4.1	
$V_{\text{OVP}}$	VDDQ OVP threshold voltage	OVP detect voltage	118%	120%	122%	
$t_{\text{OVPDLY}}$	VDDQ OVP propagation delay	With 100 mV over drive		430		ns

### 7.5 Electrical Characteristics (continued)

T<sub>J</sub> = - 55°C to 125°C, VV5IN = 5 V, VLDOIN is connected to VDDQ output, V<sub>MODE</sub> = 0 V, V<sub>S3</sub> = V<sub>S5</sub> = 5 V (unless otherwise noted)

PARAMETER		TEST CONDITION	MIN	TYP	MAX	UNIT
V <sub>UVP</sub>	VDDQ UVP threshold voltage	UVP detect voltage	66%	68%	70%	
t <sub>UVPDLY</sub>	VDDQ UVP delay			1		ms
t <sub>UVPENDLY</sub>	VDDQ UVP enable delay			1.2		ms
V <sub>OOB</sub>	OOB threshold voltage			108%		
<b>THERMAL SHUTDOWN</b>						
T <sub>SDN</sub>	Thermal shutdown threshold	Shutdown temperature <sup>1</sup>		140		°C
		Hysteresis <sup>1</sup>		10		

1. Ensured by design. Not production tested.

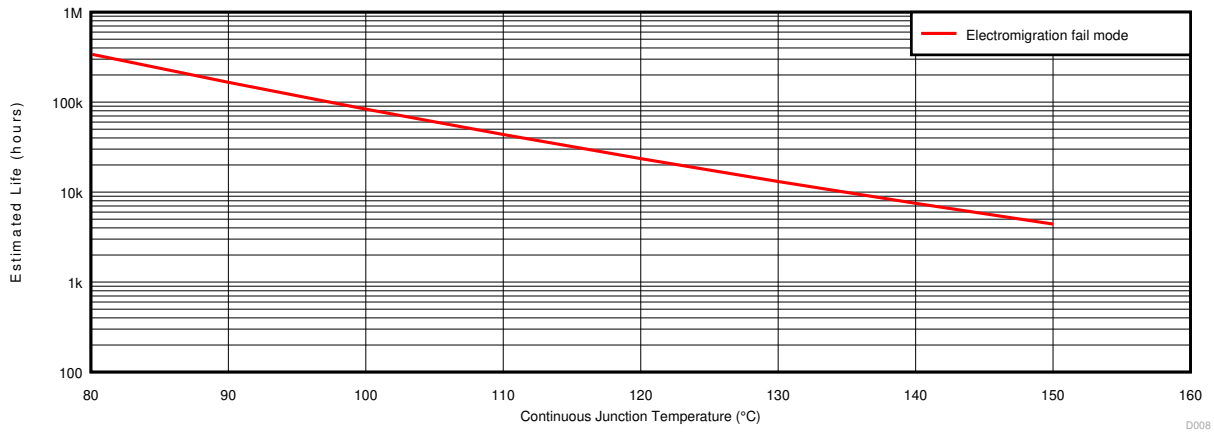

- A. See data sheet for absolute maximum and minimum recommended operating conditions.
- B. Silicon operating life design goal is 10 years at 105°C junction temperature (does not include package interconnect life).
- C. Enhanced plastic product disclaimer applies.

图 7-1. TPS51216-EP Derating Chart

## 7.6 Typical Characteristics



图 7-2. V5IN Supply Current vs Junction Temperature



图 7-3. V5IN Shutdown Current vs Junction Temperature

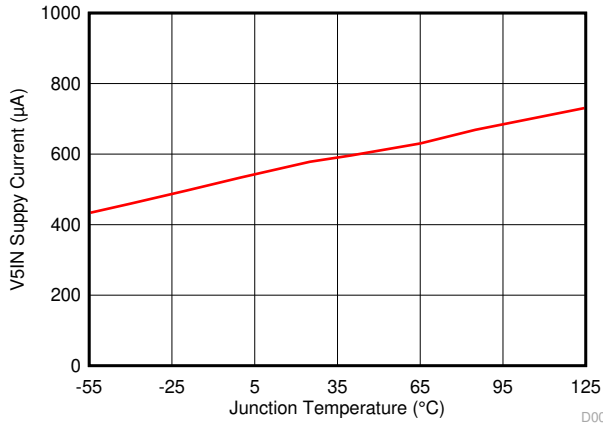

图 7-4. VLDOIN Supply Current vs Junction Temperature

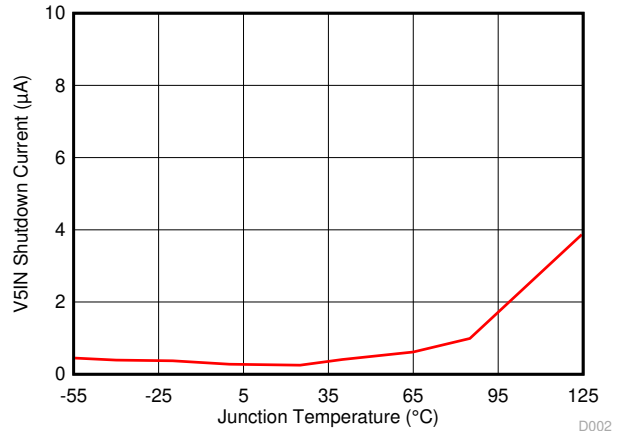

图 7-5. Current Sense Current vs Junction Temperature

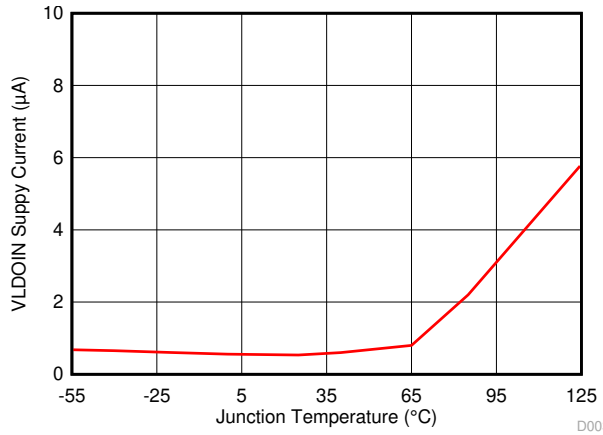

图 7-6. OVP/UVP Threshold vs Junction Temperature

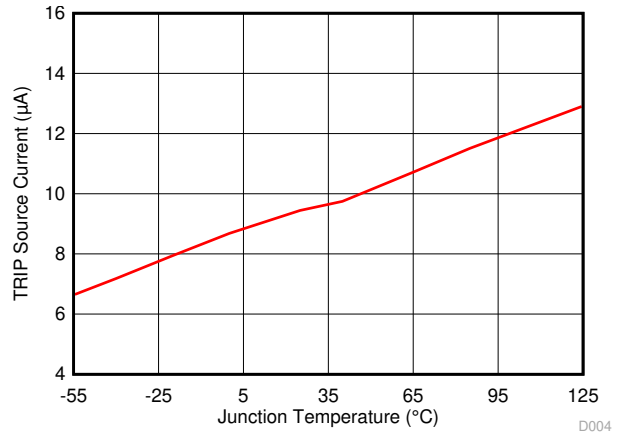

图 7-7. VDDQSNS Discharge Current vs Junction Temperature

## 7.6 Typical Characteristics (continued)

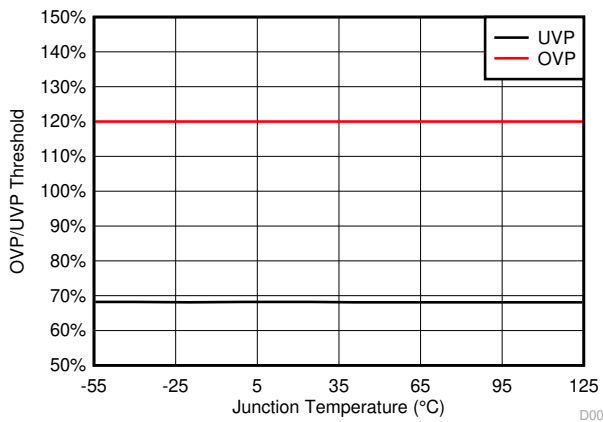

图 7-8. VTT Discharge Current vs Junction Temperature

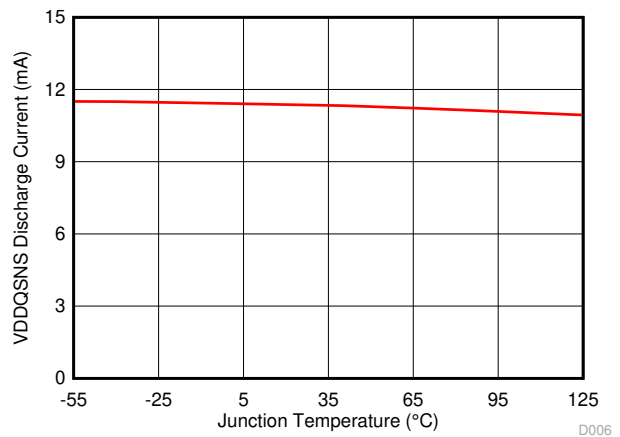

图 7-9. Switching Frequency vs Input Voltage

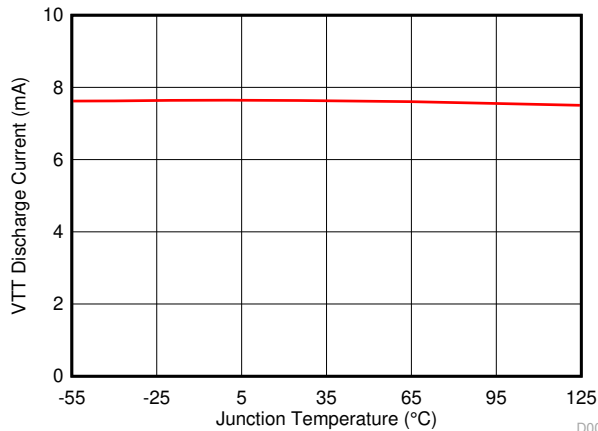

图 7-10. Switching Frequency vs Input Voltage

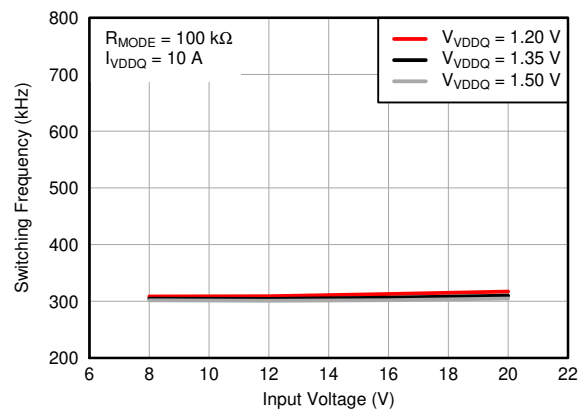

图 7-11. Switching Frequency vs Load Current

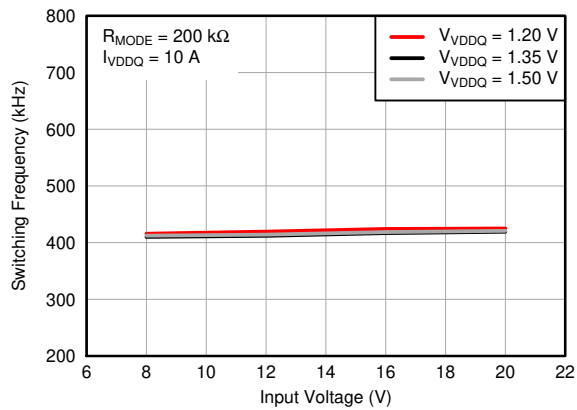

图 7-12. Switching Frequency vs Load Current

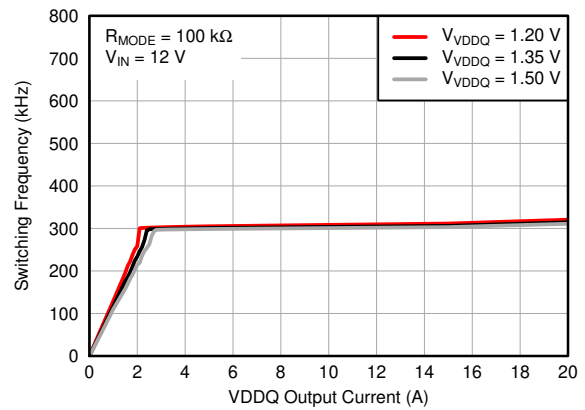

图 7-13. Load Regulation

### 7.6 Typical Characteristics (continued)

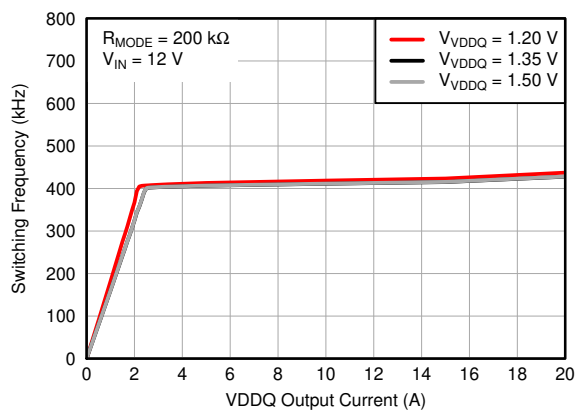

图 7-14. Line Regulation

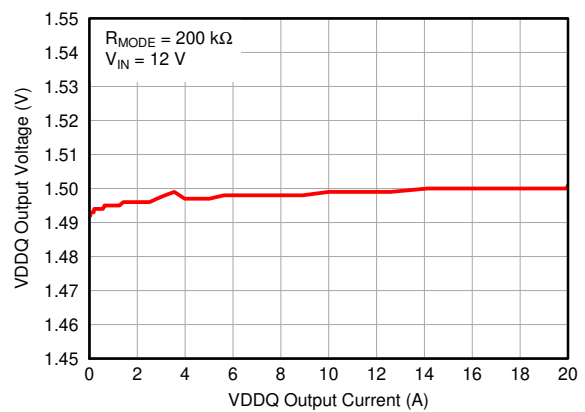

图 7-15. VTTREF Load Regulation

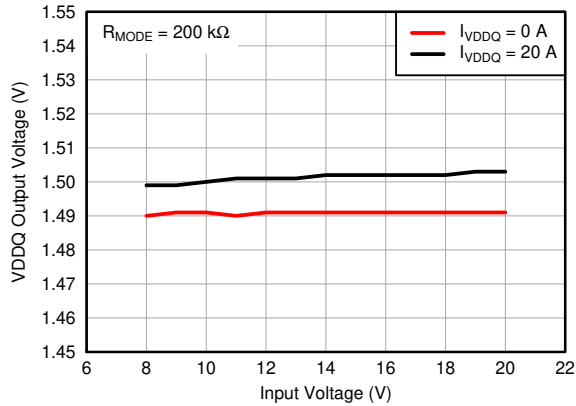

图 7-16. VTTREF Load Regulation

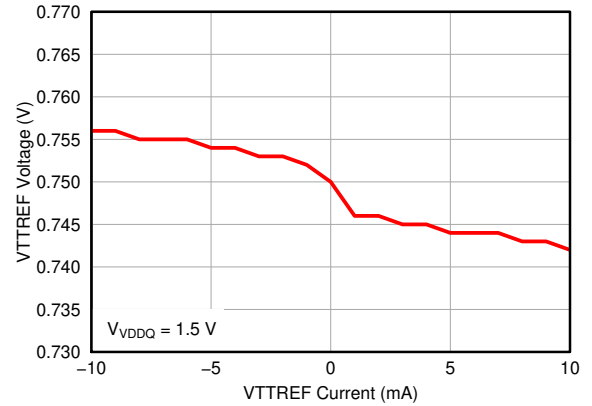

图 7-17. VTTREF Load Regulation

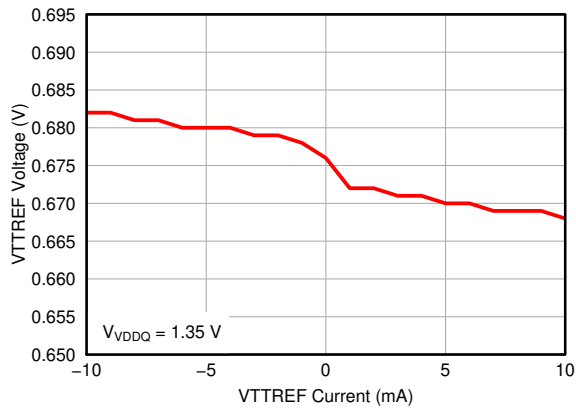

图 7-18. VTT Load Regulation

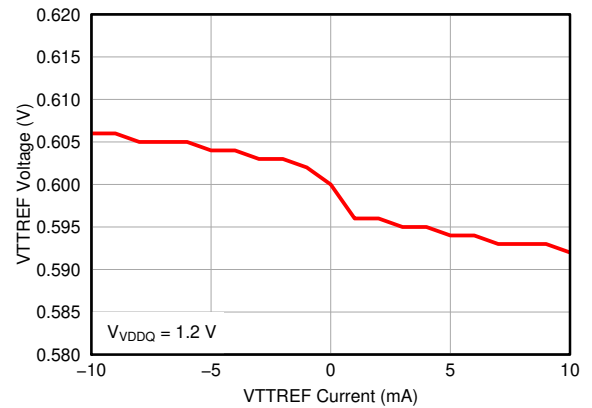

图 7-19. VTT Load Regulation

## 7.6 Typical Characteristics (continued)

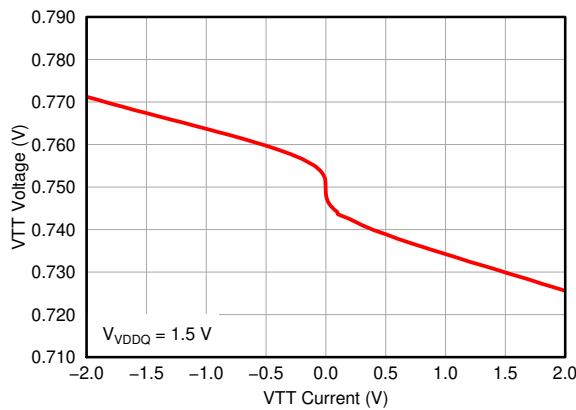

图 7-20. VTT Load Regulation

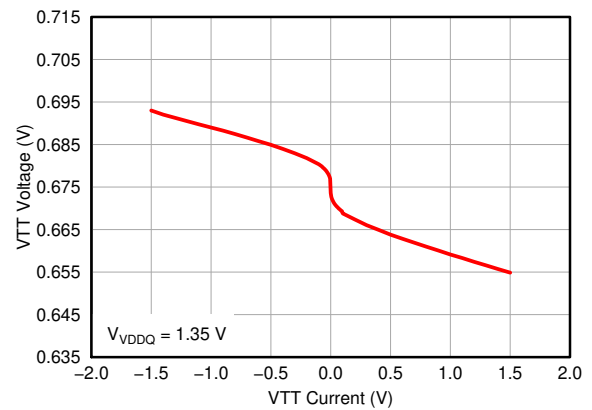

图 7-21. Efficiency

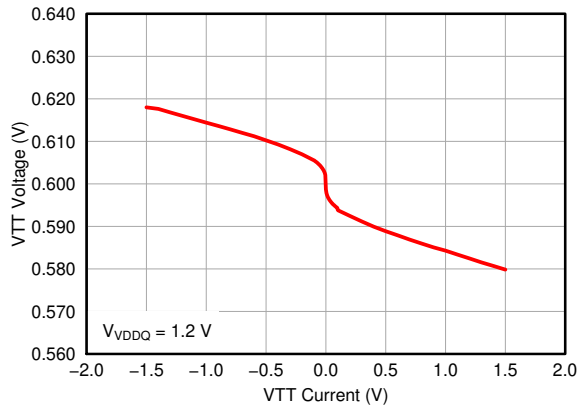

图 7-22. 1.5-V Load Transient Response

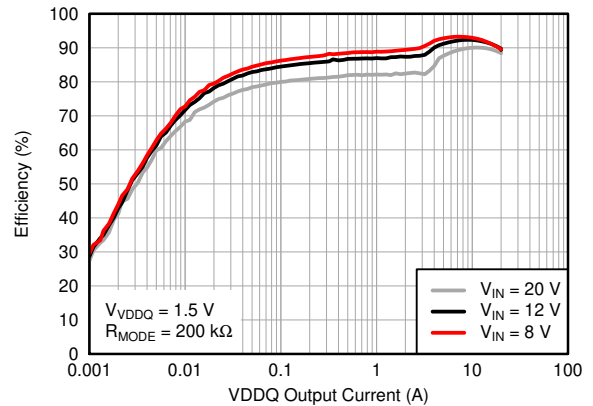

图 7-23. VTT Load Transient Response

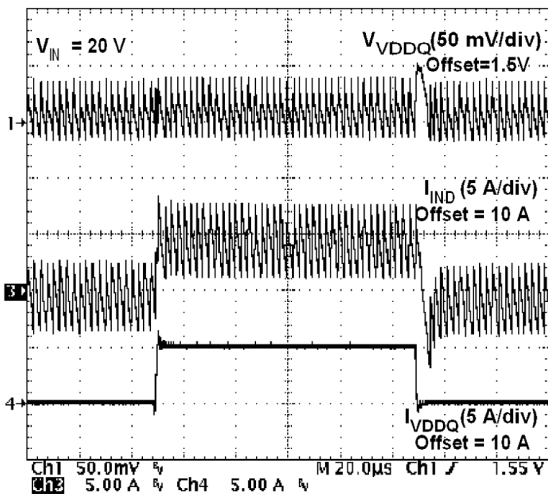

图 7-24. 1.5-V Startup Waveforms

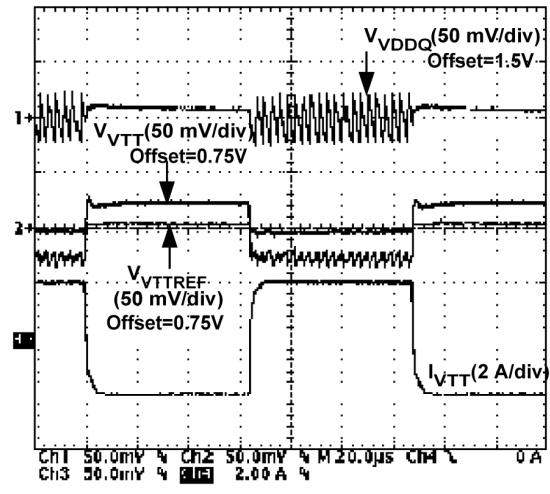

图 7-25. 1.5-V Startup Waveforms (0.5-V Pre-Biased)

### 7.6 Typical Characteristics (continued)

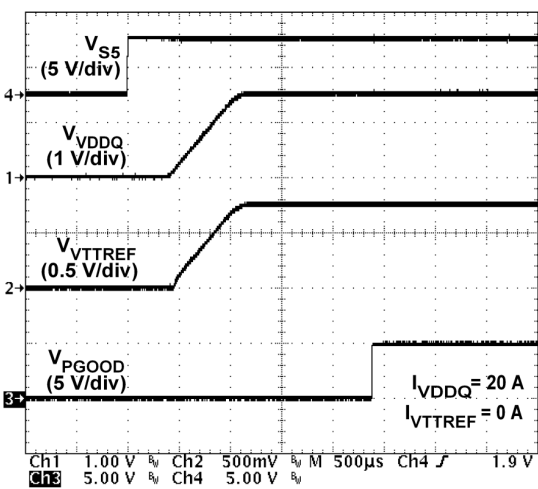

图 7-26. 1.5-V Soft-Stop Waveforms (Tracking Discharge)

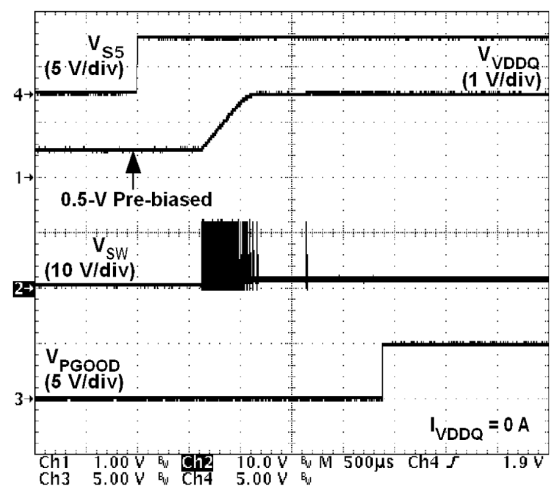

图 7-27. 1.5-V Soft-Stop Waveforms (Non-Tracking Discharge)

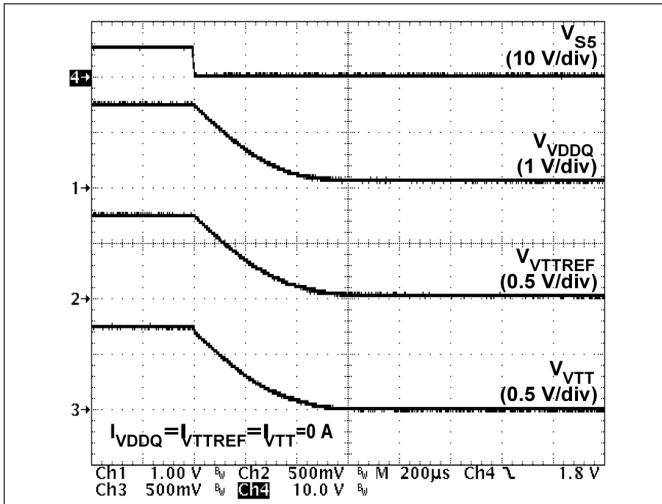

图 7-28. VTT Bode Plot (Sink)

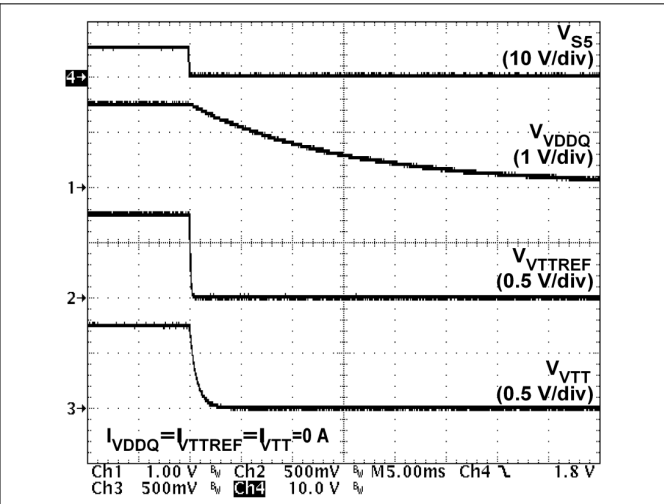

图 7-29. VTT Bode Plot (Source)



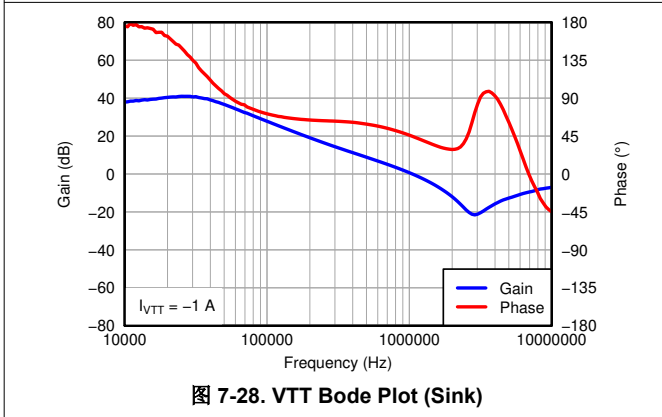

### 8.3.2 VREF and REFIN, VDDQ Output Voltage

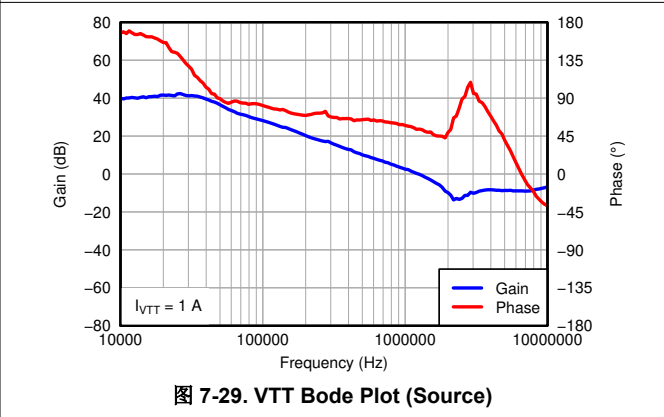
The part provides a 1.8-V,  $\pm 0.8\%$  accurate, voltage reference from VREF. This output has a 300- $\mu$ A (max) current capability to drive the REFIN input voltage through a voltage divider circuit. A capacitor with a value of 0.1- $\mu$ F or larger should be attached close to the VREF terminal.

The VDDQ switch-mode power supply (SMPS) output voltage is defined by REFIN voltage, within the range between 0.7 V and 1.8 V, programmed by the resistor-divider connected between VREF and GND. (See [Figure 9.2.2.2](#).) A few nano farads of capacitance from REFIN to GND is recommended for stable operation.

### 8.3.3 Soft-Start and Powergood

TPS51216-EP provides integrated VDDQ soft-start functions to suppress in-rush current at start-up. The soft-start is achieved by controlling internal reference voltage ramping up. [Figure 8-1](#) shows the start-up waveforms. The switching regulator waits for 400  $\mu$ s after S5 assertion. The MODE pin voltage is read in this period. A typical VDDQ ramp up duration is 700  $\mu$ s.

TPS51216-EP has a powergood open-drain output that indicates the VDDQ voltage is within the target range. The target voltage window and transition delay times of the PGOOD comparator are  $\pm 8\%$  (typ) and 1-ms delay for assertion (low to high), and  $\pm 16\%$  (typ) and 330-ns delay for de-assertion (high to low) during running. The PGOOD comparator is enabled 1.1 ms after VREF is raised high and the start-up delay is 2.5 ms. Note that the time constant which is composed of the REFIN capacitor and a resistor divider needs to be short enough to reach the target value before PGOOD comparator enabled.



图 8-1. Typical Start-up Waveforms

### 8.3.4 Power State Control

The TPS51216-EP has two input pins, S3 and S5, to provide simple control scheme of power state. All of VDDQ, VTTREF and VTT are turned on at S0 state (S3 = S5 = high). In S3 state (S3 = low, S5 = high), VDDQ and VTTREF voltages are kept on while VTT is turned off and left at high impedance state (high-Z). The VTT output floats and does not sink or source current in this state. In S4/S5 states (S3=S5=low), all of the three outputs are turned off and discharged to GND according to the discharge mode selected by MODE pin. Each state code represents as follow; S0 = full ON, S3 = suspend to RAM (STR), S4 = suspend to disk (STD), S5 = soft OFF. (See [Table 8-1](#))

表 8-1. S3/S5 Power State Control

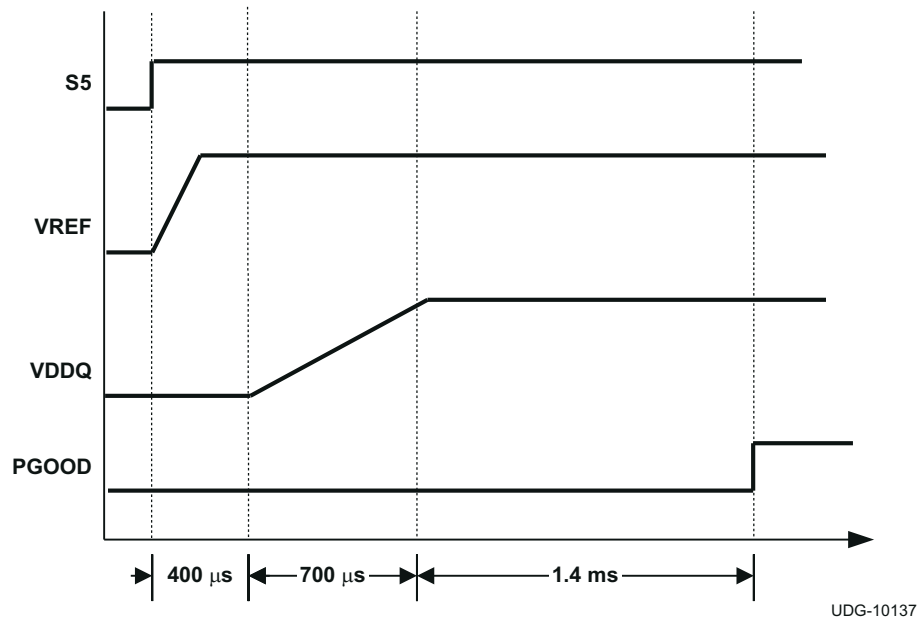
STATE	S3	S5	VREF	VDDQ	VTTREF	VTT
S0	HI	HI	ON	ON	ON	ON
S3	LO	HI	ON	ON	ON	OFF (high-Z)
S4/S5	LO	LO	OFF	OFF (discharge)	OFF (discharge)	OFF (discharge)

### 8.3.5 Discharge Control

In S4/S5 state, VDDQ, VTT, and VTTREF outputs are discharged based on the respective discharge mode selected above. The tracking discharge mode discharges VDDQ output through the internal VTT regulator transistors enabling quick discharge operation. The VTT output maintains tracking of the VTTREF voltage in this mode. (Refer to [图 7-26](#).) After 4 ms of tracking discharge operation, the mode changes to non-tracking discharge. The VDDQ output must be connected to the VLDOIN pin in this mode. The non-tracking mode discharges the VDDQ and VTT pins using internal MOSFETs that are connected to corresponding output terminals. The non-tracking discharge is slow compared with the tracking discharge due to the lower current capability of these MOSFETs. (Refer to [图 7-27](#).)

### 8.3.6 VTT Overcurrent Protection

The LDO has an internally fixed constant overcurrent limiting of 3-A (typ) for both sink and source operation.

### 8.3.7 V5IN Undervoltage Lockout (UVLO) Protection

TPS51216-EP has a 5-V supply UVLO protection threshold. When the V5IN voltage is lower than UVLO threshold voltage, typically 3.93 V, VDDQ, VTT, and VTTREF are shut off. This is a non-latch protection.

### 8.3.8 Thermal Shutdown

TPS51216-EP includes an internal temperature monitor. If the temperature exceeds the threshold value, 140°C (typical), VDDQ, VTT and VTTREF are shut off. The thermal shutdown state of VDDQ is open, VTT and VTTREF are high impedance (high-Z) respectively, and the discharge functions are disabled. This is a non-latch protection and the operation is restarted with soft-start sequence when the device temperature is reduced by 10°C (typical).

## 8.4 Device Functional Modes

### 8.4.1 MODE Pin Configuration

The TPS51216-EP reads the MODE pin voltage when the S5 signal is raised high and stores the status in a register. A 15- $\mu$ A current is sourced from the MODE pin during this time to read the voltage across the resistor connected between the pin and GND. 表 8-2 shows resistor values, corresponding switching frequency, and discharge mode configurations.

表 8-2. MODE Selection

MODE NO.	RESISTANCE BETWEEN MODE AND GND (k $\Omega$ )	SWITCHING FREQUENCY (kHz)	DISCHARGE MODE
3	200	400	Tracking
2	100	300	
1	68	300	Non-tracking
0	47	400	

## 9 Application and Implementation

### 备注

以下应用部分中的信息不属于 TI 器件规格的范围，TI 不承担其准确性和完整性。TI 的客户应负责确定器件是否适用于其应用。客户应验证并测试其设计，以确保系统功能。

### 9.1 Application Information

TPS51216-EP is highly integrated synchronous step-down buck solution. The device is used to convert a higher DC-DC voltage to lower DC output voltage to provide VDDQ and VTT for various DDR memory power solutions.

#### 9.1.1 D-CAP Mode

图 9-1 shows a simplified model of D-CAP mode architecture.



图 9-1. Simplified D-CAP Model

The VDDQSNS voltage is compared with REFIN voltage. The PWM comparator creates a set signal to turn on the high-side MOSFET. The gain and speed of the comparator is high enough to maintain the voltage at the beginning of each on-cycle (or the end of each off-cycle) to be substantially constant. The DC output voltage monitored at VDDQ may have line regulation due to ripple amplitude that slightly increases as the input voltage increase. The D-CAP mode offers flexibility on output inductance and capacitance selections and provides ease-of-use with a low external component count. However, it requires a sufficient amount of output ripple voltage for stable operation and good jitter performance.

The requirement for loop stability is simple and is described in 方程式 1. The 0-dB frequency,  $f_0$  defined in 方程式 1, is recommended to be lower than 1/3 of the switching frequency to secure proper phase margin.

$$f_0 = \frac{1}{2\pi \times \text{ESR} \times C_{\text{OUT}}} \leq \frac{f_{\text{SW}}}{3} \quad (1)$$

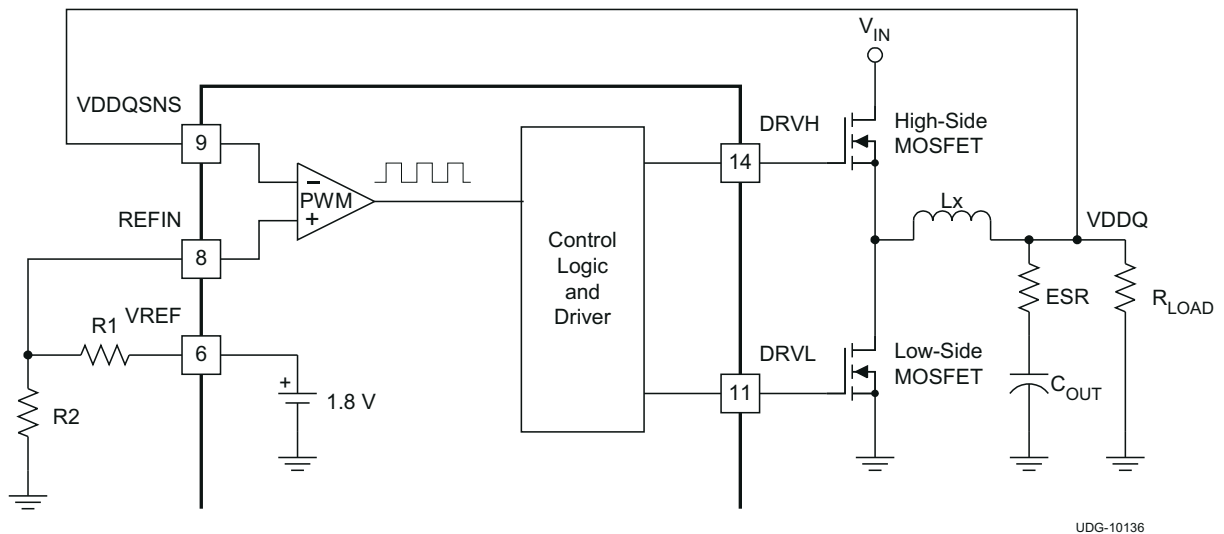
where

- ESR is the effective series resistance of the output capacitor
- $C_{\text{OUT}}$  is the capacitance of the output capacitor
- $f_{\text{SW}}$  is switching frequency

Jitter is another attribute caused by signal-to-noise ratio of the feedback signal. One of the major factors that determine jitter performance in D-CAP mode is the down-slope angle of the VDDQSNS ripple voltage. 图 9-2 shows, in the same noise condition, a jitter is improved by making the slope angle larger.



图 9-2. Ripple Voltage Slope and Jitter Performance

For a good jitter performance, use the recommended down slope of approximately 20 mV per switching period as shown in 图 9-2 and 方程式 2.

$$\frac{V_{OUT} \times ESR}{f_{SW} \times L_X} \geq 20 \text{ mV} \quad (2)$$

where

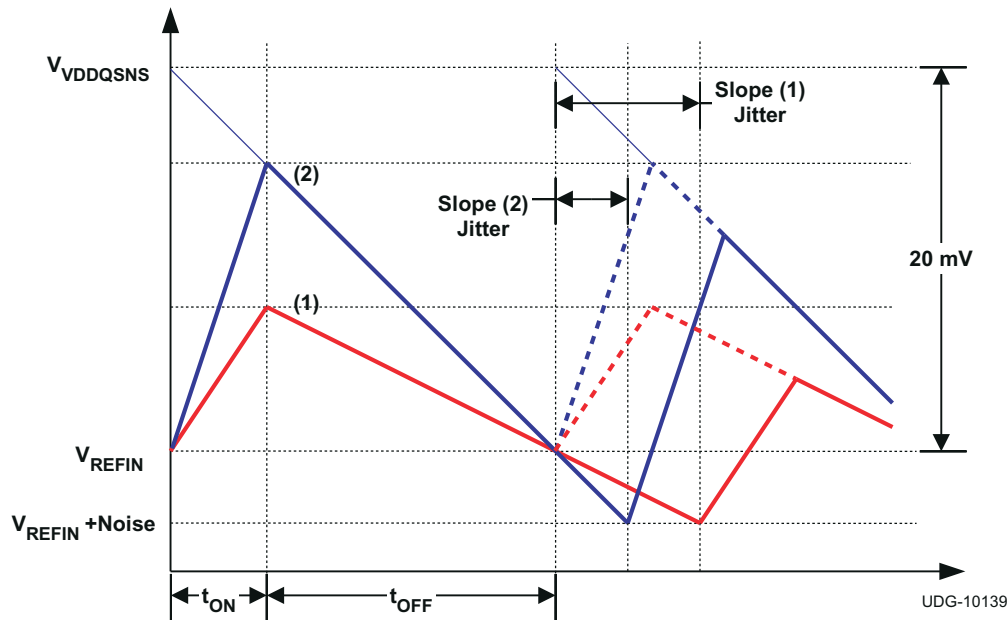
- $V_{OUT}$  is the VDDQ output voltage
- $L_X$  is the inductance

### 9.1.2 Light-Load Operation

In auto-skip mode, the TPS51216-EP SMPS control logic automatically reduces its switching frequency to improve light-load efficiency. To achieve this intelligence, a zero cross detection comparator is used to prevent negative inductor current by turning off the low-side MOSFET. 方程式 3 shows the boundary load condition of this skip mode and continuous conduction operation.

$$I_{LOAD(LL)} = \frac{(V_{IN} - V_{OUT})}{2 \times L_X} \times \frac{V_{OUT}}{V_{IN}} \times \frac{1}{f_{SW}} \quad (3)$$

### 9.1.3 VTT and VTTREF

TPS51216-EP integrates two high performance, low-dropout linear regulators, VTT and VTTREF, to provide complete DDR2/DDR3/DDR3L power solutions. The VTTREF has a 10-mA sink/source current capability, and tracks  $\frac{1}{2}$  of VDDQSNS with  $\pm 1\%$  accuracy using an on-chip  $\frac{1}{2}$  divider. A 0.22- $\mu$ F (or larger) ceramic capacitor must be connected close to the VTTREF terminal for stable operation. The VTT responds quickly to track VTTREF within  $\pm 40$  mV at all conditions, and the current capability is 2 A for both sink and source. A 10- $\mu$ F (or larger) ceramic capacitor must be connected close to the VTT terminal for stable operation. To achieve tight regulation with minimum effect of wiring resistance, a remote sensing terminal, VTTSENS, should be connected to

the positive node of the VTT output capacitors as a separate trace from the high-current line to the VTT pin. (Refer to [# 11.1](#) for details.)

When VTT is not required in the design, the following treatments are strongly recommended.

- Connect VLDOIN to VDDQ.
- Tie VTTSENS to VTT, and remove capacitors from VTT to float.
- Connect VTTGND to GND.
- Select MODE 0 or MODE 1 shown in [表 8-2](#) (select non-tracking discharge mode).
- Maintain a 0.22- $\mu$ F capacitor connected at VTTREF.
- Pull down S3 to GND with 1-k $\Omega$  resistance.



图 9-3. Application Circuit When VTT is not Required

#### 9.1.4 VDDQ Overvoltage and Undervoltage Protection

TPS51216-EP sets the overvoltage protection (OVP) when the VDDQSNS voltage reaches a level 20% (typ) higher than the REFIN voltage. When an OV event is detected, the controller latches DRVH low and DRVL high. VTTREF and VTT are turned off and discharged using the non-tracking discharge MOSFETs regardless of the tracking mode.

The undervoltage protection (UVP) latch is set when the VDDQSNS voltage remains lower than 68% (typ) of the REFIN voltage for 1 ms or longer. In this fault condition, the controller latches DRVH low and DRVL low and discharges the VDDQ, VTT, and VTTREF outputs. UVP detection function is enabled after 1.2 ms of SMPS operation to ensure startup.

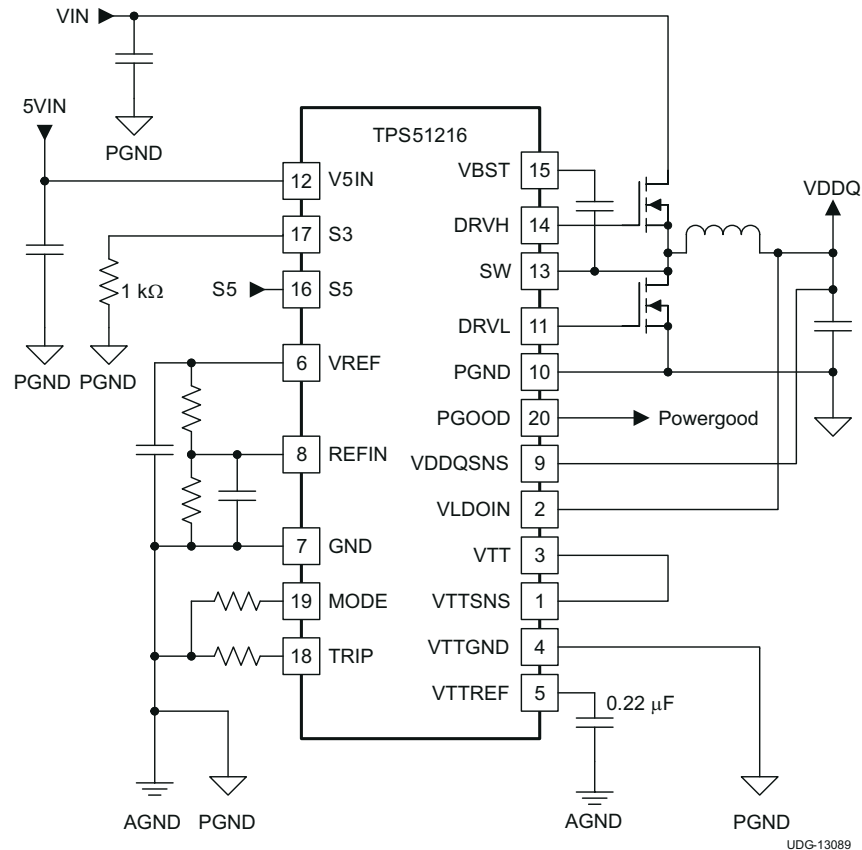
To release the OVP and UVP latches, toggle S5 or adjust the V5IN voltage down and up beyond the undervoltage lockout threshold.



## 9.2.1 Design Requirements

See 表 9-1 for the design parameters.

表 9-1. Design Parameters

V <sub>IN</sub>	V <sub>DDQ</sub>	I <sub>VDDQ</sub>	V <sub>TT</sub>	I <sub>VTT</sub>	F <sub>SW</sub>
8 to 20 V	1.5 V	20 A	0.75 V	2 A	400 kHz

## 9.2.2 Detailed Design Procedure

### 9.2.2.1 List of Materials

表 9-2. DDR3, 400-kHz Application Circuit, List of Materials

REFERENCE DESIGNATOR	QTY	SPECIFICATION	MANUFACTURER	PART NUMBER
C8, C9, C10	3	10 μF, 25 V	Taiyo Yuden	TMK325BJ106MM
C11	1	330 μF, 2V, 6 mΩ	Panasonic	EEFSX0D331XE
L1	1	0.56 μH, 21 A, 1.56 mΩ	Panasonic	ETQP4LR56WFC
Q1	1	30 V, 35 A, 8.5 mΩ	Fairchild	FDMS8680
Q2, Q3	2	30 V, 42 A, 3.5 mΩ	Fairchild	FDMS8670AS

For this example, the bulk output capacitor ESR requirement for D-CAP mode is described in 方程式 6, whichever is greater.

$$ESR \geq \frac{20\text{mV} \times f_{\text{SW}} \times L}{V_{\text{OUT}}} \quad \text{or} \quad ESR \geq \frac{3}{2\pi \times f_{\text{SW}} \times C_{\text{OUT}}} \quad (6)$$

### 9.2.2.2 External Components Selection

The external components selection is simple in D-CAP mode.

#### 1. Determine the value of R4 and R5.

The output voltage is determined by the value of the voltage-divider resistor, R4 and R5, as shown in 图 9-4. R4 is connected between VREF and REFIN pins, and R5 is connected between the REFIN pin and GND. Setting R4 as 10-kΩ is a good starting point. Determine R5 using 方程式 7.

$$R5 = \frac{R4}{\left( \frac{1.8}{V_{\text{OUT}} - \left( \frac{I_{\text{IND(ripple)}} \times \text{ESR}}{2} \right)} \right) - 1} \quad (7)$$

#### 2. Choose the inductor.

The inductance value should be determined to yield a ripple current of approximately ¼ to ½ of maximum output current. Larger ripple current increases output ripple voltage and improves the signal-to-noise ratio and helps stable operation.

$$L_X = \frac{1}{I_{\text{IND(ripple)}} \times f_{\text{SW}}} \times \frac{(V_{\text{IN(max)}} - V_{\text{OUT}}) \times V_{\text{OUT}}}{V_{\text{IN(max)}}} = \frac{3}{I_{\text{O(max)}} \times f_{\text{SW}}} \times \frac{(V_{\text{IN(max)}} - V_{\text{OUT}}) \times V_{\text{OUT}}}{V_{\text{IN(max)}}} \quad (8)$$



The inductor needs a low direct current resistance (DCR) to achieve good efficiency, as well as enough room above peak inductor current before saturation. The peak inductor current can be estimated in [方程式 9](#).

$$I_{IND(peak)} = \frac{V_{TRIP}}{8 \times R_{DS(on)}} + \frac{1}{L_X \times f_{SW}} \times \frac{(V_{IN(max)} - V_{OUT}) \times V_{OUT}}{V_{IN(max)}} \quad (9)$$

### 3. Choose the OCL setting resistance, $R_{TRIP}$ .

Combining [方程式 4](#) and [方程式 5](#),  $R_{TRIP}$  can be obtained using [方程式 10](#).

$$R_{TRIP} = \frac{8 \times \left( I_{OCL} - \left( \frac{V_{IN} - V_{OUT}}{2 \times L_X} \right) \times \frac{V_{OUT}}{f_{SW} \times V_{IN}} \right) \times R_{DS(on)}}{I_{TRIP}} \quad (10)$$

### 4. Choose the output capacitors.

TI recommends organic semiconductor capacitors or specialty polymer capacitors. Determine ESR to meet small signal stability and recommended ripple voltage. A quick reference is shown in [方程式 11](#) and [方程式 12](#).

$$\frac{1}{2\pi \times ESR \times C_{OUT}} \leq \frac{f_{SW}}{3} \quad (11)$$

$$\frac{V_{OUT} \times ESR}{f_{SW} \times L_X} \geq 20mV \quad (12)$$

## 9.2.3 Application Curve



图 9-5. Output Ripple

## 10 Power Supply Recommendations

TPS51216-EP is designed to operate from input voltage supply range of 8 to 20 V. This supply must be well regulated. The power supply must be well bypassed for proper electrical performance. See [§ 11.2](#) for recommended bypass capacitor placement.

## 11 Layout

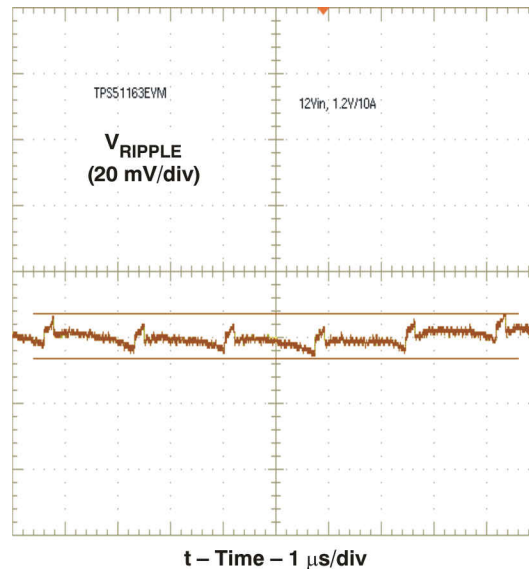
### 11.1 Layout Guidelines

Certain issues must be considered before designing a layout using the TPS51216-EP.

- VIN capacitors, VOUT capacitors, and MOSFETs are the power components and should be placed on one side of the PCB (solder side). Other small signal components should be placed on another side (component side). At least one inner plane should be inserted, connected to ground, in order to shield and isolate the small signal traces from noisy power lines.
- All sensitive analog traces and components such as VDDQSNS, VTTSNS, MODE, REFIN, VREF, and TRIP should be placed away from high-voltage switching nodes such as SW, DRV\_L, DRV\_H, or VBST to avoid coupling. Use internal layers as ground planes and shield feedback trace from power traces and components.
- The DC/DC converter has several high-current loops. The area of these loops should be minimized in order to suppress generating switching noise.
  - The most important loop to minimize the area of is the path from the VIN capacitors through the high and low-side MOSFETs, and back to the capacitors through ground. Connect the negative node of the VIN capacitors and the source of the low-side MOSFET at ground as close as possible. (Refer to loop number 1 of [图 11-1](#))
  - The second important loop is the path from the low-side MOSFET through inductor and VOUT capacitors, and back to source of the low-side MOSFET through ground. Connect source of the low-side MOSFET and negative node of VOUT capacitors at ground as close as possible. (Refer to loop number 2 of [图 11-1](#))
  - The third important loop is of gate driving system for the low-side MOSFET. To turn on the low-side MOSFET, high current flows from V5IN capacitor through gate driver and the low-side MOSFET, and back to negative node of the capacitor through ground. To turn off the low-side MOSFET, high current flows from gate of the low-side MOSFET through the gate driver and PGND, and back to source of the low-side MOSFET through ground. Connect negative node of V5IN capacitor, source of the low-side MOSFET and PGND at ground as close as possible. (Refer to loop number 3 of [图 11-1](#))
- Because the TPS51216-EP controls output voltage referring to voltage across VOUT capacitor, VDDQSNS should be connected to the positive node of VOUT capacitor. In a same manner GND should be connected to the negative node of VOUT capacitor.
- Connect the overcurrent setting resistors from TRIP pin to ground and make the connections as close as possible to the device. The trace from TRIP pin to resistor and from resistor to ground should avoid coupling to a high-voltage switching node.
- Connect the frequency and mode setting resistor from MODE pin to ground, and make the connections as close as possible to the device. The trace from the MODE pin to the resistor and from the resistor to ground should avoid coupling to a high-voltage switching node
- Connections from gate drivers to the respective gate of the high-side or the low-side MOSFET should be as short as possible to reduce stray inductance. Use 0.65 mm (25 mils) or wider trace and vias of at least 0.5 mm (20 mils) diameter along this trace.
- The PCB trace defined as SW node, which connects to the source of the switching MOSFET, the drain of the rectifying MOSFET and the high-voltage side of the inductor, should be as short and wide as possible.
- VLDOIN should be connected to VDDQ output with short and wide traces. An input bypass capacitor should be placed as close as possible to the pin with short and wide connections.
- The output capacitor for VTT should be placed close to the pin with a short and wide connection in order to avoid additional ESR and/or ESL of the trace.
- VTTSNS should be connected to the positive node of the VTT output capacitors as a separate trace from the high-current power line and is strongly recommended to avoid additional ESR and/or ESL. If it is needed to sense the voltage at the point of the load, it is recommended to attach the output capacitors at that point. Also, it is recommended to minimize any additional ESR and/or ESL of ground trace between GND pin and the output capacitors.
- Consider adding a low pass filter (LPF) at VTTSNS in case the ESR of the VTT output capacitors is larger than  $2\text{ m}\Omega$ .

- VDDQSNS can be connected separately from VLDOIN. Remember that this sensing potential is the reference voltage of VTTREF. Avoid any noise generative lines.
- The negative node of the VTT output capacitors and the VTTREF capacitor should be tied together by avoiding common impedance to high-current path of the VTT source/sink current.
- GND pin node represents the reference potential for VTTREF and VTT outputs. Connect GND to negative nodes of VTT capacitors, VTTREF capacitor and VDDQ capacitors with care to avoid additional ESR and/or ESL. GND and PGND should be connected together at a single point.
- In order to effectively remove heat from the package, prepare the thermal land and solder to the package thermal pad. Wide trace of the component-side copper, connected to this thermal land, helps heat spreading. Numerous vias with a 0.3-mm diameter connected from the thermal land to the internal/solder-side ground planes should be used to help dissipation.

**CAUTION**

Do **not** connect PGND pin directly to this thermal land underneath the package.

**11.2 Layout Example**



图 11-1. DC/DC Converter Ground System

## 12 Device and Documentation Support

### 12.1 接收文档更新通知

要接收文档更新通知，请导航至 [ti.com](http://ti.com) 上的器件产品文件夹。点击 [订阅更新](#) 进行注册，即可每周接收产品信息更改摘要。有关更改的详细信息，请查看任何已修订文档中包含的修订历史记录。

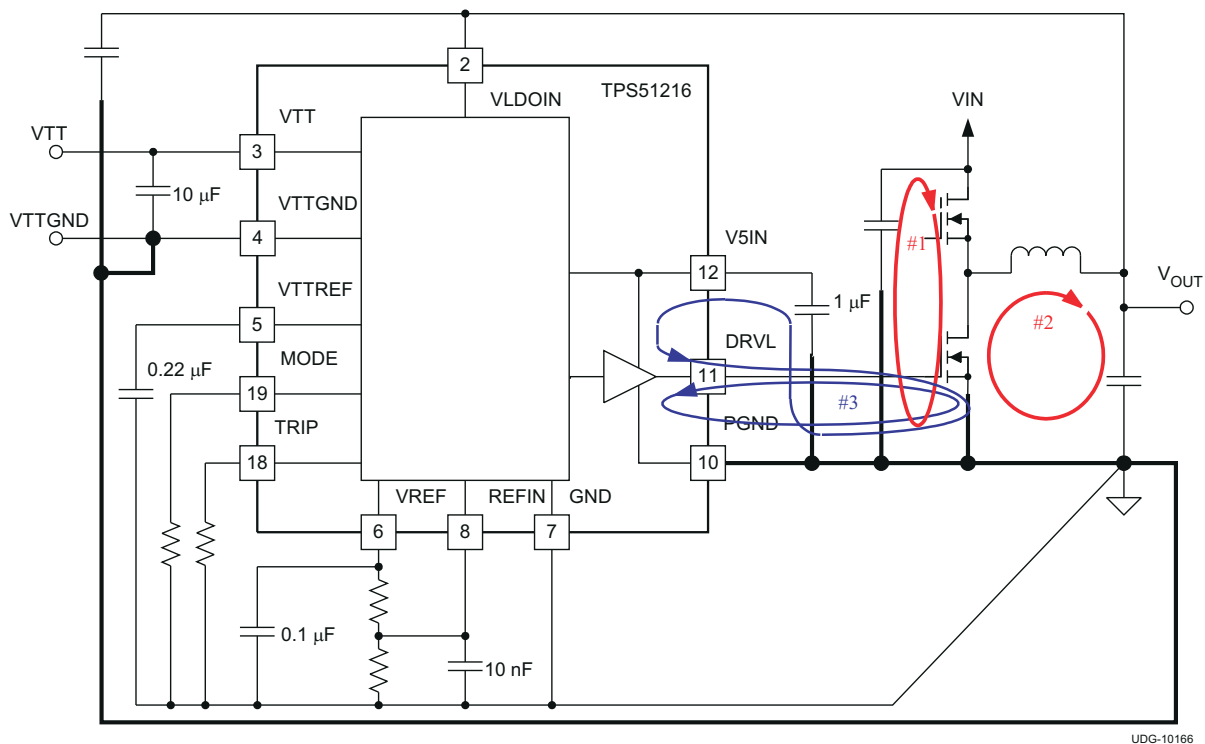
### 12.2 支持资源

[TI E2E™ 支持论坛](#) 是工程师的重要参考资料，可直接从专家获得快速、经过验证的解答和设计帮助。搜索现有解答或提出自己的问题可获得所需的快速设计帮助。

链接的内容由各个贡献者“按原样”提供。这些内容并不构成 TI 技术规范，并且不一定反映 TI 的观点；请参阅 TI 的《[使用条款](#)》。

### 12.3 Trademarks

D-CAP™ is a trademark of Texas Instruments.

TI E2E™ is a trademark of Texas Instruments.

所有商标均为其各自所有者的财产。

### 12.4 Electrostatic Discharge Caution



This integrated circuit can be damaged by ESD. Texas Instruments recommends that all integrated circuits be handled with appropriate precautions. Failure to observe proper handling and installation procedures can cause damage.

ESD damage can range from subtle performance degradation to complete device failure. Precision integrated circuits may be more susceptible to damage because very small parametric changes could cause the device not to meet its published specifications.

### 12.5 术语表

[TI 术语表](#) 本术语表列出并解释了术语、首字母缩略词和定义。

## 13 Mechanical, Packaging, and Orderable Information

The following pages include mechanical, packaging, and orderable information. This information is the most current data available for the designated devices. This data is subject to change without notice and revision of this document. For browser-based versions of this data sheet, refer to the left-hand navigation.

**PACKAGING INFORMATION**

Orderable Device	Status (1)	Package Type	Package Drawing	Pins	Package Qty	Eco Plan (2)	Lead finish/ Ball material (6)	MSL Peak Temp (3)	Op Temp (°C)	Device Marking (4/5)	Samples
TPS51216MRUKREP	ACTIVE	WQFN	RUK	20	3000	RoHS & Green	NIPDAU	Level-3-260C-168 HR	-55 to 125	51216M	<a href="#">Samples</a>
V62/16601-01XE	ACTIVE	WQFN	RUK	20	3000	RoHS & Green	NIPDAU	Level-3-260C-168 HR	-55 to 125	51216M	<a href="#">Samples</a>

(1) The marketing status values are defined as follows:

**ACTIVE:** Product device recommended for new designs.

**LIFEBUY:** TI has announced that the device will be discontinued, and a lifetime-buy period is in effect.

**NRND:** Not recommended for new designs. Device is in production to support existing customers, but TI does not recommend using this part in a new design.

**PREVIEW:** Device has been announced but is not in production. Samples may or may not be available.

**OBSOLETE:** TI has discontinued the production of the device.

(2) **RoHS:** TI defines "RoHS" to mean semiconductor products that are compliant with the current EU RoHS requirements for all 10 RoHS substances, including the requirement that RoHS substance do not exceed 0.1% by weight in homogeneous materials. Where designed to be soldered at high temperatures, "RoHS" products are suitable for use in specified lead-free processes. TI may reference these types of products as "Pb-Free".

**RoHS Exempt:** TI defines "RoHS Exempt" to mean products that contain lead but are compliant with EU RoHS pursuant to a specific EU RoHS exemption.

**Green:** TI defines "Green" to mean the content of Chlorine (Cl) and Bromine (Br) based flame retardants meet JS709B low halogen requirements of <=1000ppm threshold. Antimony trioxide based flame retardants must also meet the <=1000ppm threshold requirement.

(3) MSL, Peak Temp. - The Moisture Sensitivity Level rating according to the JEDEC industry standard classifications, and peak solder temperature.

(4) There may be additional marking, which relates to the logo, the lot trace code information, or the environmental category on the device.

(5) Multiple Device Markings will be inside parentheses. Only one Device Marking contained in parentheses and separated by a "~" will appear on a device. If a line is indented then it is a continuation of the previous line and the two combined represent the entire Device Marking for that device.

(6) Lead finish/Ball material - Orderable Devices may have multiple material finish options. Finish options are separated by a vertical ruled line. Lead finish/Ball material values may wrap to two lines if the finish value exceeds the maximum column width.

**Important Information and Disclaimer:**The information provided on this page represents TI's knowledge and belief as of the date that it is provided. TI bases its knowledge and belief on information provided by third parties, and makes no representation or warranty as to the accuracy of such information. Efforts are underway to better integrate information from third parties. TI has taken and continues to take reasonable steps to provide representative and accurate information but may not have conducted destructive testing or chemical analysis on incoming materials and chemicals. TI and TI suppliers consider certain information to be proprietary, and thus CAS numbers and other limited information may not be available for release.

In no event shall TI's liability arising out of such information exceed the total purchase price of the TI part(s) at issue in this document sold by TI to Customer on an annual basis.

**OTHER QUALIFIED VERSIONS OF TPS51216-EP :**

- Catalog : [TPS51216](#)

## NOTE: Qualified Version Definitions:

- Catalog - TI's standard catalog product

**TAPE AND REEL INFORMATION**

**QUADRANT ASSIGNMENTS FOR PIN 1 ORIENTATION IN TAPE**

\*All dimensions are nominal

Device	Package Type	Package Drawing	Pins	SPQ	Reel Diameter (mm)	Reel Width W1 (mm)	A0 (mm)	B0 (mm)	K0 (mm)	P1 (mm)	W (mm)	Pin1 Quadrant
TPS51216MRUKREP	WQFN	RUK	20	3000	330.0	12.4	3.3	3.3	1.1	8.0	12.0	Q2



**TAPE AND REEL BOX DIMENSIONS**

\*All dimensions are nominal

Device	Package Type	Package Drawing	Pins	SPQ	Length (mm)	Width (mm)	Height (mm)
TPS51216MRUKREP	WQFN	RUK	20	3000	346.0	346.0	33.0

## GENERIC PACKAGE VIEW

**RUK 20**

**WQFN - 0.8 mm max height**

3 x 3, 0.4 mm pitch

PLASTIC QUAD FLATPACK - NO LEAD

This image is a representation of the package family, actual package may vary.  
Refer to the product data sheet for package details.

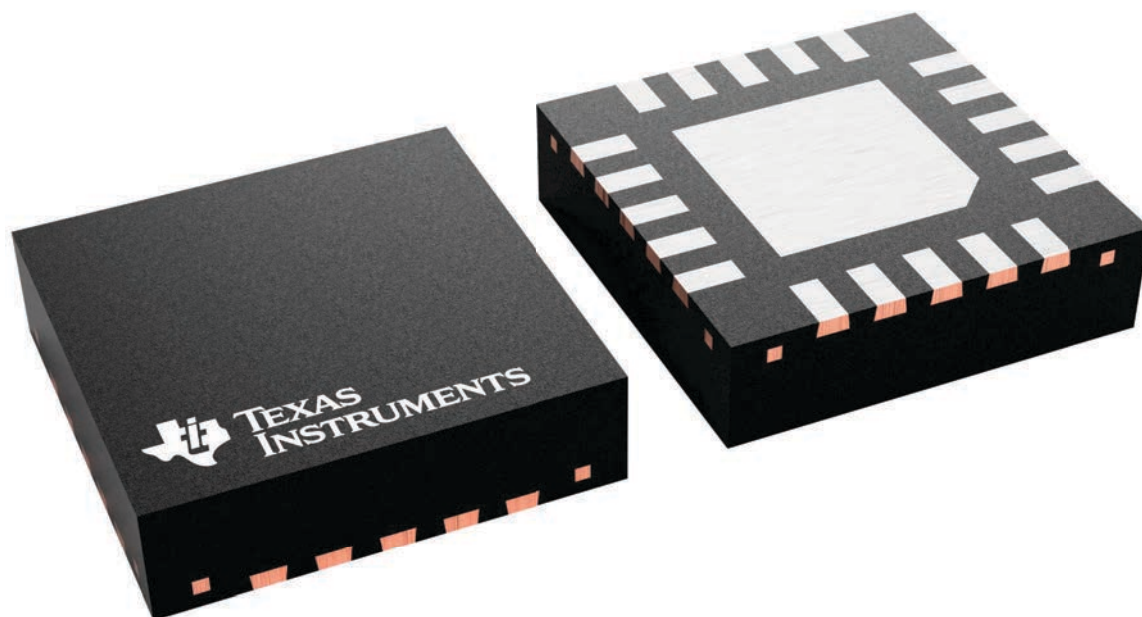

4229651/A

# RUK0020B

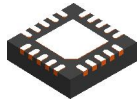

# PACKAGE OUTLINE

## WQFN - 0.8 mm max height

PLASTIC QUAD FLATPACK - NO LEAD

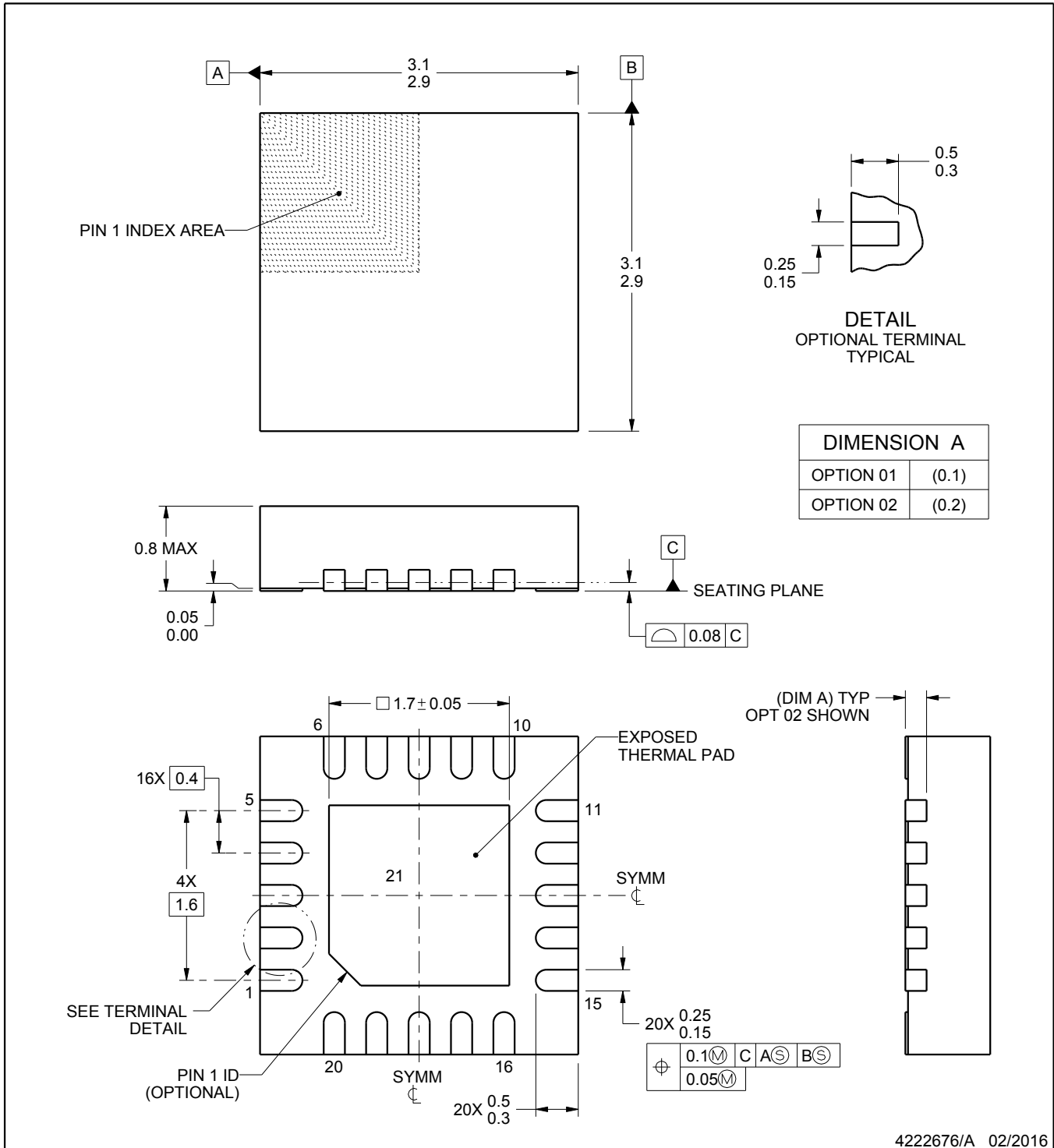

4222676/A 02/2016

**NOTES:**

1. All linear dimensions are in millimeters. Any dimensions in parenthesis are for reference only. Dimensioning and tolerancing per ASME Y14.5M.
2. This drawing is subject to change without notice.
3. The package thermal pad must be soldered to the printed circuit board for thermal and mechanical performance.

# EXAMPLE BOARD LAYOUT

RUK0020B

WQFN - 0.8 mm max height

PLASTIC QUAD FLATPACK - NO LEAD

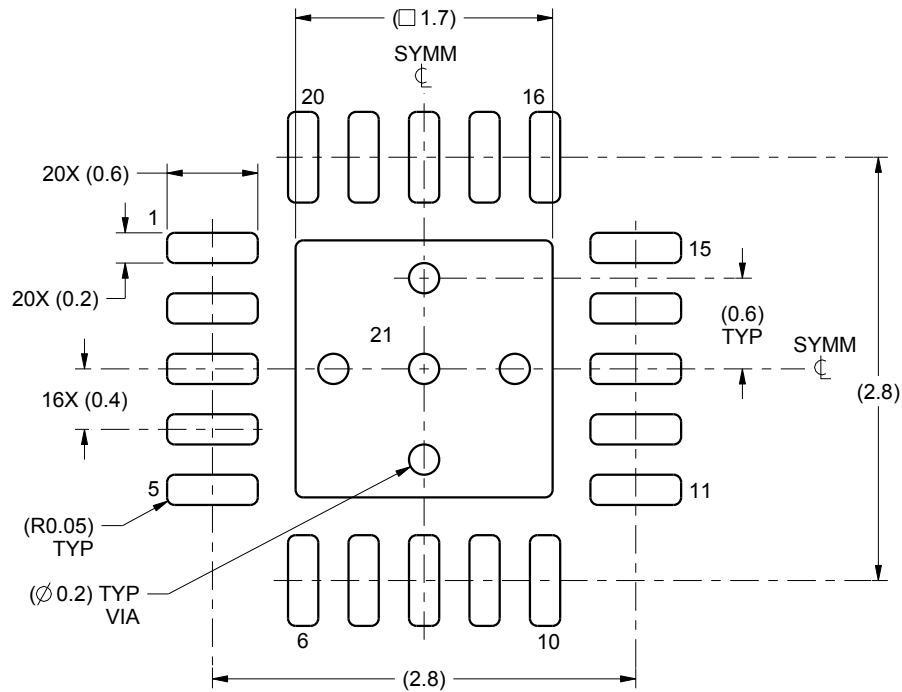

LAND PATTERN EXAMPLE  
SCALE:20X

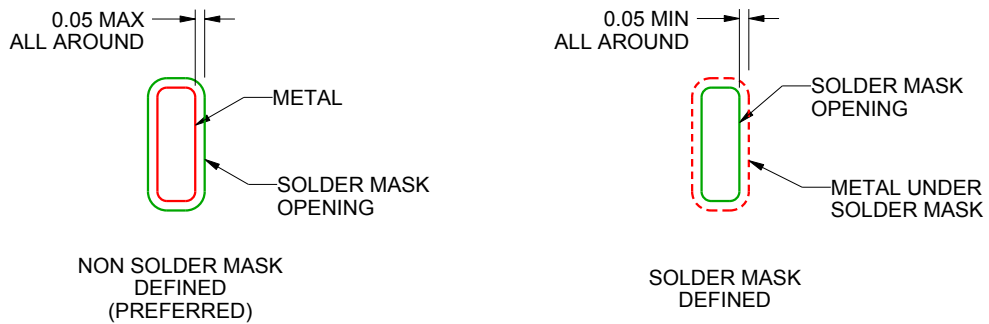

SOLDER MASK DETAILS

4222676/A 02/2016

NOTES: (continued)

4. This package is designed to be soldered to a thermal pad on the board. For more information, see Texas Instruments literature number SLUA271 ([www.ti.com/lit/sluea271](http://www.ti.com/lit/sluea271)).
5. Vias are optional depending on application, refer to device data sheet. If any vias are implemented, refer to their locations shown on this view. It is recommended that vias under paste be filled, plugged or tented.

# EXAMPLE STENCIL DESIGN

RUK0020B

WQFN - 0.8 mm max height

PLASTIC QUAD FLATPACK - NO LEAD

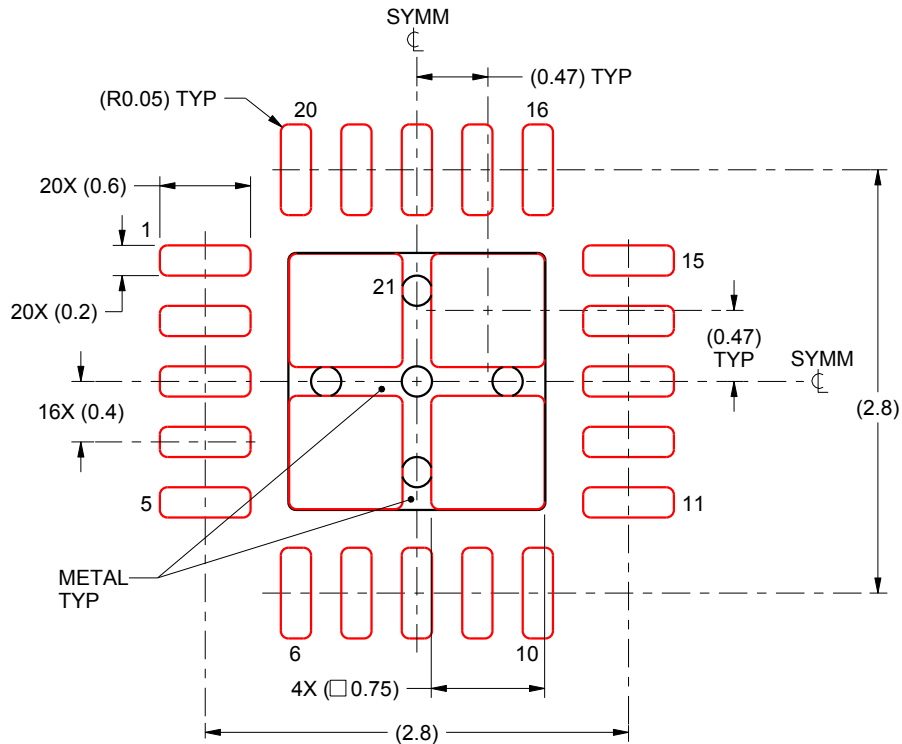

## SOLDER PASTE EXAMPLE BASED ON 0.1 mm THICK STENCIL

EXPOSED PAD 21:  
78% PRINTED SOLDER COVERAGE BY AREA UNDER PACKAGE  
SCALE:20X

4222676/A 02/2016

NOTES: (continued)

6. Laser cutting apertures with trapezoidal walls and rounded corners may offer better paste release. IPC-7525 may have alternate design recommendations.

## 重要声明和免责声明

TI“按原样”提供技术和可靠性数据（包括数据表）、设计资源（包括参考设计）、应用或其他设计建议、网络工具、安全信息和其他资源，不保证没有瑕疵且不做任何明示或暗示的担保，包括但不限于对适销性、某特定用途方面的适用性或不侵犯任何第三方知识产权的暗示担保。

这些资源可供使用 TI 产品进行设计的熟练开发人员使用。您将自行承担以下全部责任：(1) 针对您的应用选择合适的 TI 产品，(2) 设计、验证并测试您的应用，(3) 确保您的应用满足相应标准以及任何其他功能安全、信息安全、监管或其他要求。

这些资源如有变更，恕不另行通知。TI 授权您仅可将这些资源用于研发本资源所述的 TI 产品的应用。严禁对这些资源进行其他复制或展示。您无权使用任何其他 TI 知识产权或任何第三方知识产权。您应全额赔偿因在这些资源的使用中对 TI 及其代表造成的任何索赔、损害、成本、损失和债务，TI 对此概不负责。

TI 提供的产品受 [TI 的销售条款](#) 或 [ti.com](#) 上其他适用条款/TI 产品随附的其他适用条款的约束。TI 提供这些资源并不会扩展或以其他方式更改 TI 针对 TI 产品发布的适用的担保或担保免责声明。

TI 反对并拒绝您可能提出的任何其他或不同的条款。

邮寄地址：Texas Instruments, Post Office Box 655303, Dallas, Texas 75265

Copyright © 2023，德州仪器 (TI) 公司