

Revision History				
Rev	ECN #	Approved Date	Approved by	Notes
E1	N/A	N/A	GM	Original engineering release.
A	N/A	Oct. 17, 2024	GM	<ul style="list-style-type: none"> - Changed default boot mode to 11b - Changed C97 part number - Changed internal VREF connection on S3/S4 - Changed FSI connections on J5 - Removed tracking feature from U7 - Added soft start capacitor to U7 - Changed filtering scheme for ADC external reference

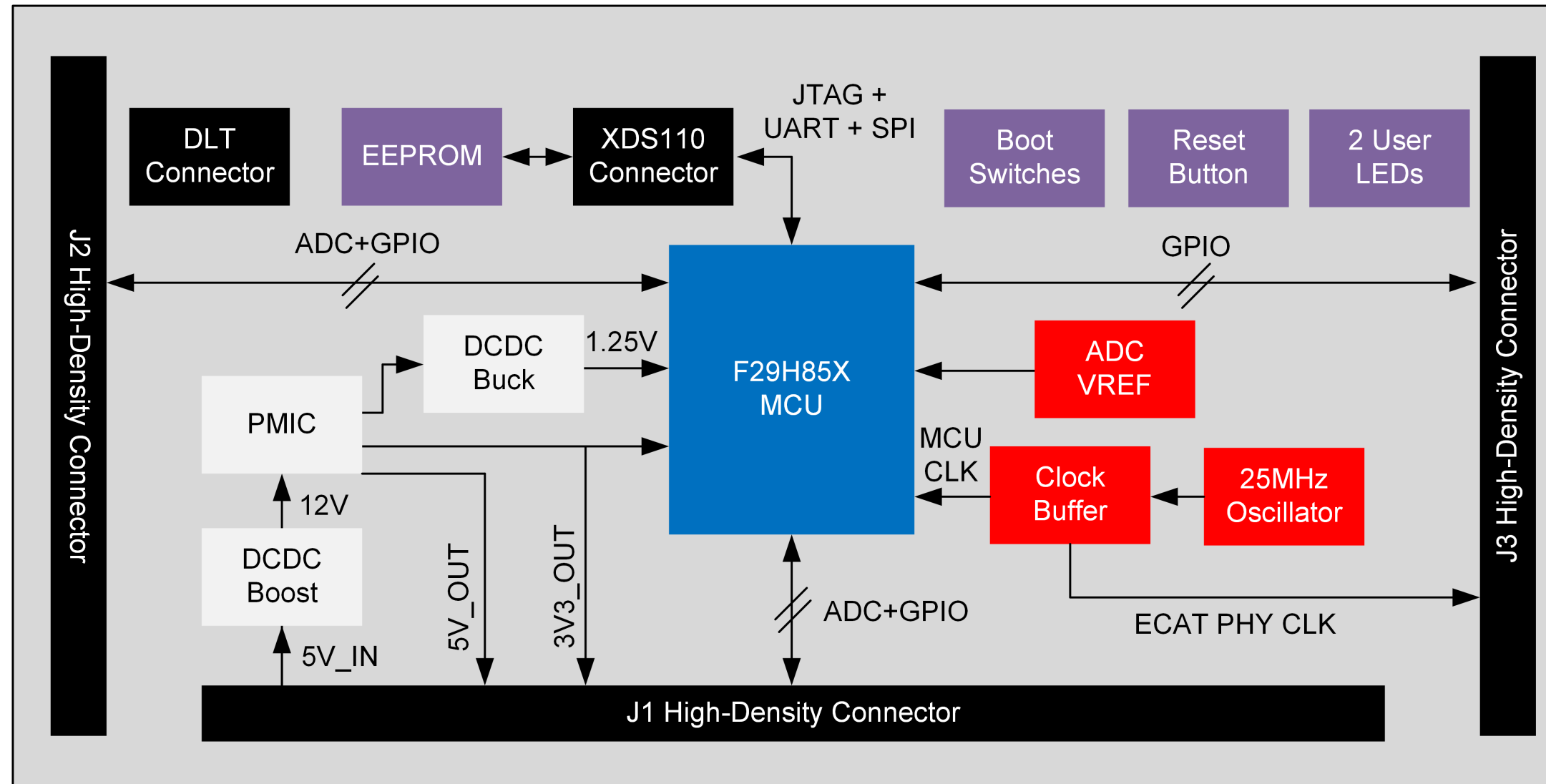

Texas Instruments and/or its licensors do not warrant the accuracy or completeness of this specification or any information contained therein. Texas Instruments and/or its licensors do not warrant that this design will meet the specifications, will be suitable for your application or fit for any particular purpose, or will operate in an implementation. Texas Instruments and/or its licensors do not warrant that the design is production worthy. You should completely validate and test your design implementation to confirm the system functionality for your application.

Orderable: F29H85X-SOM-EVM	Designed for: Public Release	Mod. Date: 10/23/2024
TID #: N/A	Project Title: F29H85x controlSOM EVM	
Number: MCU144	Rev: A	Sheet Title: Block Diagram
SVN Rev: Version control disabled	Assembly Variant: 001	Sheet: 1 of 8
Drawn By: Gustavo Martinez	File: MCU144A_Coversheet.SchDoc	Size: B
Engineer: Gustavo Martinez	Contact: http://www.ti.com/support	

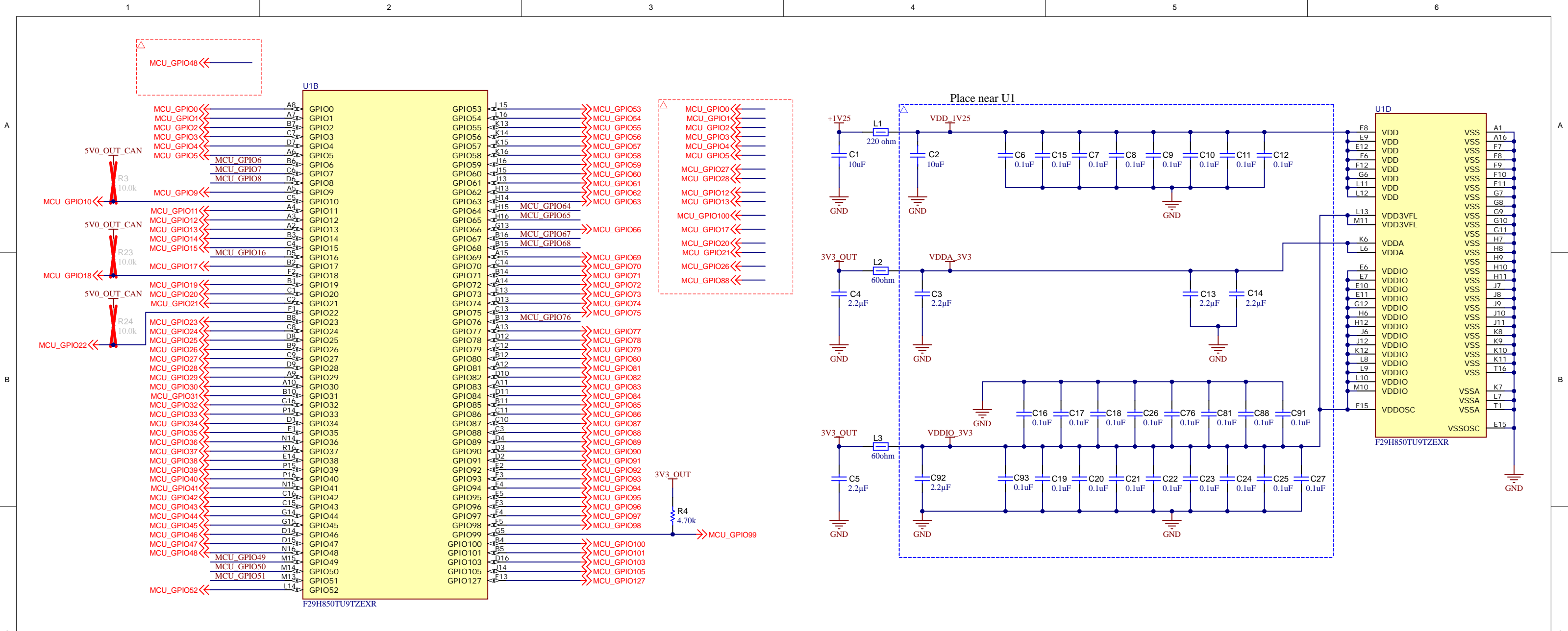

EtherCAT / MCAN-A Boot Selection

Mode	Resistor Configuration
EtherCAT support*	Populate R25/R27 and R29/R54 with 0-ohm resistor, remove R26/R45.
MCAN-A boot support	Populate R26/R45 with 0-ohm resistor, remove R25/R27 and R29/R54.

*Default

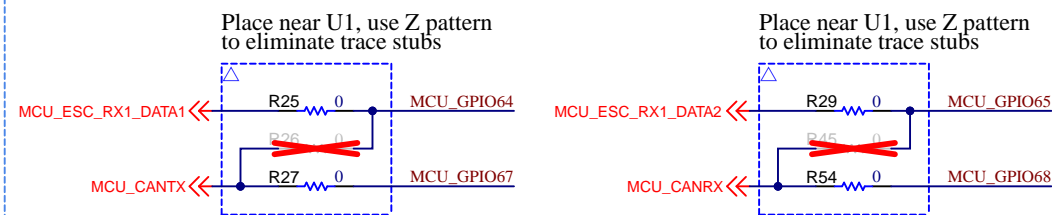

FSI Baseboard / DLT Selection

Mode	Resistor Configuration
Baseboard support*	Populate all 0-ohm resistors on SOM_GPIO nets. Remove all resistors on DLT_GPIO nets.
DLT support	Populate all 0-ohm resistors on DLT_GPIO nets. Remove all resistors on SOM_GPIO nets.

*Default

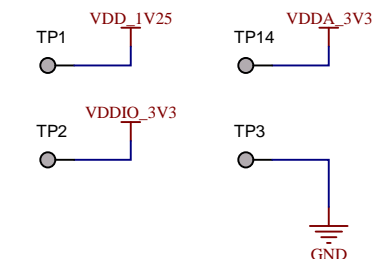
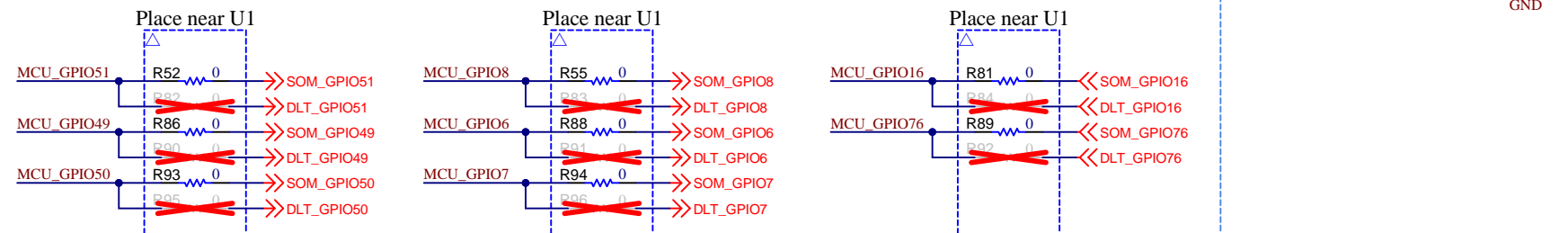

Texas Instruments and/or its licensors do not warrant the accuracy or completeness of this specification or any information contained therein. Texas Instruments and/or its licensors do not warrant that this design will meet the specifications, will be suitable for your application or fit for any particular purpose, or will operate in an implementation. Texas Instruments and/or its licensors do not warrant that the design is production worthy. You should completely validate and test your design implementation to confirm the system functionality for your application.

Orderable: F29H85X-SOM-EVM	Designed for: Public Release	Mod. Date: 7/1/2024
TID #: N/A	Project Title: F29H85x controlSOM EVM	
Number: MCU144	Rev: A	Sheet Title: GPIO and Power
SVN Rev: Version control disabled	Assembly Variant: 001	Sheet: 2 of 8
Drawn By: Gustavo Martinez	File: MCU144A_GPIO_Power.SchDoc	Size: B
Engineer: Gustavo Martinez	Contact: http://www.ti.com/support	

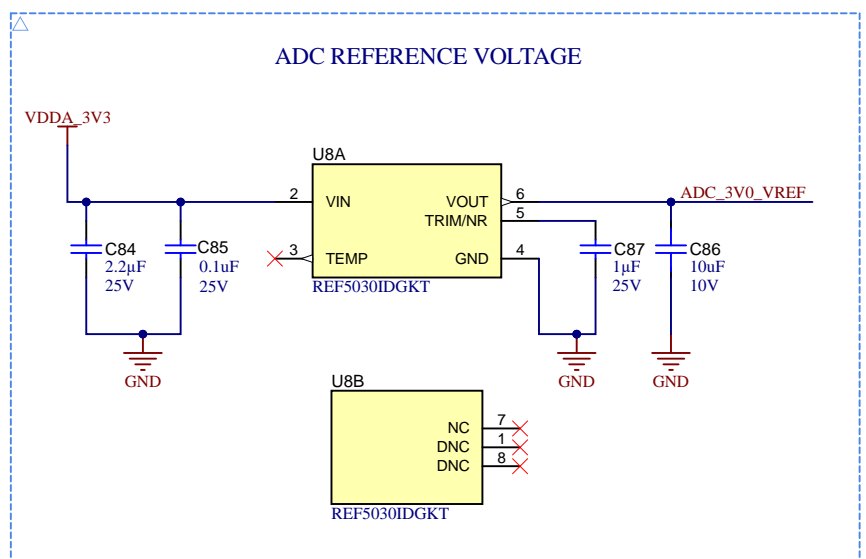
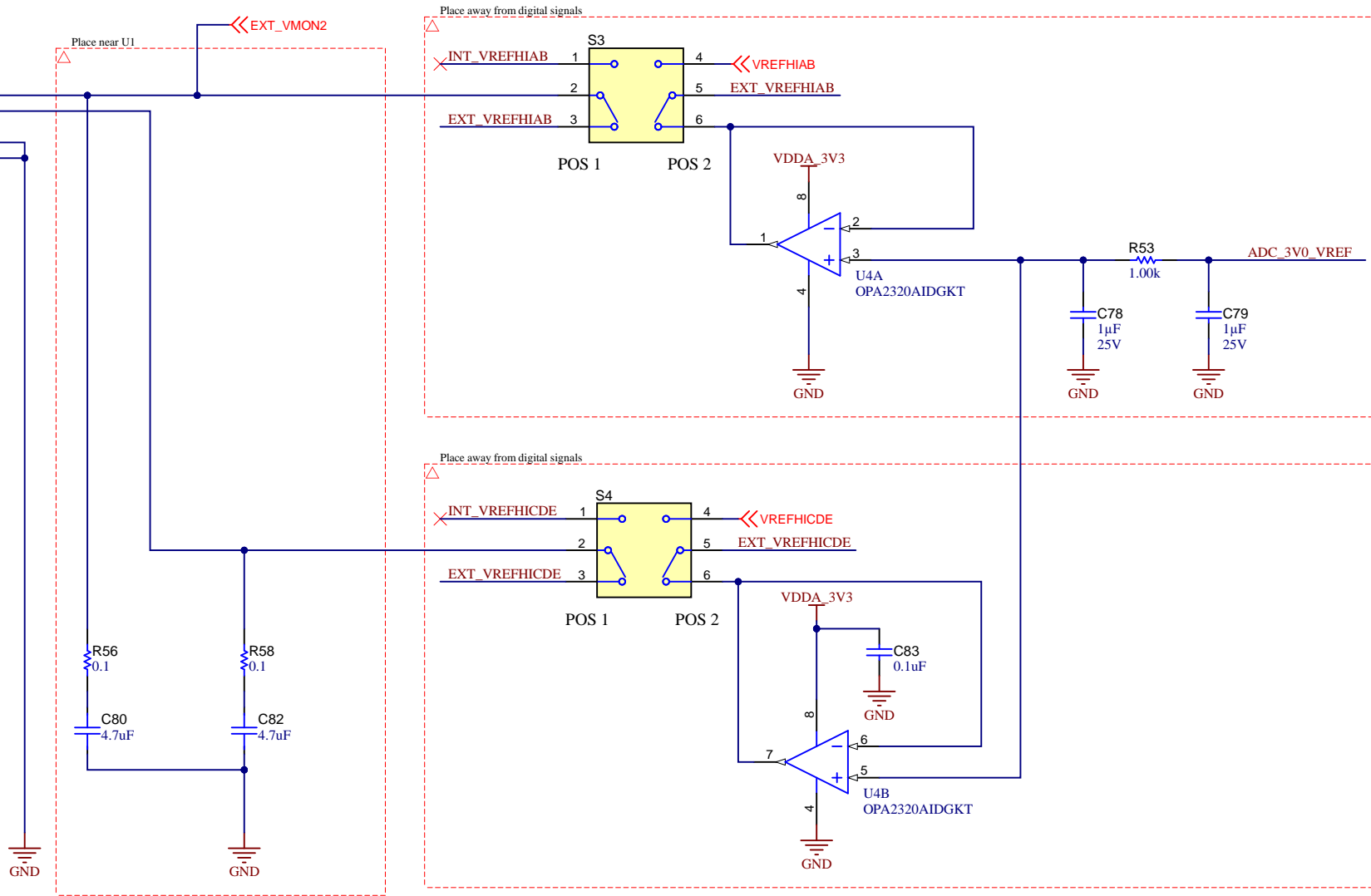
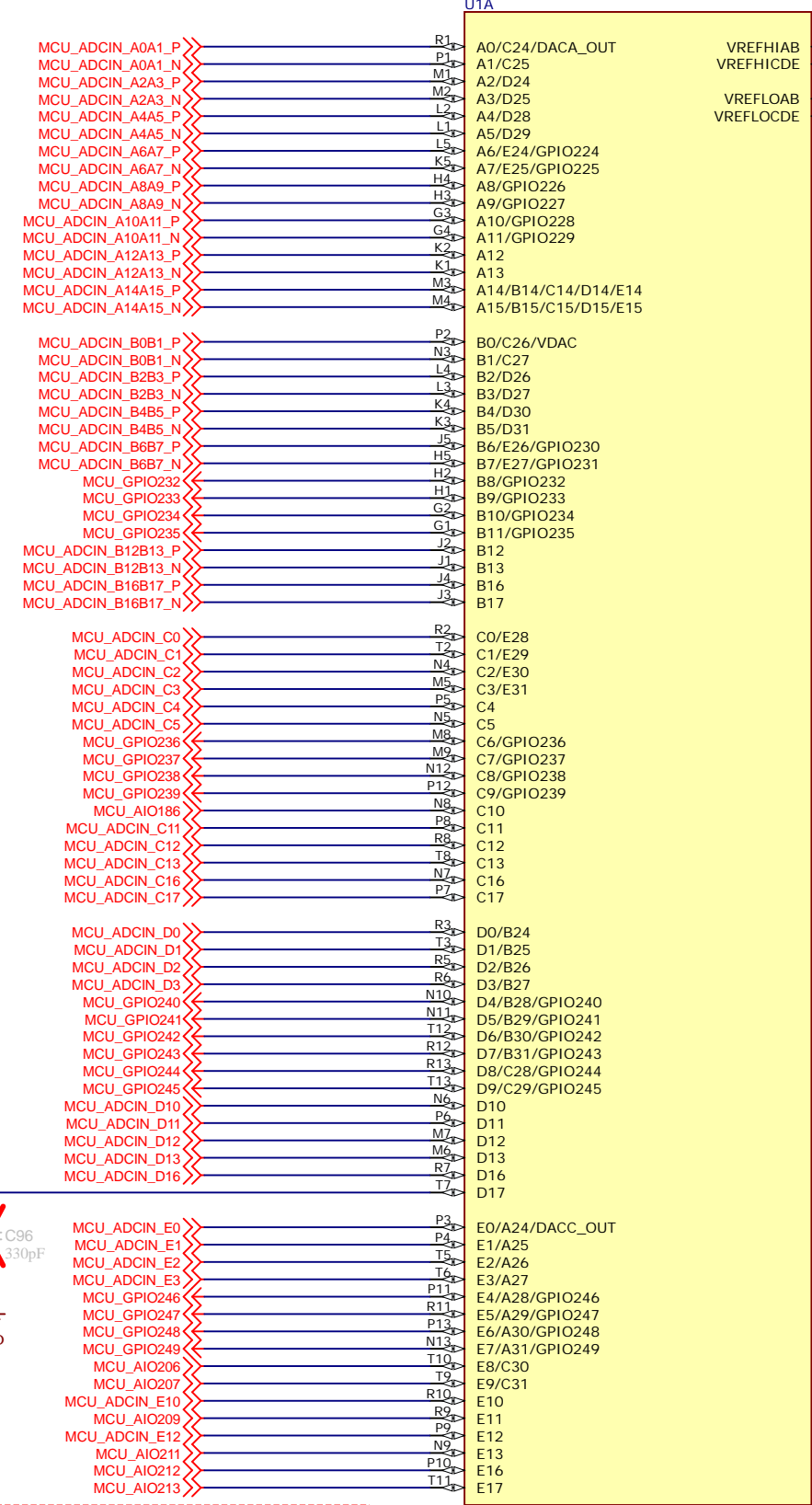
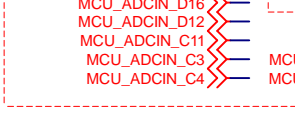
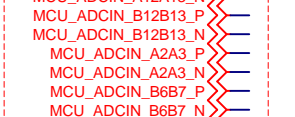
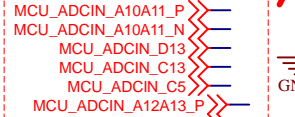
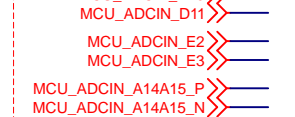
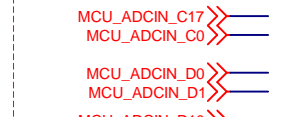
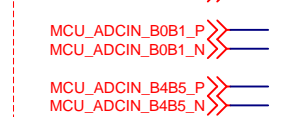
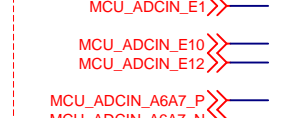
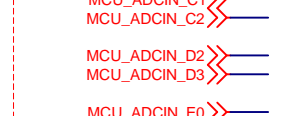
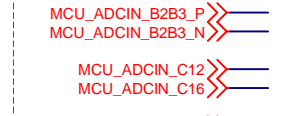
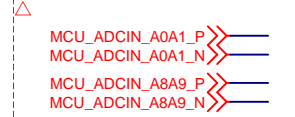
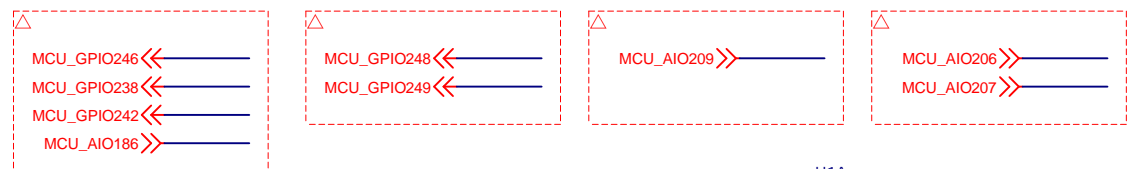

S3 (POS 1)	S3 (POS 2)	VREFHIAB Source
1-2	X	Internal VREF
2-3	4-5	External VREF (J1.VREFHIAB)
2-3	5-6	External VREF (3V0)*

*Default

S4 (POS 1)	S4 (POS 2)	VREFHICDE Source
1-2	X	Internal VREF
2-3	4-5	External VREF (J1.VREFHICDE)
2-3	5-6	External VREF (3V0)*

*Default

Texas Instruments and/or its licensors do not warrant the accuracy or completeness of this specification or any information contained therein. Texas Instruments and/or its licensors do not warrant that this design will meet the specifications, will be suitable for your application or fit for any particular purpose, or will operate in an implementation. Texas Instruments and/or its licensors do not warrant that the design is production worthy. You should completely validate and test your design implementation to confirm the system functionality for your application.

Orderable: F29H85X-SOM-EVM	Designed for: Public Release	Mod. Date: 11/2/2024
TID #: N/A	Project Title: F29H85x controlSOM EVM	
Number: MCU144	Rev: A	Sheet Title: ADC
SVN Rev: Version control disabled	Assembly Variant: 001	Sheet: 3 of 8
Drawn By: Gustavo Martinez	File: MCU144A_ADC.SchDoc	Size: B
Engineer: Gustavo Martinez	Contact: http://www.ti.com/support	



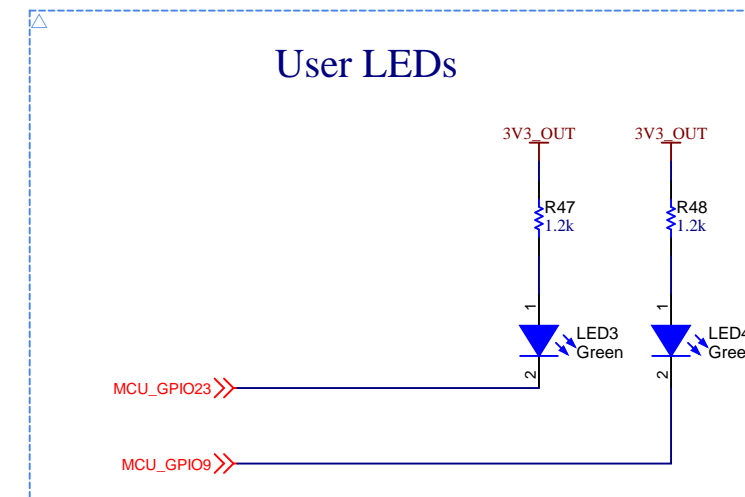
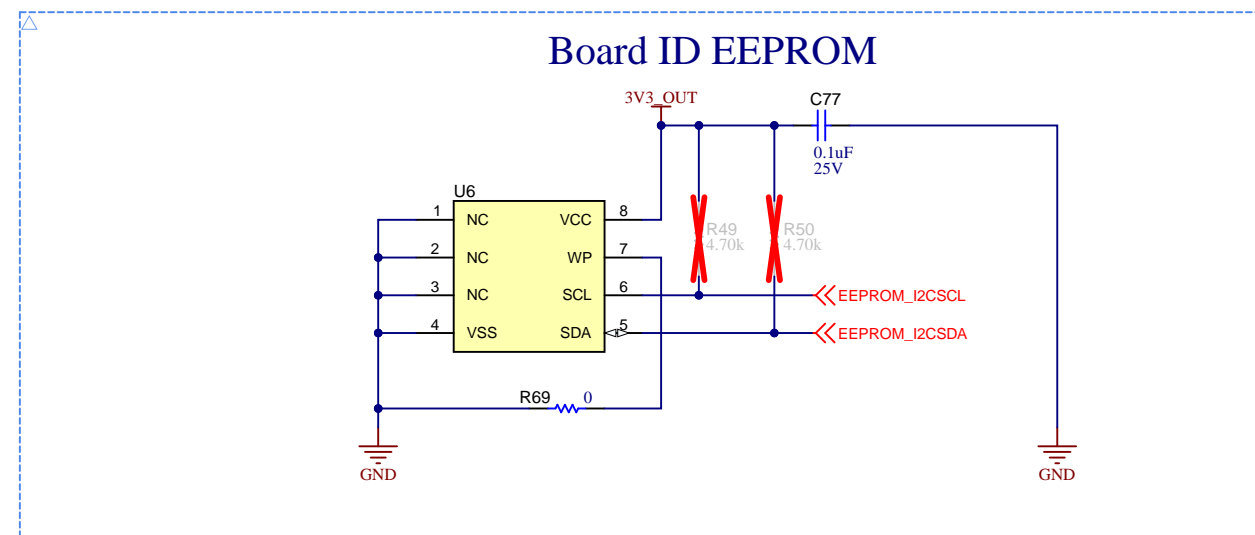
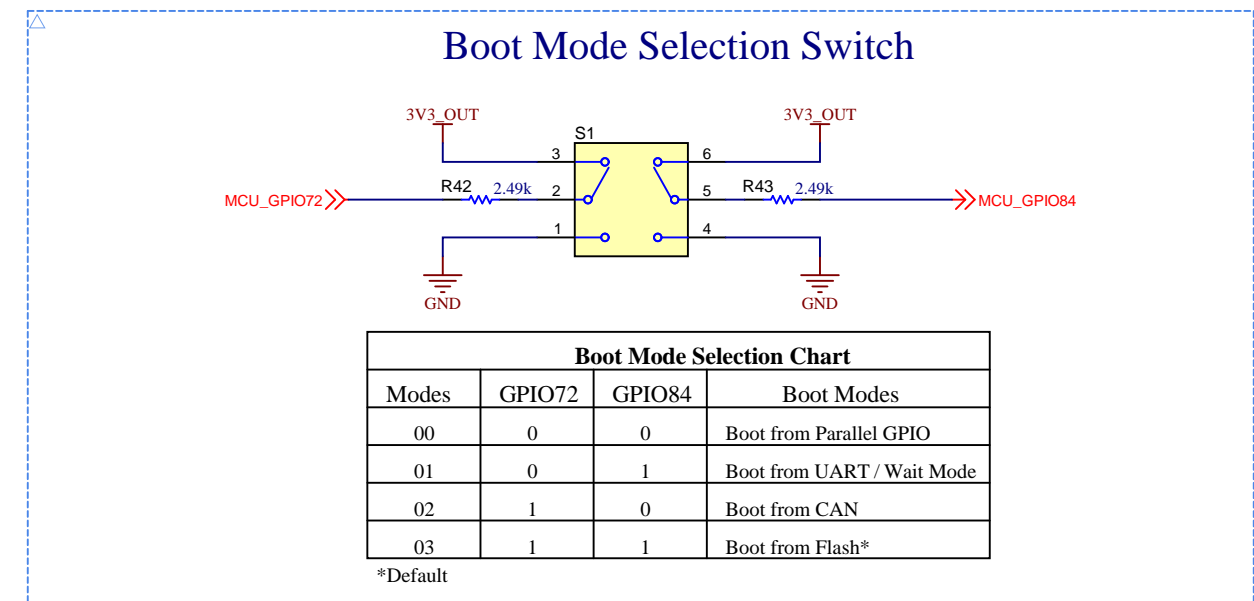
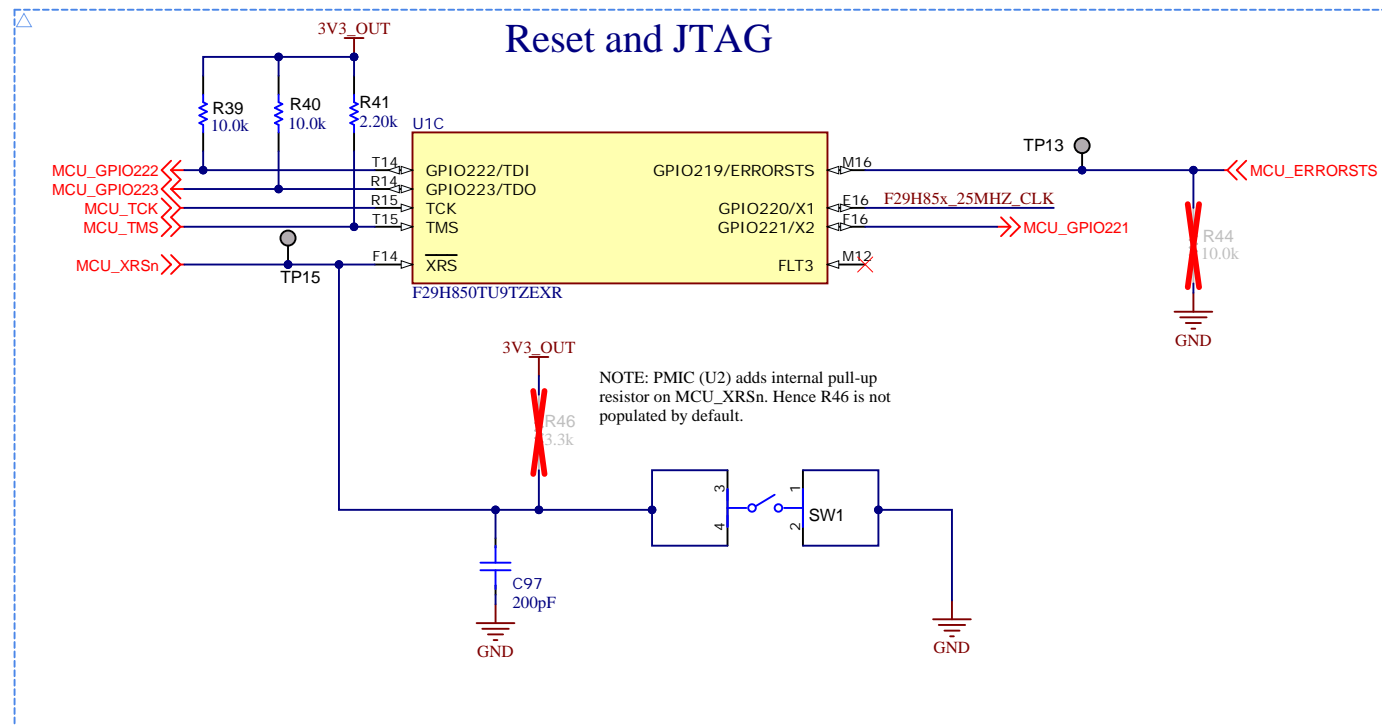
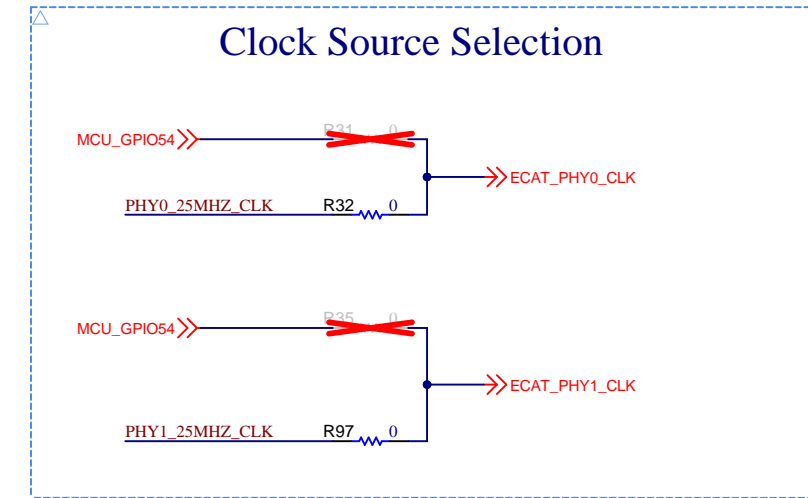
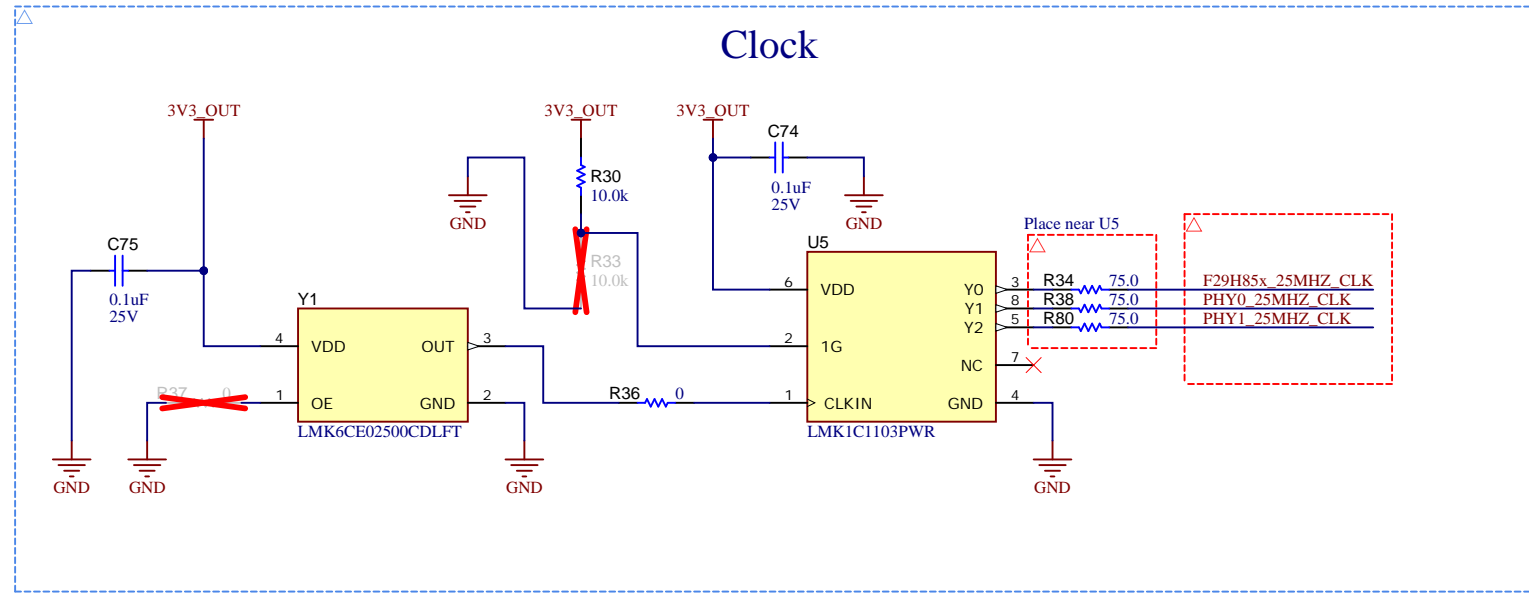

Texas Instruments and/or its licensors do not warrant the accuracy or completeness of this specification or any information contained therein. Texas Instruments and/or its licensors do not warrant that this design will meet the specifications, will be suitable for your application or fit for any particular purpose, or will operate in an implementation. Texas Instruments and/or its licensors do not warrant that the design is production worthy. You should completely validate and test your design implementation to confirm the system functionality for your application.

Orderable: F29H85X-SOM-EVM	Designed for: Public Release	Mod. Date: 11/2/2024
TID #: N/A	Project Title: F29H85x controlSOM EVM	
Number: MCU144	Rev: A	Sheet Title: Clock, Reset, and Boot
SVN Rev: Version control disabled	Assembly Variant: 001	Sheet: 4 of 8
Drawn By: Gustavo Martinez	File: MCU144A_Clock_Reset_Boot.SchDoc	Size: B
Engineer: Gustavo Martinez	Contact: http://www.ti.com/support	

TPS653860 PMIC

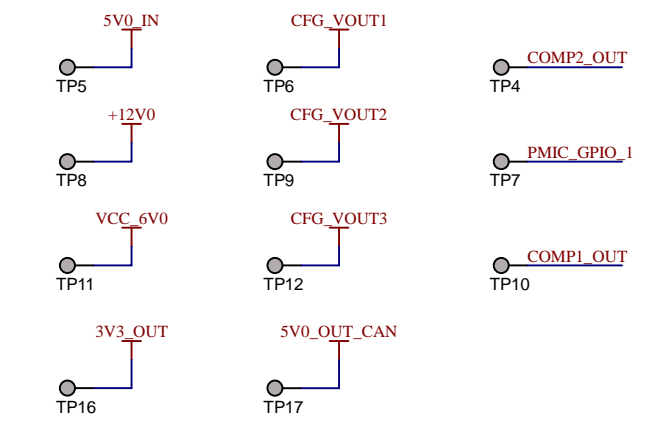
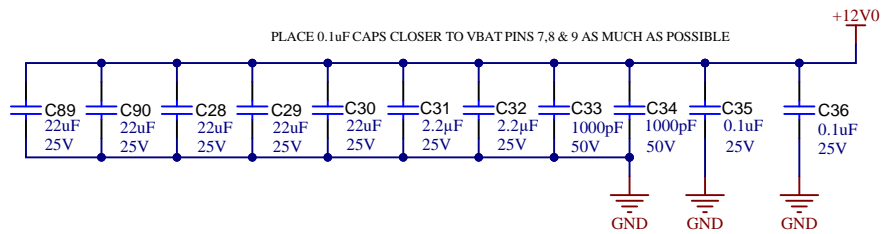
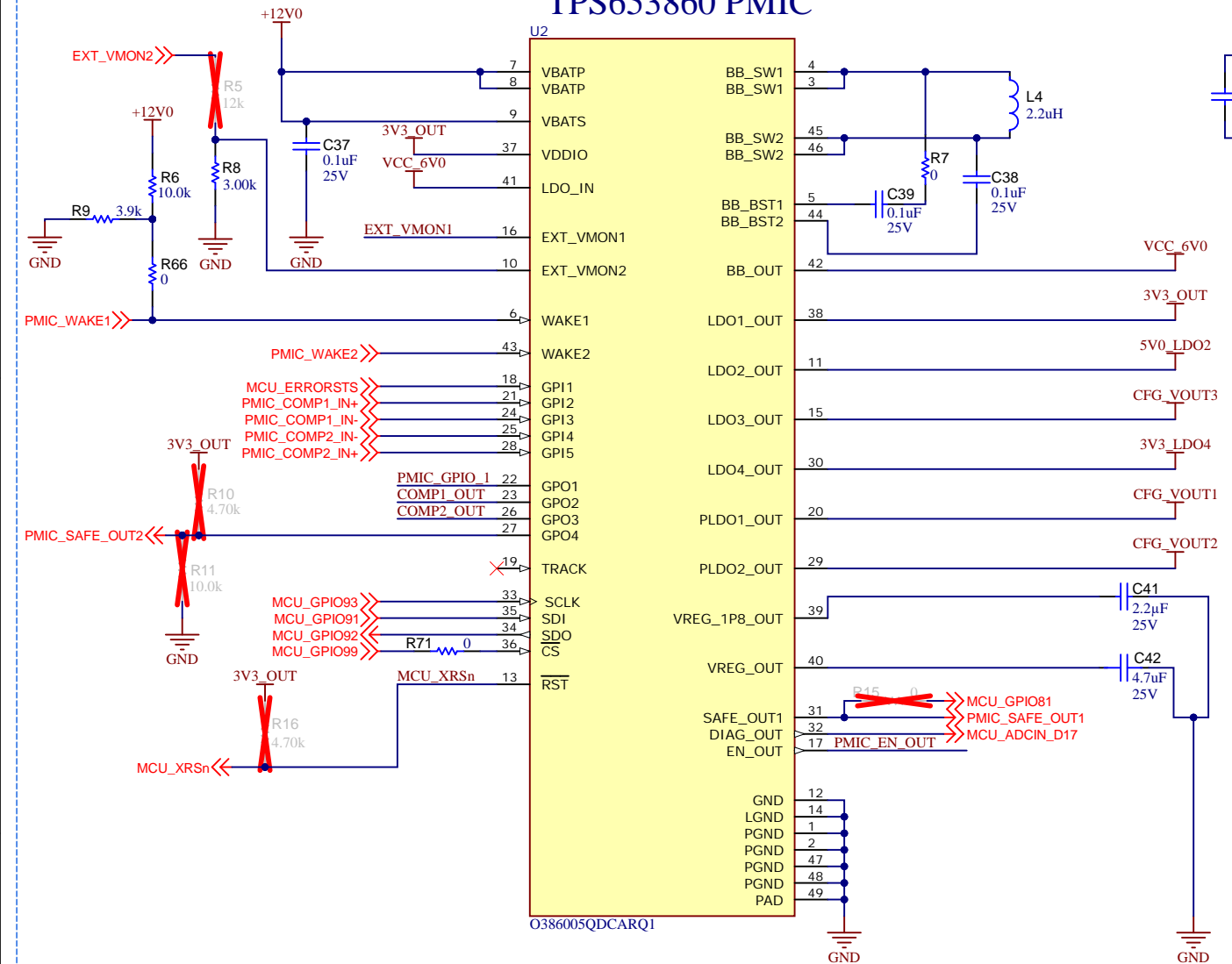

BOOST CONVERTER - 12V

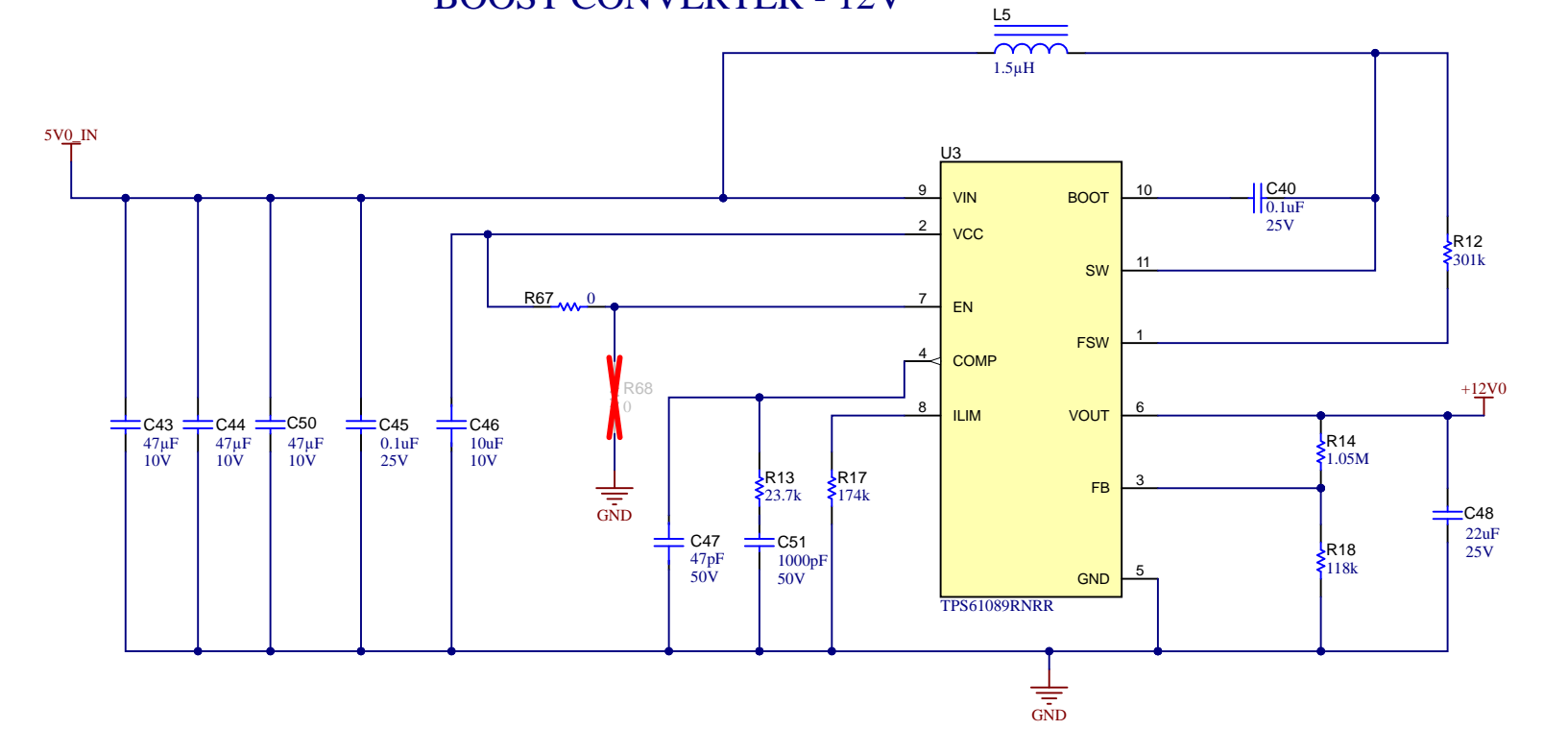

BUCK CONVERTER - 1V25

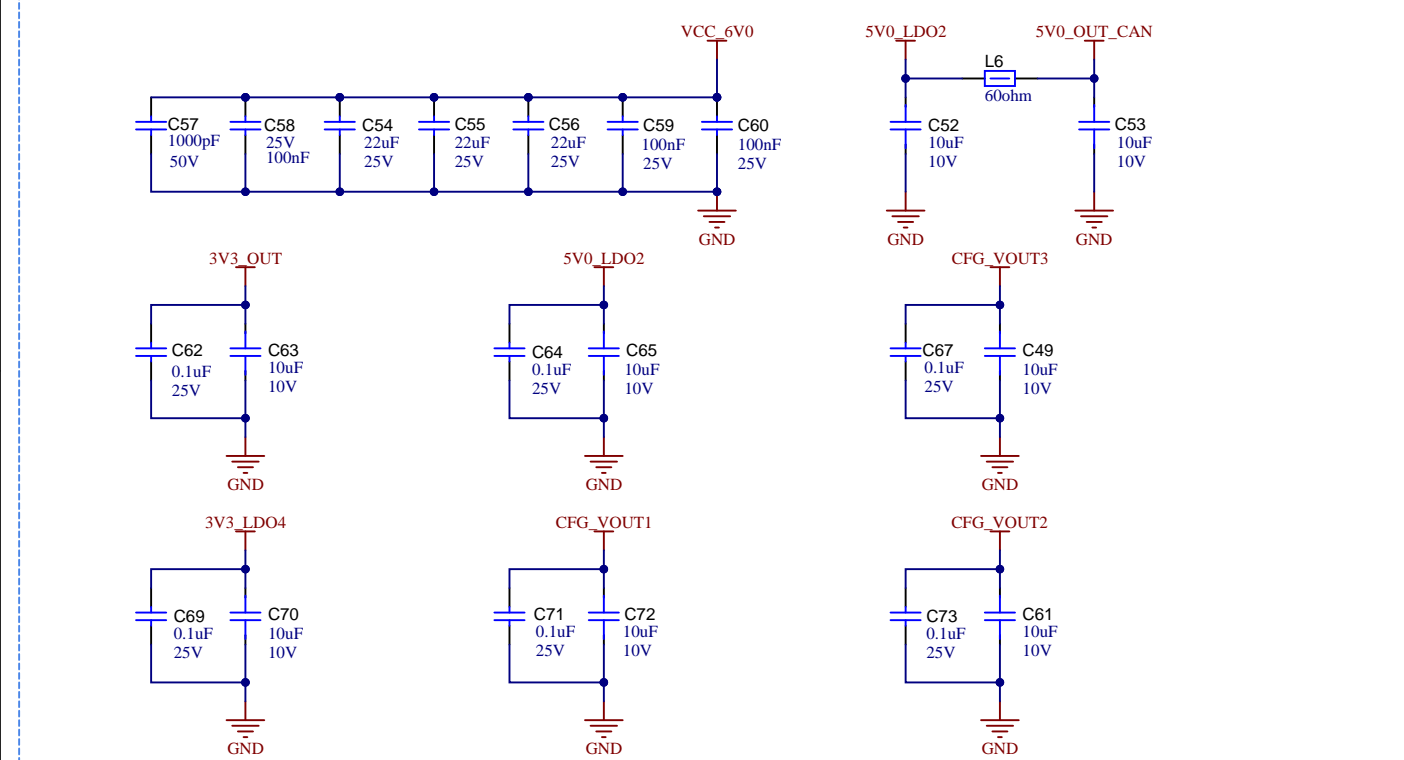
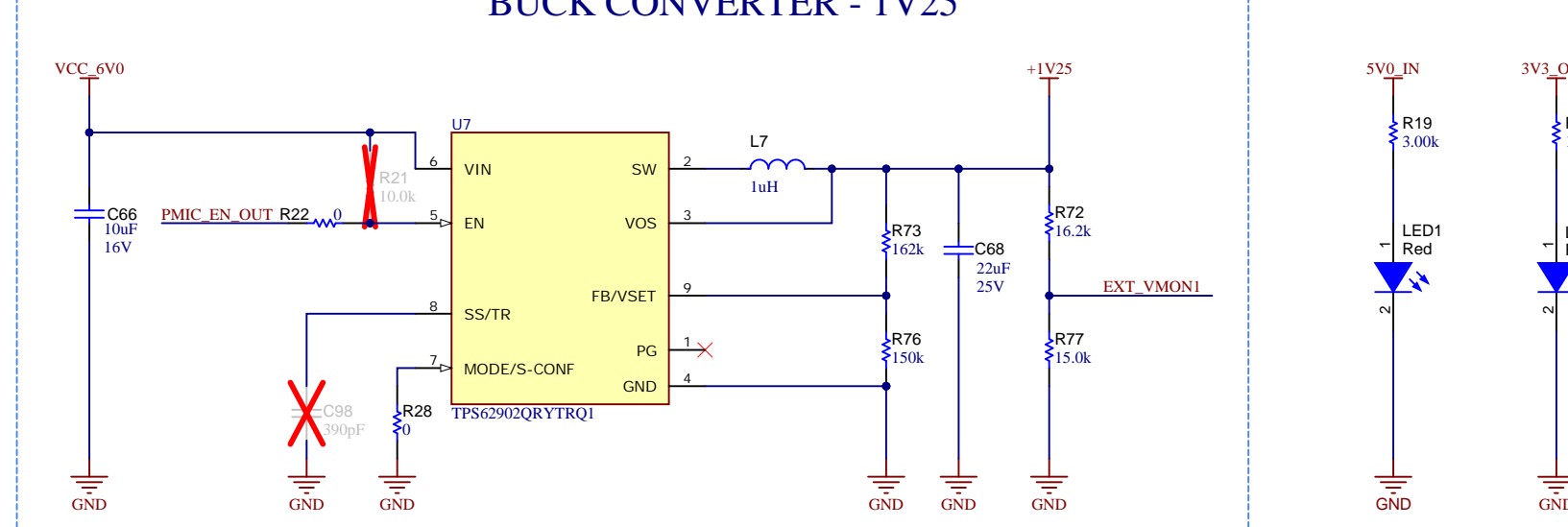

Texas Instruments and/or its licensors do not warrant the accuracy or completeness of this specification or any information contained therein. Texas Instruments and/or its licensors do not warrant that this design will meet the specifications, will be suitable for your application or fit for any particular purpose, or will operate in an implementation. Texas Instruments and/or its licensors do not warrant that the design is production worthy. You should completely validate and test your design implementation to confirm the system functionality for your application.

Orderable: F29H85X-SOM-EVM	Designed for: Public Release	Mod. Date: 11/2/2024
TID #: N/A	Project Title: F29H85x controlSOM EVM	
Number: MCU144	Rev: A	Sheet Title: controlSOM Power
SVN Rev: Version control disabled	Assembly Variant: 001	Sheet: 5 of 8
Drawn By: Gustavo Martinez	File: MCU144A_SOM_Power.SchDoc	Size: B
Engineer: Gustavo Martinez	Contact: http://www.ti.com/support	



High Density Connector J1

High Density Connector J2

High Density Connector J3

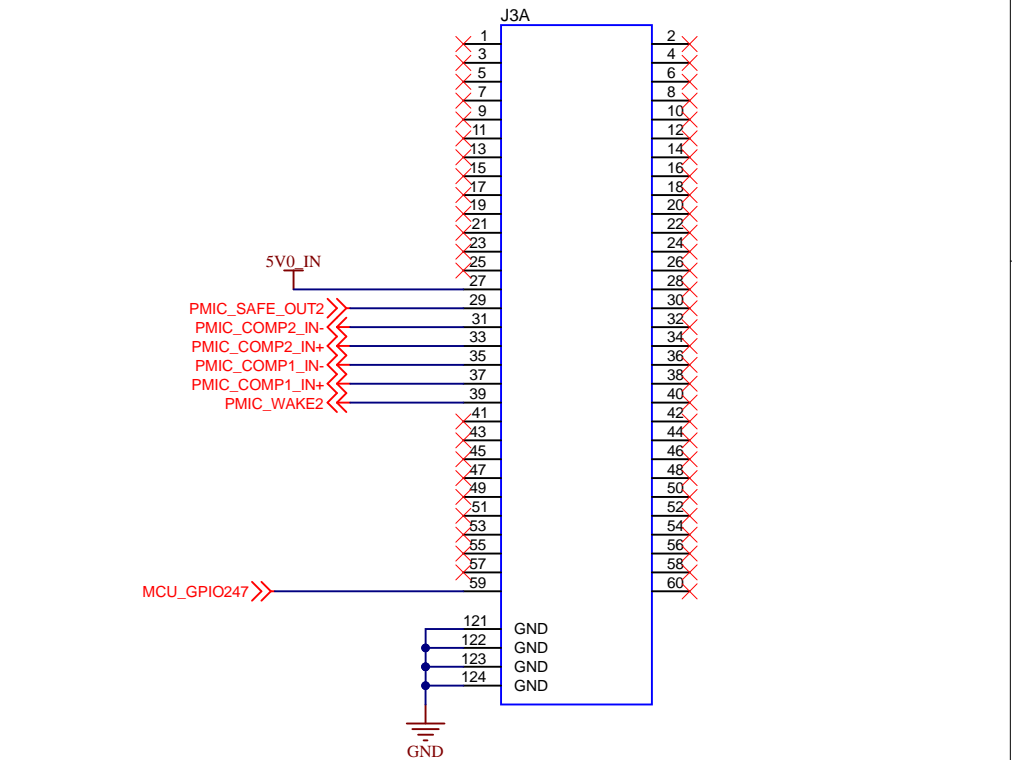
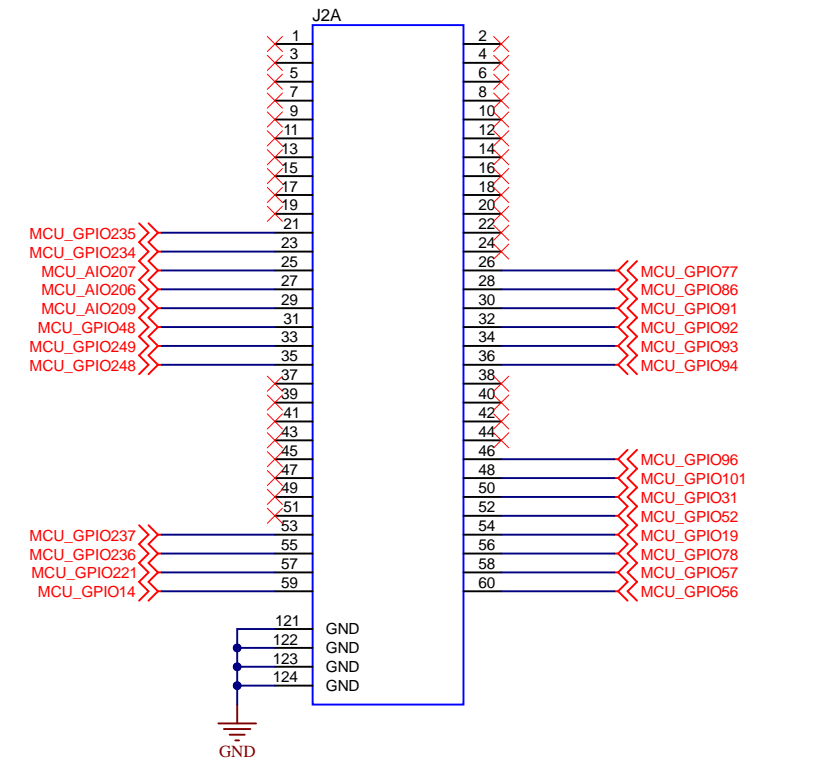
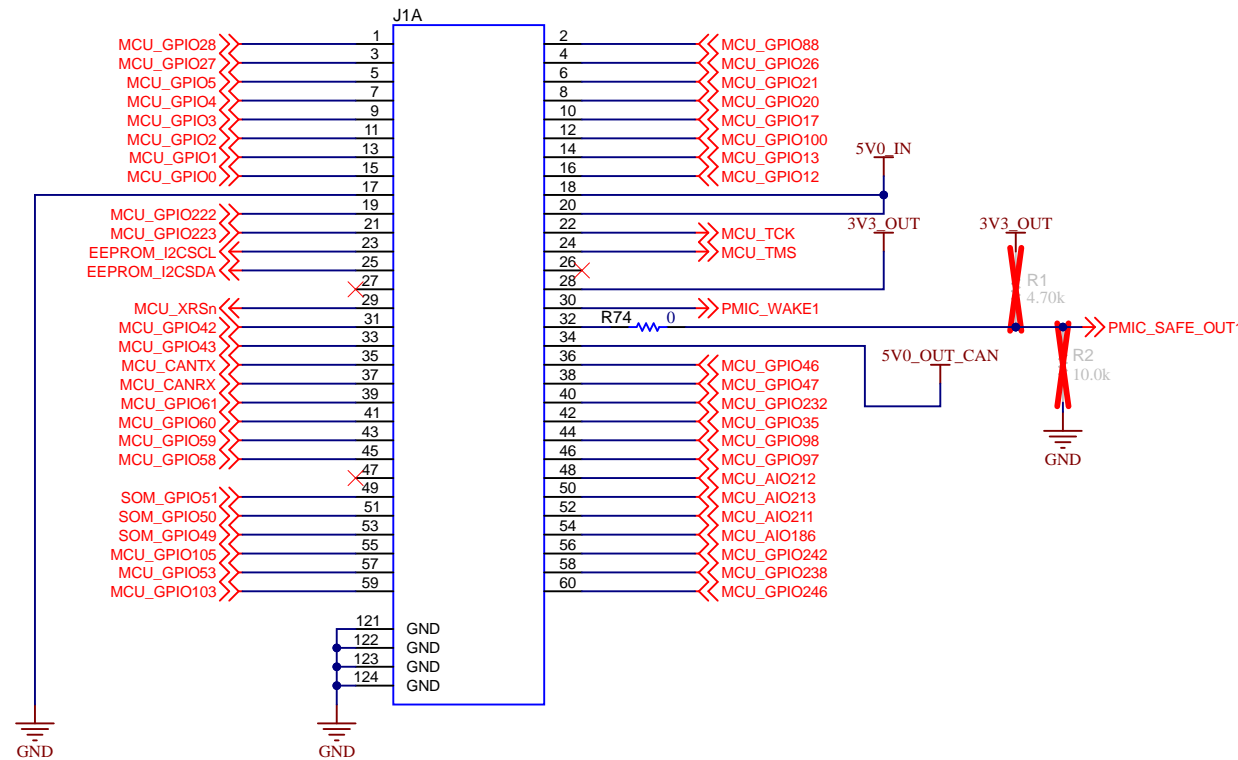

Data Logging and Trace Connector

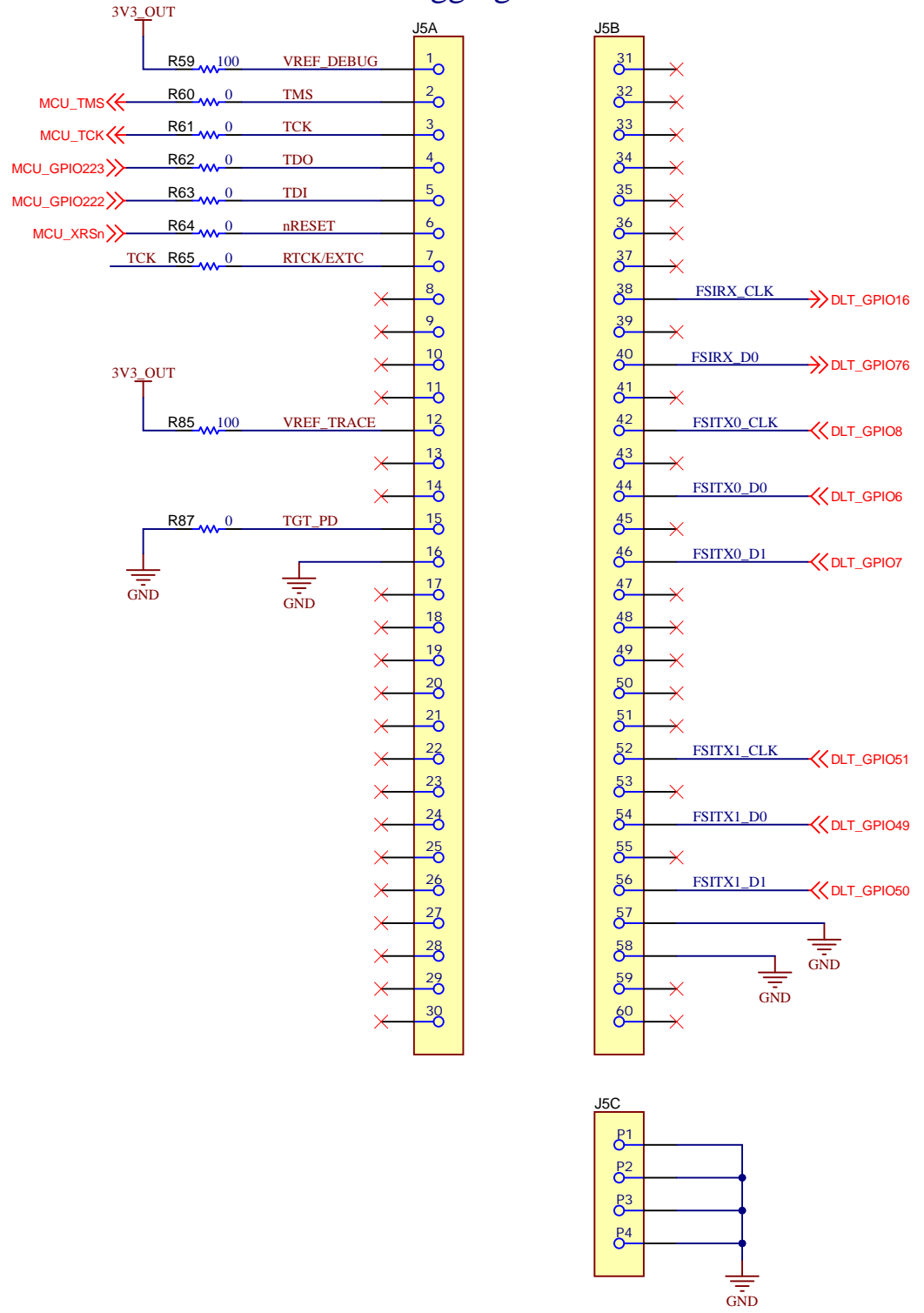

Emulator Connector

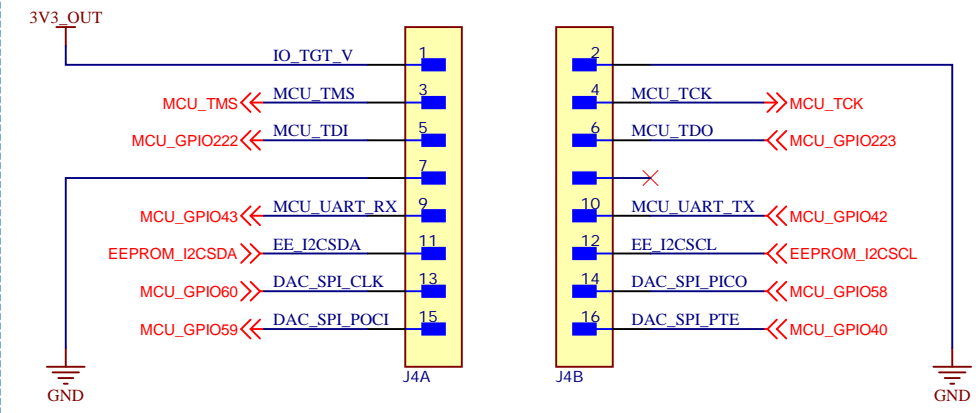

Texas Instruments and/or its licensors do not warrant the accuracy or completeness of this specification or any information contained therein. Texas Instruments and/or its licensors do not warrant that this design will meet the specifications, will be suitable for your application or fit for any particular purpose, or will operate in an implementation. Texas Instruments and/or its licensors do not warrant that the design is production worthy. You should completely validate and test your design implementation to confirm the system functionality for your application.



PCB Number: MCU144
PCB Rev: A

PCB LOGO
Texas Instruments

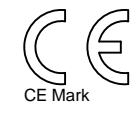

PCB LOGO
FCC disclaimer

PCB LOGO
WEEE logo

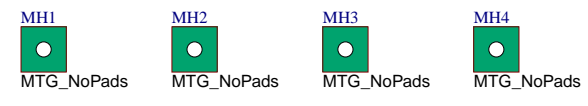

ZZ1
Label Assembly Note
This Assembly Note is for PCB labels only

ZZ2
Assembly Note
These assemblies are ESD sensitive, ESD precautions shall be observed.

ZZ3
Assembly Note
These assemblies must be clean and free from flux and all contaminants. Use of no clean flux is not acceptable.

ZZ4
Assembly Note
These assemblies must comply with workmanship standards IPC-A-610 Class 2, unless otherwise specified.

Texas Instruments and/or its licensors do not warrant the accuracy or completeness of this specification or any information contained therein. Texas Instruments and/or its licensors do not warrant that this design will meet the specifications, will be suitable for your application or fit for any particular purpose, or will operate in an implementation. Texas Instruments and/or its licensors do not warrant that the design is production worthy. You should completely validate and test your design implementation to confirm the system functionality for your application.

Orderable: F29H85X-SOM-EVM	Designed for: Public Release	Mod. Date: 7/1/2024	
TID #: N/A	Project Title: F29H85x controlSOM EVM		
Number: MCU144	Rev: A	Sheet Title: EVM Hardware	
SVN Rev: Version control disabled	Assembly Variant: 001	Sheet: 8 of 8	
Drawn By: Gustavo Martinez	File: MCU144A_EVM_Hardware.SchDoc	Size: B	
Engineer: Gustavo Martinez	Contact: http://www.ti.com/support		http://www.ti.com © Texas Instruments 2024

IMPORTANT NOTICE AND DISCLAIMER

TI PROVIDES TECHNICAL AND RELIABILITY DATA (INCLUDING DATA SHEETS), DESIGN RESOURCES (INCLUDING REFERENCE DESIGNS), APPLICATION OR OTHER DESIGN ADVICE, WEB TOOLS, SAFETY INFORMATION, AND OTHER RESOURCES "AS IS" AND WITH ALL FAULTS, AND DISCLAIMS ALL WARRANTIES, EXPRESS AND IMPLIED, INCLUDING WITHOUT LIMITATION ANY IMPLIED WARRANTIES OF MERCHANTABILITY, FITNESS FOR A PARTICULAR PURPOSE OR NON-INFRINGEMENT OF THIRD PARTY INTELLECTUAL PROPERTY RIGHTS.

These resources are intended for skilled developers designing with TI products. You are solely responsible for (1) selecting the appropriate TI products for your application, (2) designing, validating and testing your application, and (3) ensuring your application meets applicable standards, and any other safety, security, regulatory or other requirements.

These resources are subject to change without notice. TI grants you permission to use these resources only for development of an application that uses the TI products described in the resource. Other reproduction and display of these resources is prohibited. No license is granted to any other TI intellectual property right or to any third party intellectual property right. TI disclaims responsibility for, and you will fully indemnify TI and its representatives against, any claims, damages, costs, losses, and liabilities arising out of your use of these resources.

TI's products are provided subject to [TI's Terms of Sale](#) or other applicable terms available either on [ti.com](https://www.ti.com) or provided in conjunction with such TI products. TI's provision of these resources does not expand or otherwise alter TI's applicable warranties or warranty disclaimers for TI products.

TI objects to and rejects any additional or different terms you may have proposed.

Mailing Address: Texas Instruments, Post Office Box 655303, Dallas, Texas 75265
Copyright © 2024, Texas Instruments Incorporated