

TCAN1472-Q1 車載用、フォルト保護 CAN FD トランシーバ、信号改善機能 (SIC) およびスタンバイ モード付き

1 特長

- AEC Q100: 車載アプリケーション認定済み
- 機能安全対応
- 付則 A の CAN SIC 仕様を含む、ISO 11898-2:2024 規格の要件に適合
- Classical CAN および最大 8Mbps の CAN FD
 - 複雑なトポロジでのリングング効果を低減することにより、バス信号をアクティブに改善
 - Classic CAN ネットワークでの使用に対する下位互換性
- V_{IO} レベル シフト対応: 1.7V~5.5V
- 動作モード
 - 通常モード
 - リモート ウェイクアップ要求をサポートする、低消費電力スタンバイ モード
- 電源非接続時のパッシブ動作
 - バスおよびロジック端子は高インピーダンス (動作中のバスまたはアプリケーションに無負荷)
 - ホットプラグ対応: バスおよび RXD 出力での電源オン/オフ時のグリッチ フリー動作
 - フローティング論理ピンと低電圧電源条件におけるデバイスの動作を定義
- 保護機能
 - バスピンの IEC ESD 保護
 - CAN バスの障害耐性: $\pm 58V$
 - V_{CC} および V_{IO} (V バージョンのみ) 電源端子の低電圧保護
 - TXD ドミナント状態タイムアウト (TXD DTO)
 - サーマル シャットダウン保護 (TSD)
- SOIC (8)、小型フットプリント SOT-23 (8)、自動光学検査 (AOI) 性能を向上させたウェットプル フランクのリードレス VSON (8) パッケージで供給

2 アプリケーション

- 車載ゲートウェイ
- 先進運転支援システム (ADAS)
- ボディ エレクトロニクスおよび照明
- ハイブリッド、電気、パワートレイン システム
- 車載インフォテインメントおよびクラスター

3 概要

TCAN1472-Q1 および TCAN1472V-Q1 は、ISO 11898-2:2024 付則 A 信号改善機能 (SIC) 仕様の物理層要件を満たす高速 CAN (Controller Area Network) SIC トランシーバです。このデバイスは、ドミナントとリセットのエッジで信号リングングを低減し、複雑なネットワーク トポロジで高いスループットを実現します。信号改善機能を活用すると、アプリケーションは複数の未終端のスタブを持つ大規模ネットワークで 2Mbps で動作または 5Mbps 以降で動作することで、CAN FD (フレキシブル データレート) の真のメリットを引き出すことができます。

これらのデバイスは、ISO11898-2:2024 の付則 A SIC 部が規定するタイミング仕様を満たしており、通常の CAN FD トランシーバと比較して、はるかに厳密なビット タイミング対称性を備えています。この結果、より大きなタイミング ウィンドウを使用して正しいビットをサンプリングし、リングングとビット歪みを本質的に持つ大きく複雑なスター ネットワークでエラー フリーの通信を実現しています。

これらのデバイスは、TCAN1046A-Q1 や TCAN1042-Q1 など、8 ピンの CAN FD トランシーバとピン互換です。

「V」接尾辞付きの TCAN1472-Q1 デバイスには、 V_{IO} ロジック電源ピン経由の内部ロジック レベル変換が搭載されており、1.8V、3.3V、5V のコントローラと直接接続できます。これらのトランシーバは低消費電力スタンバイ モードをサポートしており、ISO 11898-2:2024 に定義されたウェイクアップ パターン (WUP) に準拠した CAN バスによるリモート ウェイクアップが可能です。このデバイス ファミリーは、低電圧検出、サーマル シャットダウン (TSD)、ドライブドミナント タイムアウト (TXD DTO)、 $\pm 58V$ のバス フォルト保護などの多くの保護機能も備えています。

パッケージ情報

部品番号	パッケージ (1)	パッケージ サイズ (2)
TCAN1472-Q1	SOT-23 (DDF)	2.9mm x 1.6mm
	VSON (DRB)	3mm x 3mm
	SOIC (D)	4.9mm x 3.91mm

- (1) 詳細については、[セクション 11](#) を参照してください。
- (2) パッケージ サイズ (長さ × 幅) は公称値であり、該当する場合はピンも含まれます。



デバイス比較表

デバイス番号	バス故障保護	ピン 5 で低電圧 I/O ロジックをサポート	ピン 8 のモード選択
TCAN1472-Q1	± 58V	なし	リモート ウェイクアップ機能付き低消費電力スタンバイモード
TCAN1472V-Q1	± 58V	あり	

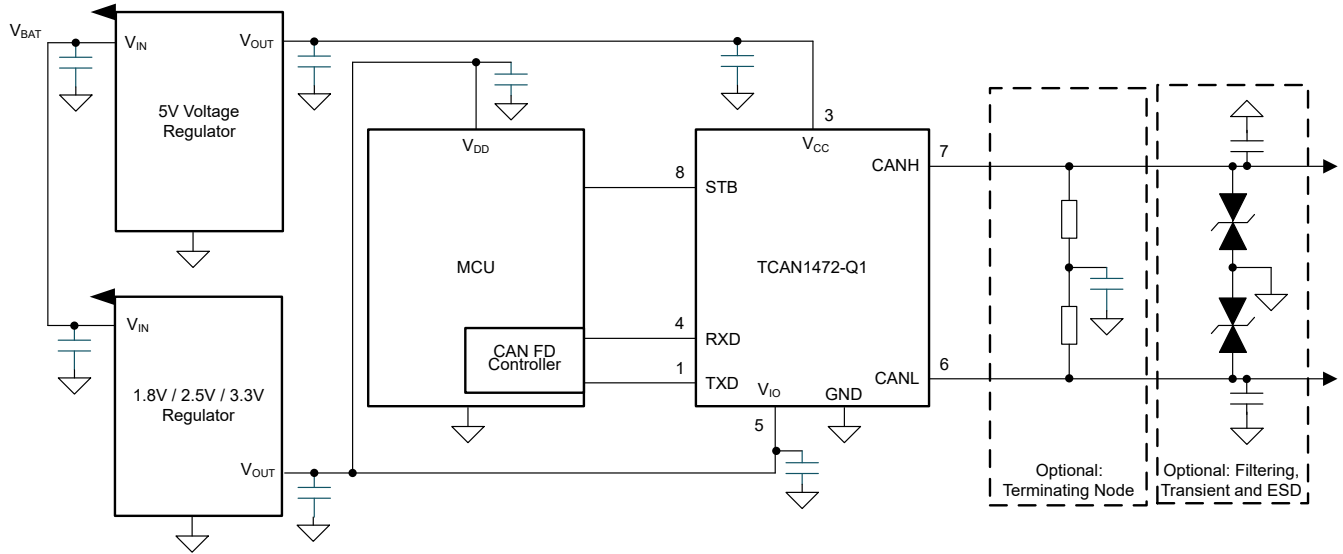

概略ブロック図

ADVANCE INFORMATION

Table of Contents

1 特長	1	7.3 Feature Description.....	17
2 アプリケーション	1	7.4 Device Functional Modes.....	21
3 概要	1	8 Application and Implementation	23
4 Pin Configurations and Functions	4	8.1 Application Information.....	23
5 Specifications	5	8.2 Typical Application.....	23
5.1 Absolute Maximum Ratings.....	5	8.3 System Examples.....	26
5.2 ESD Ratings	5	8.4 Power Supply Recommendations.....	26
5.3 ESD Ratings, IEC Transients.....	5	8.5 Layout.....	27
5.4 Recommended Operating Conditions.....	6	9 Device and Documentation Support	28
5.5 Thermal Characteristics.....	6	9.1 Receiving Notification of Documentation Updates....	28
5.6 Supply Characteristics.....	6	9.2 サポート・リソース.....	28
5.7 Dissipation Ratings.....	7	9.3 Trademarks.....	28
5.8 Electrical Characteristics.....	7	9.4 静電気放電に関する注意事項.....	28
5.9 Switching Characteristics.....	9	9.5 用語集.....	28
6 Parameter Measurement Information	12	10 Revision History	28
7 Detailed Description	15	11 Mechanical, Packaging, and Orderable Information	28
7.1 Overview.....	15	11.1 Tape and Reel Information.....	29
7.2 Functional Block Diagram.....	16		

4 Pin Configurations and Functions



図 4-1. SOIC (D) and SOT-23 (DDF) Package, 8 Pin (Top View)



図 4-2. VSON (DRB) Package, 8 Pin (Top View)

表 4-1. Pin Functions

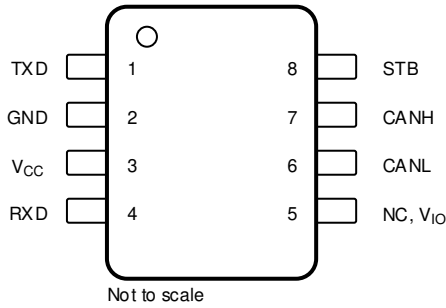
PINS		TYPE	DESCRIPTION
NAME	NO.		
TXD	1	Digital Input	CAN transmit data input, integrated pull-up
GND	2	GND	Ground connection
V _{CC}	3	Supply	5V supply voltage
RXD	4	Digital Output	CAN receive data output, tristate when powered off
V _{IO}	5	Supply	Logic supply voltage
NC		--	No Connect (not internally connected); Devices without V _{IO}
CANL	6	Bus IO	Low-level CAN bus input/output line
CANH	7	Bus IO	High-level CAN bus input/output line
STB	8	Digital Input	Standby mode control input, integrated pull-up
Thermal Pad (VSON only)		—	Electrically connected to GND, connect the thermal pad to the printed circuit board (PCB) ground plane for thermal relief

5 Specifications

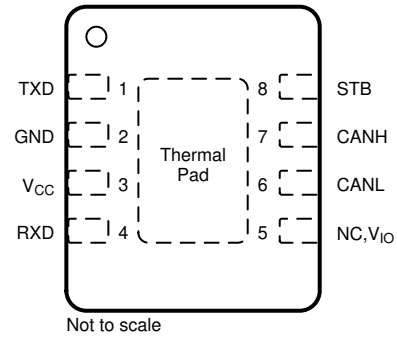
5.1 Absolute Maximum Ratings

(1) (2)

		MIN	MAX	UNIT
V _{CC}	Supply voltage	-0.3	6	V
V _{IO}	Supply voltage I/O level shifter (Devices with the "V" suffix)	-0.3	6	V
V _{BUS}	CAN bus I/O voltage range on CANH and CANL	-58	58	V
V _{DIFF}	Max differential voltage between CANH and CANL V _{DIFF} = (CANH - CANL)	-45	45	V
V _{Logic_Input}	Logic pin input voltage (TXD, STB)	-0.3	6	V
V _{RXD}	Logic output voltage range (RXD)	-0.3	6	V
I _{O(RXD)}	RXD output current	-8	8	mA
T _J	Junction temperature	-40	165	°C
T _{STG}	Storage temperature	-65	150	°C

- Operation outside the Absolute Maximum Ratings may cause permanent device damage. Absolute Maximum Ratings do not imply functional operation of the device at these or any other conditions beyond those listed under Recommended Operating Conditions. If used outside the Recommended Operating Conditions but within the Absolute Maximum Ratings, the device may not be fully functional, and this may affect device reliability, functionality, performance, and shorten the device lifetime.
- All voltage values, except differential I/O bus voltages, are with respect to ground terminal.

5.2 ESD Ratings

			VALUE	UNIT
V _{ESD}	Electrostatic discharge	Human-body model (HBM), per AEC Q100-002 ⁽¹⁾	±4000	V
			HBM classification level 3A for all pins	
			HBM classification level 3B for global pins CANH and CANL with respect to GND	±10000
		Charged-device model (CDM), per AEC Q100-011 CDM classification level C5 for all pins	±750	V

- AEC Q100-002 indicates that HBM stressing shall be in accordance with the ANSI/ESDA/JEDEC JS-001 specification.

5.3 ESD Ratings, IEC Transients

			VALUE	UNIT	
V _{ESD}	System level electrostatic discharge	CAN bus terminals (CANH, CANL) to GND	SAE J2962-2 per ISO 10605 Powered contact discharge	±8000	V
			SAE J2962-2 per ISO 10605 Powered air discharge	±15000	V
			IEC 62228-3 per ISO 10605	±8000	V
V _{Tran}	ISO 7637-2 Transient immunity ⁽¹⁾	CAN bus terminals (CANH, CANL) to GND	Pulse 1	-100	V
			Pulse 2a	75	V
			Pulse 3a	-150	V
			Pulse 3b	100	V
			Direct capacitor coupling, SAE J2962-2 per ISO 7637-3 ⁽²⁾	DCC slow transient pulse	±30

- Tested according to IEC 62228-3:2019 CAN Transceivers, Section 6.3; standard pulses parameters defined in ISO 7637-2 (2011)
- Tested according to SAE J2962-2

5.4 Recommended Operating Conditions

		MIN	NOM	MAX	UNIT
V _{CC}	Supply voltage	4.5	5	5.5	V
V _{IO}	Supply voltage for I/O level shifter (Devices with V _{IO})	1.7		5.5	V
I _{OH(RXD)}	RXD terminal high-level output current	-1.5			mA
I _{OL(RXD)}	RXD terminal low-level output current			1.5	mA
T _J	Junction temperature	-40		150	°C

5.5 Thermal Characteristics

THERMAL METRIC ⁽¹⁾		TCAN1472(V)-Q1			UNIT
		D (SOIC)	DDF (SOT)	DRB (VSON)	
R _{θJA}	Junction-to-ambient thermal resistance	113.6	129.2	52.3	°C/W
R _{θJC(top)}	Junction-to-case (top) thermal resistance	52.5	55.0	58.4	°C/W
R _{θJB}	Junction-to-board thermal resistance	61.1	48.1	24.7	°C/W
Ψ _{JT}	Junction-to-top characterization parameter	7.4	1.7	1.7	°C/W
Ψ _{JB}	Junction-to-board characterization parameter	60.2	47.9	24.6	°C/W
R _{θJC(bot)}	Junction-to-case (bottom) thermal resistance	-	-	8.9	°C/W

(1) For more information about traditional and new thermal metrics, see the [Semiconductor and IC Package Thermal Metrics](#) application report.

5.6 Supply Characteristics

parameters valid over recommended operating conditions with $-40^{\circ}\text{C} \leq T_J \leq 150^{\circ}\text{C}$ (Typical values are at V_{CC} = 5 V, V_{IO} = 3.3 V (for devices with V_{IO}), Device ambient maintained at 27°C) unless otherwise noted

PARAMETER		TEST CONDITIONS		MIN	TYP	MAX	UNIT	
I _{CC}	Supply current normal mode	Dominant	TXD = 0 V, STB = 0 V R _L = 60 Ω, C _L = open See 6-1		45	70	mA	
		Dominant	TXD = 0 V, STB = 0 V R _L = 50 Ω, C _L = open See 6-1		49	80	mA	
		Recessive	TXD = V _{IO} , STB = 0 V R _L = 50 Ω, C _L = open See 6-1		4.5	11	mA	
		Dominant with bus fault	TXD = 0 V, STB = 0 V CANH = CANL = ±25 V R _L = open, C _L = open See 6-1			130	mA	
	Supply current standby mode (devices with V _{IO})		TXD = STB = V _{IO} , R _L = 50 Ω, C _L = open, T _J ≤ 85 °C, See 6-1				1	μA
			TXD = STB = V _{IO} , R _L = 50 Ω, C _L = open, T _J ≤ 125 °C, See 6-1		0.2		2	
			TXD = STB = V _{IO} , R _L = 50 Ω, C _L = open, T _J ≤ 150 °C, See 6-1				5	
	Supply current standby mode (devices without V _{IO})		TXD = STB = V _{CC} , R _L = 50 Ω, C _L = open, T _J ≤ 85 °C, See 6-1				15	μA
			TXD = STB = V _{CC} , R _L = 50 Ω, C _L = open, T _J ≤ 125 °C, See 6-1				16	
			TXD = STB = V _{CC} , R _L = 50 Ω, C _L = open, T _J ≤ 150 °C, See 6-1				21	

5.6 Supply Characteristics (続き)

parameters valid over recommended operating conditions with $-40^{\circ}\text{C} \leq T_J \leq 150^{\circ}\text{C}$ (Typical values are at $V_{CC} = 5\text{ V}$, $V_{IO} = 3.3\text{ V}$ (for devices with V_{IO}), Device ambient maintained at 27°C) unless otherwise noted

PARAMETER		TEST CONDITIONS		MIN	TYP	MAX	UNIT
I_{IO} Devices with V_{IO}	I/O supply current normal mode	Dominant	TXD = 0 V, STB = 0 V $R_L = 60\ \Omega$, $C_L = \text{open}$ RXD floating		125	300	μA
		Recessive	TXD = V_{IO} , STB = 0 V $R_L = 60\ \Omega$, $C_L = \text{open}$ RXD floating		25	48	μA
	I/O supply current standby mode		TXD = V_{IO} , STB = V_{IO} $R_L = 60\ \Omega$, $C_L = \text{open}$ RXD floating, $T_J \leq 85^{\circ}\text{C}$			13.5	
			TXD = V_{IO} , STB = V_{IO} $R_L = 60\ \Omega$, $C_L = \text{open}$ RXD floating, $T_J \leq 125^{\circ}\text{C}$		8.5	15	μA
		TXD = V_{IO} , STB = V_{IO} $R_L = 60\ \Omega$, $C_L = \text{open}$ RXD floating, $T_J \leq 150^{\circ}\text{C}$			16		
$UV_{CC(R)}$	Undervoltage detection V_{CC} rising	Ramp up		4.2	4.4	V	
$UV_{CC(F)}$	Undervoltage detection on V_{CC} falling	Ramp down	3.5	4		V	
$UV_{IO(R)}$	Undervoltage detection V_{IO} rising (Devices with V_{IO})	Ramp up		1.6	1.65	V	
$UV_{IO(F)}$	Undervoltage detection on V_{IO} falling (Devices with V_{IO})	Ramp down	1.4	1.5		V	

5.7 Dissipation Ratings

PARAMETER		TEST CONDITIONS		MIN	TYP	MAX	UNIT
P_D	Average power dissipation Normal mode		$V_{CC} = 5\text{ V}$, $V_{IO} = 3.3\text{ V}$, $T_J = 27^{\circ}\text{C}$, $R_L = 60\ \Omega$, $C_{L_RXD} = 15\text{ pF}$ TXD input = 250 kHz 50% duty cycle square wave		60		mW
			$V_{CC} = 5.5\text{ V}$, $V_{IO} = 5.5\text{ V}$, $T_J = 150^{\circ}\text{C}$, $R_L = 50\ \Omega$, $C_{L_RXD} = 15\text{ pF}$ TXD input = 2.5 MHz 50% duty cycle square wave		120		mW
T_{TSD}	Thermal shutdown temperature				192		$^{\circ}\text{C}$
T_{TSD_HYS}	Thermal shutdown hysteresis				10		

5.8 Electrical Characteristics

parameters valid over recommended operating conditions with $-40^{\circ}\text{C} \leq T_J \leq 150^{\circ}\text{C}$ (Typical values are at $V_{CC} = 5\text{ V}$, $V_{IO} = 3.3\text{ V}$, Device ambient maintained at 27°C) unless otherwise noted

PARAMETER		TEST CONDITIONS		MIN	TYP	MAX	UNIT
Driver Electrical Characteristics							
$V_{CANH(D)}$	Dominant output voltage normal mode	CANH	$V_{CC} = 4.5\text{ V}$ to 5.5 V , TXD = 0 V, STB = 0 V	2.75	3.5	4.5	V
$V_{CANL(D)}$		CANL	$50\ \Omega \leq R_L \leq 65\ \Omega$, $C_L = \text{open}$, See 6-2 and 7-5	0.5	1.5	2.25	V
$V_{CANH(D)}$	Dominant output voltage normal mode	CANH	$V_{CC} = 4.75\text{ V}$ to 5.25 V , TXD = 0 V, STB = 0 V	3	3.5	4.26	V
$V_{CANL(D)}$		CANL	$45\ \Omega \leq R_L \leq 65\ \Omega$, $C_L = \text{open}$, See 6-2 and 7-5	0.75	1.5	2.01	V
$V_{CANH(R)}$, $V_{CANL(R)}$	Recessive output voltage normal mode	CANH and CANL	$V_{CC} = 4.5\text{ V}$ to 5.5 V , TXD = V_{IO} , STB = 0 V $R_L = \text{open}$ (no load), $C_L = \text{open}$, See 6-2 and 7-5	2	2.5	3	V

5.8 Electrical Characteristics (続き)

parameters valid over recommended operating conditions with $-40^{\circ}\text{C} \leq T_J \leq 150^{\circ}\text{C}$ (Typical values are at $V_{CC} = 5\text{ V}$, $V_{IO} = 3.3\text{ V}$, Device ambient maintained at 27°C) unless otherwise noted

PARAMETER			TEST CONDITIONS	MIN	TYP	MAX	UNIT
$V_{CANH(R)}$, $V_{CANL(R)}$	Recessive output voltage normal mode	CANH and CANL	$V_{CC} = 4.75\text{ V to } 5.25\text{ V}$, $\text{TXD} = V_{IO}$, $\text{STB} = 0\text{ V}$ $45\ \Omega \leq R_L \leq 65\ \Omega$, $C_L = 4.7\text{ nF}$ See 6-2 and 7-5	2.256		2.756	V
V_{SYM}	Driver symmetry $(V_{O(CANH)} + V_{O(CANL)}) / (V_{CANH(R)} + V_{CANL(R)})$		$\text{TXD} = 250\text{ kHz, } 1\text{ MHz, } 2.5\text{ MHz}$, $\text{STB} = 0\text{ V}$ $45\ \Omega \leq R_L \leq 65\ \Omega$, $C_{SPLIT} = 4.7\text{ nF}$, $C_L = \text{open}$, See 6-2 and 7-5	0.95		1.05	V/V
$V_{DIFF(D)}$	Differential output voltage normal mode Dominant	CANH - CANL	$\text{TXD} = 0\text{ V}$, $\text{STB} = 0\text{ V}$ $45\ \Omega \leq R_L \leq 65\ \Omega$, $C_L = \text{open}$, See 6-2 and 7-5	1.5		3	V
			$\text{TXD} = 0\text{ V}$, $\text{STB} = 0\text{ V}$ $45\ \Omega \leq R_L \leq 70\ \Omega$, $C_L = \text{open}$, See 6-2 and 7-5	1.5		3.3	V
			$\text{TXD} = 0\text{ V}$, $\text{STB} = 0\text{ V}$ $R_L = 2240\ \Omega$, $C_L = \text{open}$, See 6-2 and 7-5	1.5		5	V
$V_{DIFF(R)}$	Differential output voltage normal mode Recessive	CANH - CANL	$\text{TXD} = V_{IO}$, $\text{STB} = 0\text{ V}$ $45\ \Omega \leq R_L \leq 65\ \Omega$, $C_{SPLIT} = 4.7\text{ nF}$, $C_L = \text{open}$, See 6-2 and 7-5	-50		50	mV
			$\text{TXD} = V_{IO}$, $\text{STB} = 0\text{ V}$ $R_L = \text{open}$, $C_L = \text{open}$, See 6-2 and 7-5	-50		50	mV
$V_{CANH(INACT)}$	Bus output voltage standby mode	CANH	$\text{TXD} = \text{STB} = V_{IO}$ $R_L = \text{open}$, $C_L = \text{open}$, See 6-2 and 7-5	-0.1		0.1	V
$V_{CANL(INACT)}$		CANL		-0.1		0.1	V
$V_{DIFF(INACT)}$		CANH - CANL		-0.2		0.2	V
$R_{DIFF(DOM)}$	Differential input resistance in dominant phase		$\text{TXD} = 0\text{ V}$, $\text{STB} = 0\text{ V}$, See 7-2		40		Ω
$R_{SE_SIC_ACT_REC}$	Single ended resistance CANH/CANL in active recessive phase		$2\text{ V} \leq V_{CANH/L} \leq V_{CC} - 2\text{ V}$	37.5	50	66.5	Ω
$R_{DIFF_SIC_ACT_REC}$	Differential input resistance in active recessive drive phase		$2\text{ V} \leq V_{CANH/L} \leq V_{CC} - 2\text{ V}$	75	100	133	Ω
$I_{CANH(OS)}$	Short-circuit bus output current, TXD is dominant or recessive or toggling, normal mode		$V_{(CANH)} = -15\text{ V to } 40\text{ V}$, $\text{CANL} = \text{open}$, $\text{TXD} = 0\text{ V}$ or V_{IO} or $250\text{ kHz, } 2.5\text{ MHz}$ square wave, See 6-7 and 7-5	-115		115	mA
$I_{CANL(OS)}$			$V_{(CANL)} = -15\text{ V to } 40\text{ V}$, $\text{CANH} = \text{open}$, $\text{TXD} = 0\text{ V}$ or V_{IO} or $250\text{ kHz, } 2.5\text{ MHz}$ square wave, See 6-7 and 7-5	-115		115	mA
Receiver Electrical Characteristics							
V_{IT}	Input threshold voltage normal mode		$-12\text{ V} \leq V_{CM} \leq 12\text{ V}$, $\text{STB} = 0\text{ V}$, See 6-3 and 7-6	500		900	mV
$V_{IT(STB)}$	Input threshold standby mode		$-12\text{ V} \leq V_{CM} \leq 12\text{ V}$, $\text{STB} = V_{IO}$, See 6-3 and 7-6	400		1150	mV
$V_{DIFF_RX(D)}$	Normal mode dominant state differential input voltage range		$-12\text{ V} \leq V_{CM} \leq 12\text{ V}$, $\text{STB} = 0\text{ V}$, See 6-3 and 7-6	0.9		9	V
$V_{DIFF_RX(R)}$	Normal mode recessive state differential input voltage range		$-12\text{ V} \leq V_{CM} \leq 12\text{ V}$, $\text{STB} = 0\text{ V}$, See 6-3 and 7-6	-4		0.5	V
$V_{DIFF_RX(D_INACT)}$	Standby mode dominant state differential input voltage range		$\text{STB} = V_{IO}$, $-12\text{ V} \leq V_{CM} \leq 12\text{ V}$, See 6-3 and 7-6	1.15		9	V
$V_{DIFF_RX(R_INACT)}$	Standby mode recessive state differential input voltage range		$\text{STB} = V_{IO}$, $-12\text{ V} \leq V_{CM} \leq 12\text{ V}$, See 6-3 and 7-6	-4		0.4	V
V_{HYS}	Hysteresis voltage for input threshold normal mode		$-12\text{ V} \leq V_{CM} \leq 12\text{ V}$, $\text{STB} = 0\text{ V}$, See 6-3 and 7-6		100		mV
V_{CM}	Common mode range normal and standby modes		See 6-3 and 7-6	-12		12	V

5.8 Electrical Characteristics (続き)

parameters valid over recommended operating conditions with $-40^{\circ}\text{C} \leq T_J \leq 150^{\circ}\text{C}$ (Typical values are at $V_{CC} = 5\text{ V}$, $V_{IO} = 3.3\text{ V}$, Device ambient maintained at 27°C) unless otherwise noted

PARAMETER		TEST CONDITIONS	MIN	TYP	MAX	UNIT
$I_{LKG(OFF)}$	Unpowered bus input leakage current	CANH = CANL = 5 V, $V_{CC} = V_{IO} = \text{GND}$			5	μA
C_I	Input capacitance to ground (CANH or CANL)				30	pF
C_{ID}	Differential input capacitance across bus terminals	$\text{TXD} = V_{IO}$			15	pF
$R_{DIFF_PAS_RE_C}$	Differential input resistance in passive recessive phase		40		90	k Ω
$R_{SE_PAS_REC}$	Single ended input resistance in passive recessive phase (CANH or CANL)	$\text{TXD} = V_{IO}$, $\text{STB} = 0\text{ V}$, $-12\text{ V} \leq V_{CM} \leq 12\text{ V}$, $\Delta V/\Delta I$	20		45	k Ω
m_R	Input resistance matching $[1 - (R_{IN(CANH)} / R_{IN(CANL)})] \times 100\%$	$V_{(CAN_H)} = V_{(CAN_L)} = 5\text{ V}$	-1		1	%
TXD Terminal (CAN Transmit Data Input)						
V_{IH}	High-level input voltage	Devices without V_{IO}	0.7 V_{CC}			V
V_{IH}	High-level input voltage	Devices with V_{IO}	0.7 V_{IO}			V
V_{IL}	Low-level input voltage	Devices without V_{IO}			0.3 V_{CC}	V
V_{IL}	Low-level input voltage	Devices with V_{IO}			0.3 V_{IO}	V
I_{IH}	High-level input leakage current	$\text{TXD} = V_{CC} = V_{IO} = 5.5\text{ V}$	-2.5	0	1	μA
I_{IL}	Low-level input leakage current	$\text{TXD} = 0\text{ V}$, $V_{CC} = V_{IO} = 5.5\text{ V}$	-200	-100	-20	μA
$I_{LKG_TXD(OFF)}$	Unpowered leakage current	$\text{TXD} = 5.5\text{ V}$, $V_{CC} = V_{IO} = 0\text{ V}$	-1	0	1	μA
C_{I_TXD}	Input capacitance	$V_{IN} = 0.4 \times \sin(2 \times \pi \times 2 \times 10^6 \times t) + 2.5\text{ V}$		6		pF
RXD Terminal (CAN Receive Data Output)						
V_{OH}	High-level output voltage	Devices without V_{IO} $I_O = -1.5\text{ mA}$, See 6-3	0.8 V_{CC}			V
V_{OH}	High-level output voltage	$I_O = -1.5\text{ mA}$, Devices with V_{IO} See 6-3	0.8 V_{IO}			V
V_{OL}	Low-level output voltage	Devices without V_{IO} $I_O = 1.5\text{ mA}$, See 6-3			0.2 V_{CC}	V
V_{OL}	Low-level output voltage	Devices with V_{IO} $I_O = 1.5\text{ mA}$, Devices with V_{IO} See 6-3			0.2 V_{IO}	V
$I_{LKG_RXD(OFF)}$	Unpowered leakage current	$\text{RXD} = 5.5\text{ V}$, $V_{CC} = V_{IO} = 0\text{ V}$	-1	0	1	μA
STB Terminal (Standby Mode Input)						
V_{IH}	High-level input voltage	Devices without V_{IO}	0.7 V_{CC}			V
V_{IH}	High-level input voltage	Devices with V_{IO}	0.7 V_{IO}			V
V_{IL}	Low-level input voltage	Devices without V_{IO}			0.3 V_{CC}	V
V_{IL}	Low-level input voltage	Devices with V_{IO}			0.3 V_{IO}	V
I_{IH}	High-level input leakage current	$V_{CC} = V_{IO} = \text{STB} = 5.5\text{ V}$	-2		2	μA
I_{IL}	Low-level input leakage current	$V_{CC} = V_{IO} = 5.5\text{ V}$, $\text{STB} = 0\text{ V}$	-20		-2	μA
$I_{LKG_STB(OFF)}$	Unpowered leakage current	$\text{STB} = 5.5\text{ V}$, $V_{CC} = V_{IO} = 0\text{ V}$	-1	0	1	μA

5.9 Switching Characteristics

parameters valid over recommended operating conditions with $-40^{\circ}\text{C} \leq T_J \leq 150^{\circ}\text{C}$ (Typical values are at $V_{CC} = 5\text{ V}$, $V_{IO} = 3.3\text{ V}$, Device ambient maintained at 27°C) unless otherwise noted

PARAMETER	TEST CONDITIONS	MIN	TYP	MAX	UNIT
Device Switching Characteristics					

5.9 Switching Characteristics (続き)

parameters valid over recommended operating conditions with $-40^{\circ}\text{C} \leq T_J \leq 150^{\circ}\text{C}$ (Typical values are at $V_{CC} = 5\text{ V}$, $V_{IO} = 3.3\text{ V}$, Device ambient maintained at 27°C) unless otherwise noted

PARAMETER		TEST CONDITIONS	MIN	TYP	MAX	UNIT
$t_{\text{PROP(LOOP1)}}$	Total loop delay, driver input (TXD) to receiver output (RXD), recessive to dominant	See 6-4 , normal mode, $V_{IO} = 4.5\text{ V}$ to 5.5 V , $45\ \Omega \leq R_L \leq 65\ \Omega$, $C_L = 100\text{ pF}$ ($\leq \pm 1\%$), $C_{L(\text{RXD})} = 15\text{ pF}$ ($\leq \pm 1\%$)		95	145	ns
		See 6-4 , normal mode, $V_{IO} = 3\text{ V}$ to 3.6 V , $45\ \Omega \leq R_L \leq 65\ \Omega$, $C_L = 100\text{ pF}$ ($\leq \pm 1\%$), $C_{L(\text{RXD})} = 15\text{ pF}$ ($\leq \pm 1\%$)		100	155	ns
		See 6-4 , normal mode, $V_{IO} = 2.25\text{ V}$ to 2.75 V , $45\ \Omega \leq R_L \leq 65\ \Omega$, $C_L = 100\text{ pF}$ ($\leq \pm 1\%$), $C_{L(\text{RXD})} = 15\text{ pF}$ ($\leq \pm 1\%$)		105	170	ns
		See 6-4 , normal mode, $V_{IO} = 1.71\text{ V}$ to 1.89 V , $45\ \Omega \leq R_L \leq 65\ \Omega$, $C_L = 100\text{ pF}$ ($\leq \pm 1\%$), $C_{L(\text{RXD})} = 15\text{ pF}$ ($\leq \pm 1\%$)		120	190	ns
$t_{\text{PROP(LOOP2)}}$	Total loop delay, driver input (TXD) to receiver output (RXD), dominant to recessive	See 6-4 , normal mode, $V_{IO} = 4.5\text{ V}$ to 5.5 V , $45\ \Omega \leq R_L \leq 65\ \Omega$, $C_L = 100\text{ pF}$ ($\leq \pm 1\%$), $C_{L(\text{RXD})} = 15\text{ pF}$ ($\leq \pm 1\%$)		110	150	ns
		See 6-4 , normal mode, $V_{IO} = 3\text{ V}$ to 3.6 V , $45\ \Omega \leq R_L \leq 65\ \Omega$, $C_L = 100\text{ pF}$ ($\leq \pm 1\%$), $C_{L(\text{RXD})} = 15\text{ pF}$ ($\leq \pm 1\%$)		115	160	ns
		See 6-4 , normal mode, $V_{IO} = 2.25\text{ V}$ to 2.75 V , $45\ \Omega \leq R_L \leq 65\ \Omega$, $C_L = 100\text{ pF}$ ($\leq \pm 1\%$), $C_{L(\text{RXD})} = 15\text{ pF}$ ($\leq \pm 1\%$)		120	175	ns
		See 6-4 , normal mode, $V_{IO} = 1.71\text{ V}$ to 1.89 V , $45\ \Omega \leq R_L \leq 65\ \Omega$, $C_L = 100\text{ pF}$ ($\leq \pm 1\%$), $C_{L(\text{RXD})} = 15\text{ pF}$ ($\leq \pm 1\%$)		135	190	ns
t_{MODE}	Mode change time, from normal to standby or from standby to normal	See 6-5			30	μs
$t_{\text{WK_FILTER}}$	Filter time for a valid wake-up pattern	See 7-7	0.5		0.95	μs
$t_{\text{WK_TIMEOUT}}$	Bus wake-up timeout value	See 7-7	0.8		6	ms
Tstartup	Time duration after V_{CC} or V_{IO} has cleared rising undervoltage threshold, and device can resume normal operation				1.5	ms
$T_{\text{filter(STB)}}$	Filter on STB pin to filter out any glitches		0.5	1	2	μs
Driver Switching Characteristics						
$t_{\text{prop(TxD-busrec)}}$	Propagation delay time, low-to-high TXD edge to driver recessive (dominant to recessive)	See 6-2 , STB = 0 V , $45\ \Omega \leq R_L \leq 65\ \Omega$, $C_L = 100\text{ pF}$ ($\leq \pm 1\%$), $V_{IO} = 4.5\text{ V}$ to 5.5 V		50	70	ns
		See 6-2 STB = 0 V , $45\ \Omega \leq R_L \leq 65\ \Omega$, $C_L = 100\text{ pF}$ ($\leq \pm 1\%$), $V_{IO} = 3\text{ V}$ to 3.6 V		50	70	ns
		See 6-2 STB = 0 V , $45\ \Omega \leq R_L \leq 65\ \Omega$, $C_L = 100\text{ pF}$ ($\leq \pm 1\%$), $V_{IO} = 2.25\text{ V}$ to 2.75 V		55	75	ns
		See 6-2 STB = 0 V , $45\ \Omega \leq R_L \leq 65\ \Omega$, $C_L = 100\text{ pF}$ ($\leq \pm 1\%$), $V_{IO} = 1.71\text{ V}$ to 1.89 V		55	80	ns
$t_{\text{prop(TxD-busdom)}}$	Propagation delay time, high-to-low TXD edge to driver dominant (recessive to dominant)	See 6-2 , STB = 0 V , $45\ \Omega \leq R_L \leq 65\ \Omega$, $C_L = 100\text{ pF}$ ($\leq \pm 1\%$), $V_{IO} = 4.5\text{ V}$ to 5.5 V		45	75	ns
		See 6-2 STB = 0 V , $45\ \Omega \leq R_L \leq 65\ \Omega$, $C_L = 100\text{ pF}$ ($\leq \pm 1\%$), $V_{IO} = 3\text{ V}$ to 3.6 V		50	75	ns
		See 6-2 STB = 0 V , $45\ \Omega \leq R_L \leq 65\ \Omega$, $C_L = 100\text{ pF}$ ($\leq \pm 1\%$), $V_{IO} = 2.25\text{ V}$ to 2.75 V		50	80	ns
		See 6-2 STB = 0 V , $45\ \Omega \leq R_L \leq 65\ \Omega$, $C_L = 100\text{ pF}$ ($\leq \pm 1\%$), $V_{IO} = 1.71\text{ V}$ to 1.89 V		55	80	ns
$t_{\text{sk(p)}}$	Pulse skew ($(t_{\text{prop(TxD-busrec)}} - t_{\text{prop(TxD-busdom)}})$)	STB = 0 V , $45\ \Omega \leq R_L \leq 65\ \Omega$, $C_L = 100\text{ pF}$ ($\leq \pm 1\%$), See 6-2		3.5	10	ns

5.9 Switching Characteristics (続き)

parameters valid over recommended operating conditions with $-40^{\circ}\text{C} \leq T_J \leq 150^{\circ}\text{C}$ (Typical values are at $V_{CC} = 5\text{ V}$, $V_{IO} = 3.3\text{ V}$, Device ambient maintained at 27°C) unless otherwise noted

PARAMETER		TEST CONDITIONS	MIN	TYP	MAX	UNIT
$t_{\text{BUS_R}}$	Differential output signal rise time	See 6-2 , STB = 0 V, $45\ \Omega \leq R_L \leq 65\ \Omega$, $C_L = 100\ \text{pF}$ ($\leq \pm 1\%$)		20	30	ns
$t_{\text{BUS_F}}$	Differential output signal fall time	See 6-2 , STB = 0 V, $45\ \Omega \leq R_L \leq 65\ \Omega$, $C_L = 100\ \text{pF}$ ($\leq \pm 1\%$)		30	40	ns
$t_{\text{TXD_DTO}}$	Dominant timeout	See 6-6 , $45\ \Omega \leq R_L \leq 65\ \Omega$, $C_L = 100\ \text{pF}$ ($\leq \pm 1\%$), STB = 0 V	1.2		4.0	ms
Receiver Switching Characteristics						
$t_{\text{prop(busrec-RXD)}}$	Propagation delay time, bus recessive input to RXD high output (dominant to recessive)	See 6-3 , STB = 0 V, $45\ \Omega \leq R_L \leq 65\ \Omega$, $C_L = 100\ \text{pF}$ ($\leq \pm 1\%$), $C_{L(\text{RXD})} = 15\ \text{pF}$ ($\leq \pm 1\%$), $V_{IO} = 4.5\text{ V}$ to 5.5 V		60	85	ns
		See 6-3 STB = 0 V, $45\ \Omega \leq R_L \leq 65\ \Omega$, $C_L = 100\ \text{pF}$ ($\leq \pm 1\%$), $C_{L(\text{RXD})} = 15\ \text{pF}$ ($\leq \pm 1\%$), $V_{IO} = 3\text{ V}$ to 3.6 V		65	95	ns
		See 6-3 STB = 0 V, $45\ \Omega \leq R_L \leq 65\ \Omega$, $C_L = 100\ \text{pF}$ ($\leq \pm 1\%$), $C_{L(\text{RXD})} = 15\ \text{pF}$ ($\leq \pm 1\%$), $V_{IO} = 2.25\text{ V}$ to 2.75 V		70	105	ns
		See 6-3 STB = 0 V, $45\ \Omega \leq R_L \leq 65\ \Omega$, $C_L = 100\ \text{pF}$ ($\leq \pm 1\%$), $C_{L(\text{RXD})} = 15\ \text{pF}$ ($\leq \pm 1\%$), $V_{IO} = 1.71\text{ V}$ to 1.89 V		80	110	ns
$t_{\text{prop(busdom-RXD)}}$	Propagation delay time, bus dominant input to RXD low output (recessive to dominant)	See 6-3 , STB = 0 V, $45\ \Omega \leq R_L \leq 65\ \Omega$, $C_L = 100\ \text{pF}$ ($\leq \pm 1\%$), $C_{L(\text{RXD})} = 15\ \text{pF}$ ($\leq \pm 1\%$), $V_{IO} = 4.5\text{ V}$ to 5.5 V		50	75	ns
		See 6-3 STB = 0 V, $45\ \Omega \leq R_L \leq 65\ \Omega$, $C_L = 100\ \text{pF}$ ($\leq \pm 1\%$), $C_{L(\text{RXD})} = 15\ \text{pF}$ ($\leq \pm 1\%$), $V_{IO} = 3\text{ V}$ to 3.6 V		50	80	ns
		See 6-3 STB = 0 V, $45\ \Omega \leq R_L \leq 65\ \Omega$, $C_L = 100\ \text{pF}$ ($\leq \pm 1\%$), $C_{L(\text{RXD})} = 15\ \text{pF}$ ($\leq \pm 1\%$), $V_{IO} = 2.25\text{ V}$ to 2.75 V		55	90	ns
		See 6-3 STB = 0 V, $45\ \Omega \leq R_L \leq 65\ \Omega$, $C_L = 100\ \text{pF}$ ($\leq \pm 1\%$), $C_{L(\text{RXD})} = 15\ \text{pF}$ ($\leq \pm 1\%$), $V_{IO} = 1.71\text{ V}$ to 1.89 V		65	110	ns
$t_{\text{RXD_R}}$	RXD output signal rise time	See 6-3 , STB = 0 V,		8	20	ns
$t_{\text{RXD_F}}$	RXD output signal fall time	$C_{L(\text{RXD})} = 15\ \text{pF}$ ($\leq \pm 1\%$)		7	25	ns
Signal Improvement Timing Characteristics						
$t_{\text{PAS_REC_START}}$	Start time of passive recessive phase	Time duration from TXD rising 50% edge (<5ns slope) to start of passive recessive phase			530	ns
$t_{\text{ACT_REC_START}}$	Start time of active signal improvement phase	Time duration from TXD rising 50% edge (<5ns slope) to start of passive recessive phase			120	ns
$t_{\text{ACT_REC_END}}$	End time of active signal improvement phase		355		ns	
$t_{\Delta \text{Bit(Bus)}}$	Transmitted bit width variation	TXD <= 5Mbps square wave, $t_{\Delta \text{Bit(Bus)}} = t_{\text{Bit(Bus)}} - t_{\text{Bit(TXD)}}$ STB = 0 V, $45\ \Omega \leq R_L \leq 65\ \Omega$, $C_L = 100\ \text{pF}$ ($\leq \pm 1\%$), $C_{L(\text{RXD})} = 15\ \text{pF}$ ($\leq \pm 1\%$), See 6-4	-10		10	ns
$t_{\Delta \text{BIT(RXD)}}$	Received bit width variation	TXD <= 5Mbps square wave, $t_{\Delta \text{BIT(RXD)}} = t_{\text{Bit(RXD)}} - t_{\text{Bit(TXD)}}$ STB = 0 V, $45\ \Omega \leq R_L \leq 65\ \Omega$, $C_L = 100\ \text{pF}$ ($\leq \pm 1\%$), $C_{L(\text{RXD})} = 15\ \text{pF}$ ($\leq \pm 1\%$), $C_{L(\text{RXD})} = 15\ \text{pF}$, See 6-4	-30		20	ns
$t_{\Delta \text{REC}}$	Receiver timing symmetry	TXD <= 5Mbps square wave, $t_{\Delta \text{REC}} = t_{\text{Bit(RXD)}} - t_{\text{Bit(Bus)}}$ STB = 0 V, $45\ \Omega \leq R_L \leq 65\ \Omega$, $C_L = 100\ \text{pF}$ ($\leq \pm 1\%$), $C_{L(\text{RXD})} = 15\ \text{pF}$ ($\leq \pm 1\%$), See 6-4	-20		15	ns

6 Parameter Measurement Information



図 6-1. I_{CC} Test Circuit



図 6-2. Driver Test Circuit and Measurement

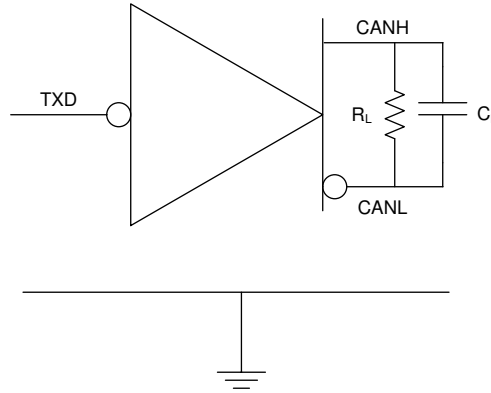

図 6-3. Receiver Test Circuit and Measurement

ADVANCE INFORMATION

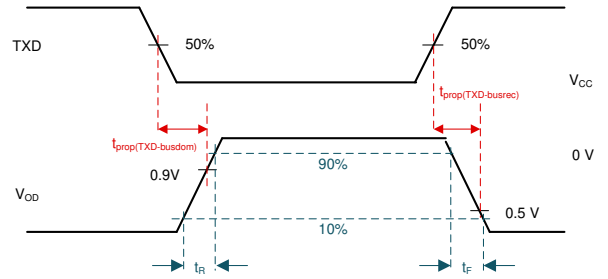
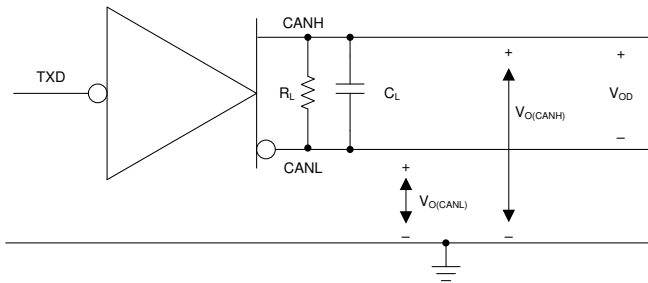

图 6-4. Transmitter and Receiver Timing Behavior Test Circuit and Measurement

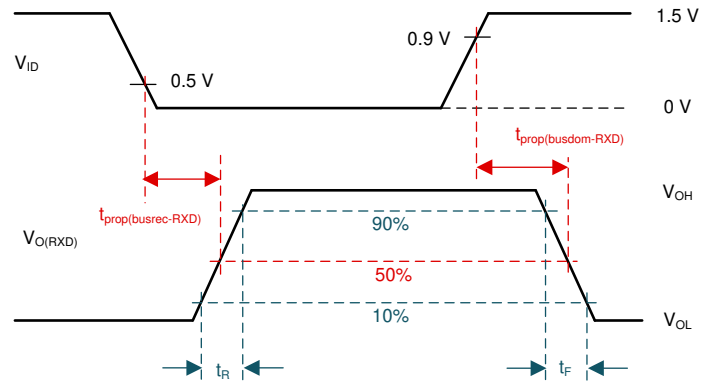
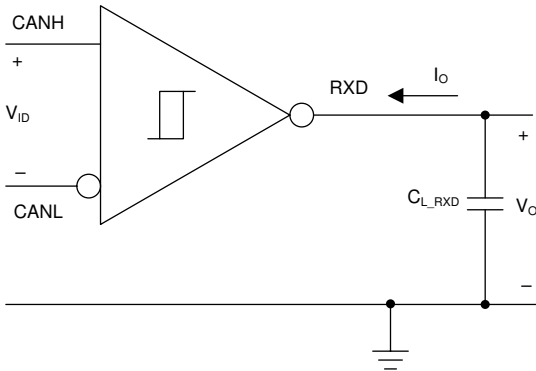

图 6-5. t_{MODE} Test Circuit and Measurement

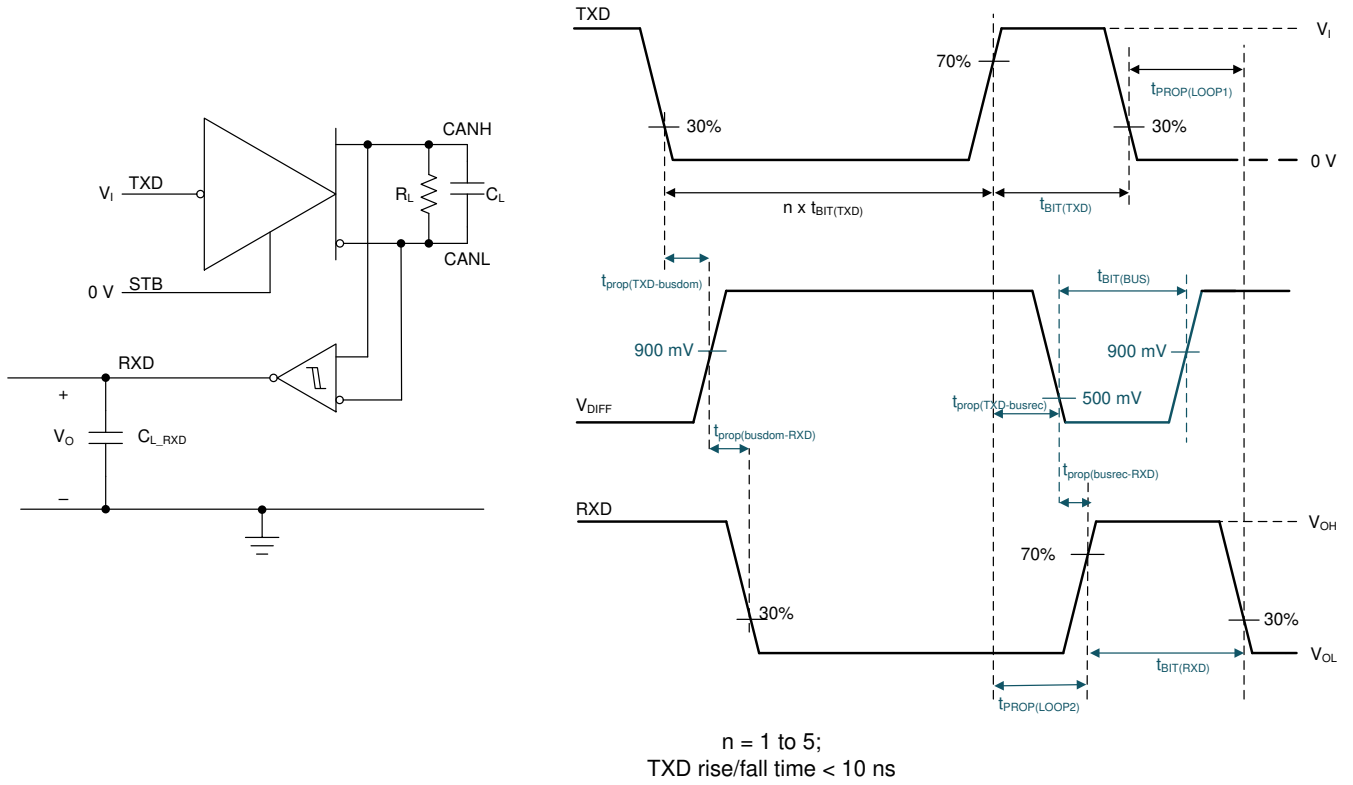

图 6-6. TXD Dominant Timeout Test Circuit and Measurement

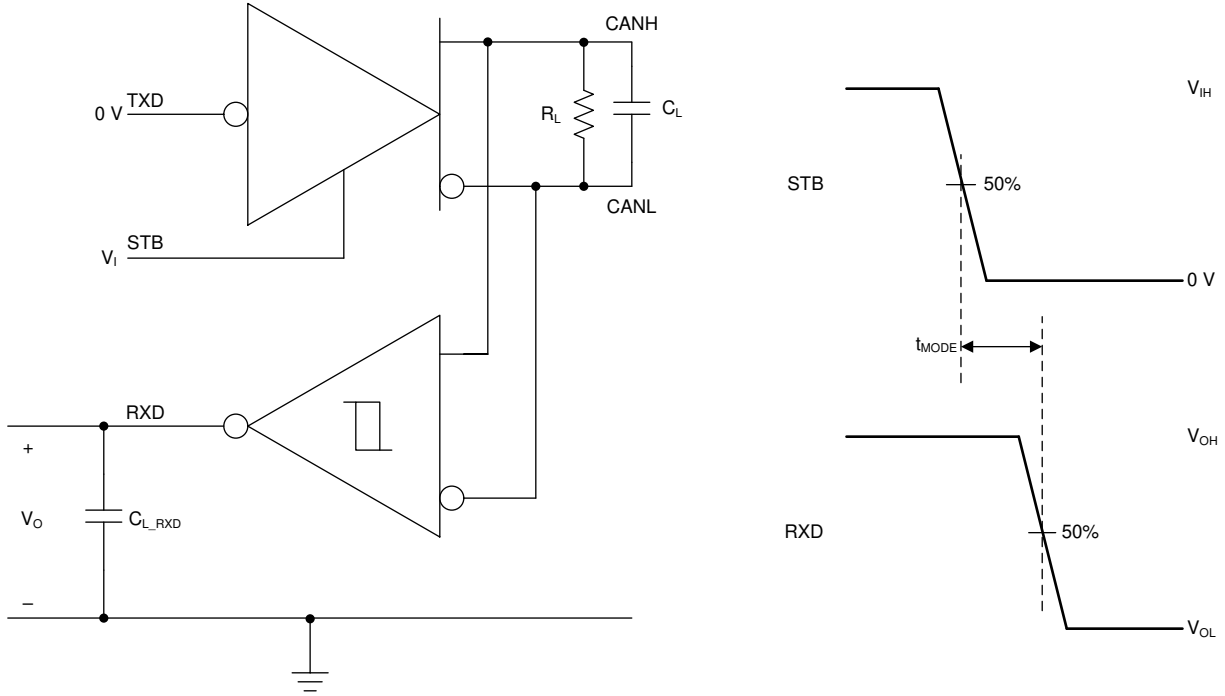

图 6-7. Driver Short-Circuit Current Test and Measurement

7 Detailed Description

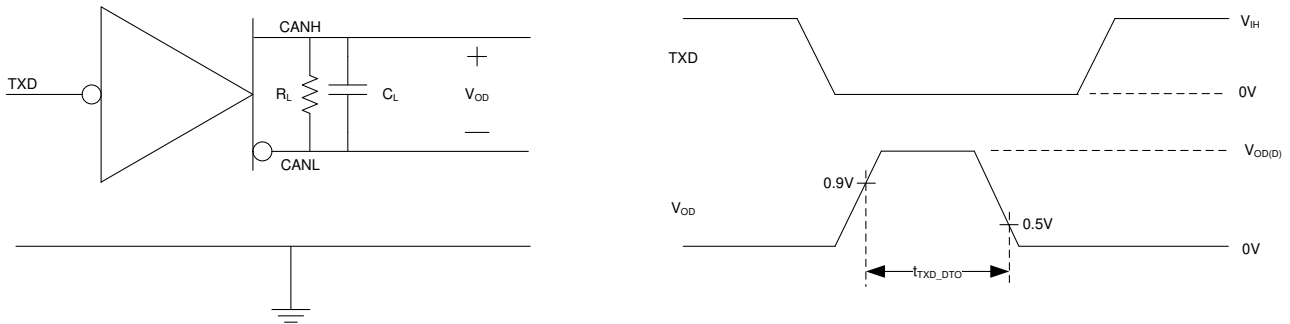
7.1 Overview

The TCAN1472V(D)-Q1 devices meet or exceed the specifications of the Annex A Signal Improvement capability (SIC) specification of ISO 11898-2:2023 Controller Area Network physical layer standard. The devices are data rate agnostic making them backward compatible for supporting classical CAN applications while also supporting CAN FD networks up to 8Mbps. These devices have standby mode support which puts the transceiver in ultra-low current consumption mode. Upon receiving a valid wake-up pattern (WUP) on the CAN bus, the device signals to the microcontroller through the RXD pin. The MCU can then put the device into normal mode using the STB pin.

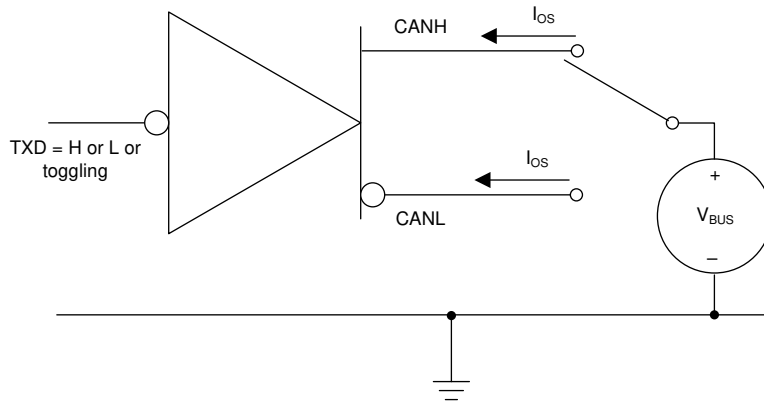
The TCAN1472V-Q1 has two separate supply rails, V_{CC} bus-side supply and V_{IO} logic supply for logic-level translation for interfacing directly to 1.8V, 2.5V, 3.3V, or 5V controllers.

7.1.1 Signal Improvement

Signal improvement is an additional capability added to CAN FD transceiver that enhances the maximum data rate achievable in complex star topologies by minimizing signal ringing. Signal ringing is the result of reflections caused by impedance mismatch at various points in a CAN network due to the nodes that act as stubs.

An example of a complex network is shown in [Figure 7-1](#).

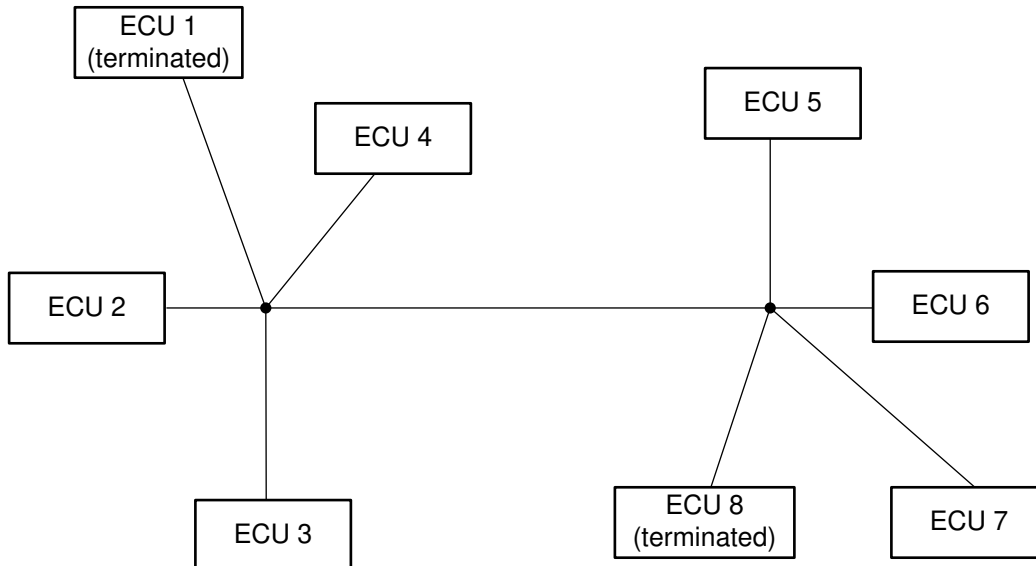

Figure 7-1. CAN Network: Star topology

Recessive-to-dominant signal edge is usually clean and driven by the transmitter. Transmitter output impedance of CAN transceiver is approximately 50Ω and matches to the network characteristic impedance. For a regular CAN FD transceiver, dominant-to-recessive edge is when the driver output impedance goes to approximately $60k\Omega$ and signal reflected back experiences impedance mismatch which causes ringing. TCAN1472-Q1 resolves this issue by TX-based Signal improvement capability (SIC). The device continues to drive the bus recessive until $t_{SIC_TX_base}$ so that reflections die down and recessive bit is clean at sampling point. In the active recessive phase, transmitter output impedance is low (approximately 100Ω). After this phase is over and device goes to passive recessive phase, driver output impedance goes to high-Z. This phenomenon is explained with [Figure 7-2](#).

For more information on the TI signal improvement technology, and how it compares with similar devices in market, please refer to the white paper [How Signal Improvement Capability Unlocks the Real Potential of CAN-FD Transceivers](#).



図 7-2. TX based SIC

7.2 Functional Block Diagram

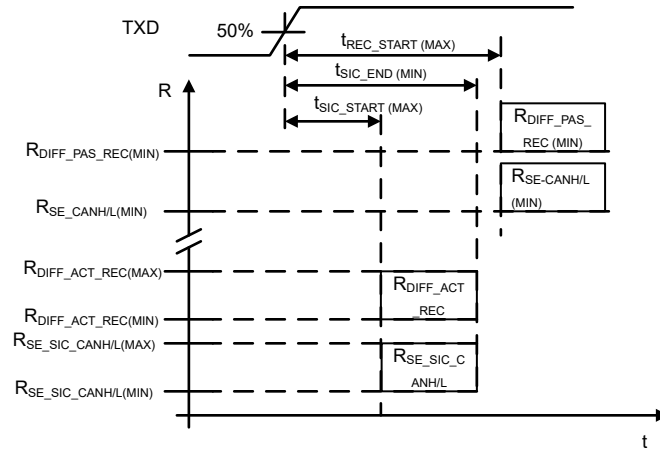

図 7-3. Block Diagram

ADVANCE INFORMATION

7.3 Feature Description

7.3.1 Pin Description

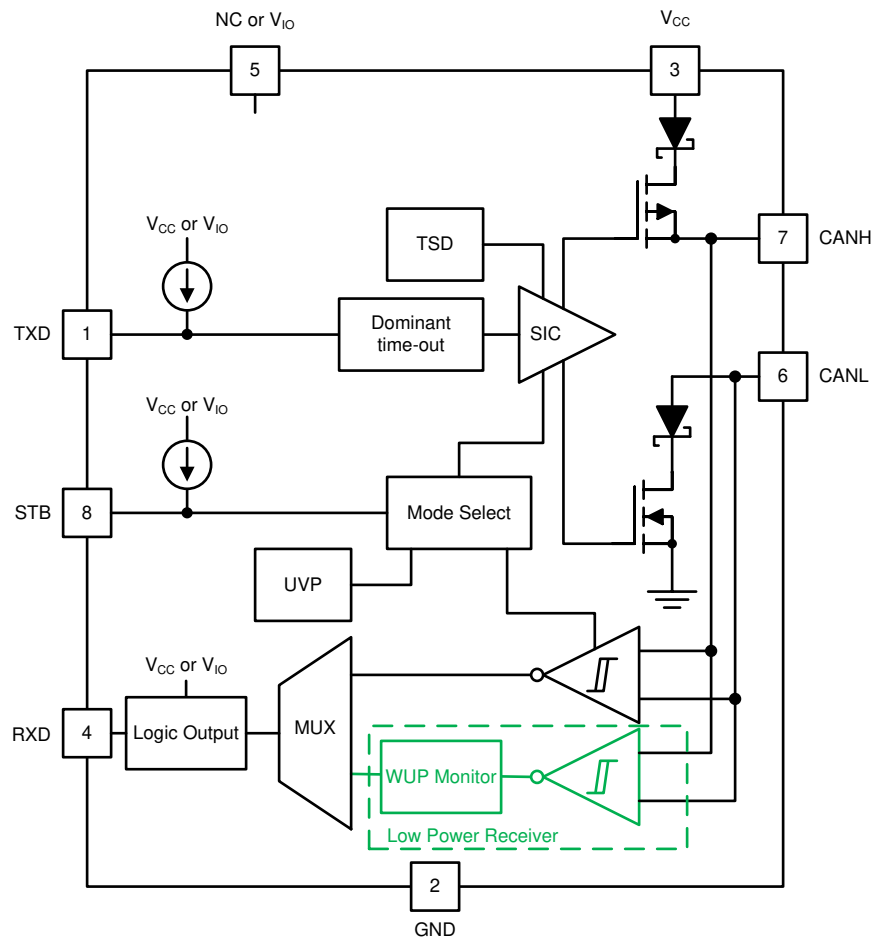
7.3.1.1 TXD

The TXD input is a logic-level signal from a CAN controller to the transceiver. The input is referenced to V_{CC} for TCAN1472-Q1, or to V_{IO} for TCAN1472V-Q1.

7.3.1.2 GND

GND is the ground pin of the transceiver. The pin must be connected to the PCB ground.

7.3.1.3 V_{CC}

V_{CC} provides the 5V power supply to the CAN transceiver.

7.3.1.4 RXD

The RXD output is a logic-level signal from the CAN transceiver to the CAN controller. The output is referenced to V_{CC} for TCAN1472-Q1 and V_{IO} for TCAN1472V-Q1. For TCAN1472V-Q1, RXD is only driven once V_{IO} is present.

When a wake event takes place, RXD is driven low.

7.3.1.5 V_{IO} (TCAN1472V-Q1 only)

The V_{IO} pin provides the digital I/O voltage to match the CAN controller voltage; thus, avoiding the requirement for a level shifter. The pin supports a wide range of controller interface voltage levels from 1.7V to 5.5V.

7.3.1.6 CANH and CANL

These are the CAN high and CAN low differential bus pins. The pins are connected to the CAN transceiver and the low-voltage WUP CAN receiver.

7.3.1.7 STB (Standby)

The STB pin is an input pin used for mode control of the transceiver. The STB pin can be supplied from either the system processor or from a static system voltage source. If normal mode is the only intended mode of operation, then the STB pin can be tied directly to GND.

7.3.2 CAN Bus States

The CAN bus has two logical states during operation: recessive and dominant. See [Figure 7-4](#) and [Figure 7-5](#).

A dominant bus state occurs when the bus is driven differentially and corresponds to a logic low on the TXD and RXD pins. A recessive bus state occurs when the bus is biased to $V_{CC}/2$ via the high-resistance internal input resistors (R_{IN}) of the receiver and corresponds to a logic high on the TXD and RXD pins.

A dominant state overwrites the recessive state during arbitration. Multiple CAN nodes may be transmitting a dominant bit at the same time during arbitration, and in this case the differential voltage of the bus is greater than the differential voltage of a single driver.

The TCAN1472-Q1 transceiver implements a low-power standby (STB) mode which enables a third bus state where the bus pins are weakly biased to ground via the high resistance internal resistors of the receiver. See [Figure 7-4](#) and [Figure 7-5](#).

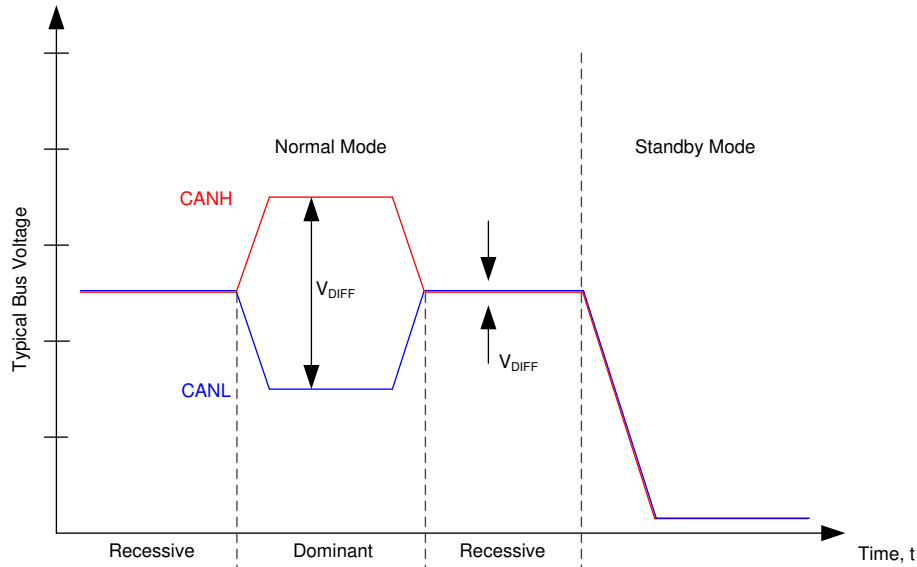

7-4. Bus States

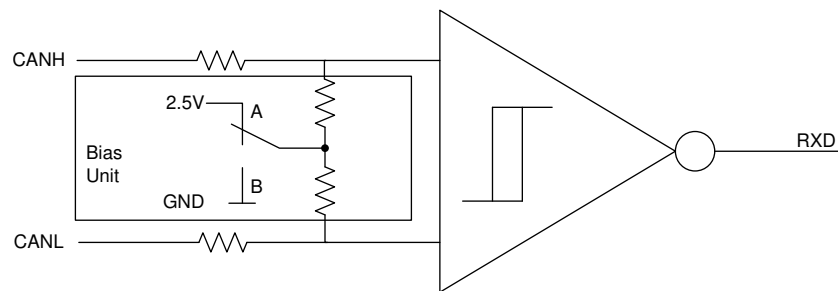

- A. Normal Mode
- B. Standby Mode

7-5. Simplified Recessive Common Mode Bias Unit and Receiver

7.3.3 TXD Dominant Timeout (DTO)

During normal mode, the only mode where the CAN driver is active, the TXD DTO circuit prevents the local node from blocking network communication in the event of a hardware or software failure where TXD is held dominant longer than the timeout period t_{TXD_DTO} . The TXD DTO circuit is triggered by a falling edge on TXD. If no rising edge is seen before the timeout period of the circuit, t_{TXD_DTO} , the CAN driver is disabled. Freeing the bus for communication between other nodes on the network. The CAN driver is reactivated when a recessive signal is seen on the TXD pin; thus, clearing the dominant time out. The receiver remains active and biased to $V_{CC}/2$ and the RXD output reflects the activity on the CAN bus during the TXD DTO fault.

The minimum dominant TXD time allowed by the TXD DTO circuit limits the minimum possible transmitted data rate of the device. The CAN protocol allows a maximum of eleven successive dominant bits (on TXD) for the worst case, where five successive dominant bits are followed immediately by an error frame. The minimum transmitted data rate may be calculated using 式 1.

$$\text{Minimum Data Rate} = 11 \text{ bits} / t_{TXD_DTO} = 11 \text{ bits} / 1.2\text{ms} = 9.2\text{kbps} \quad (1)$$

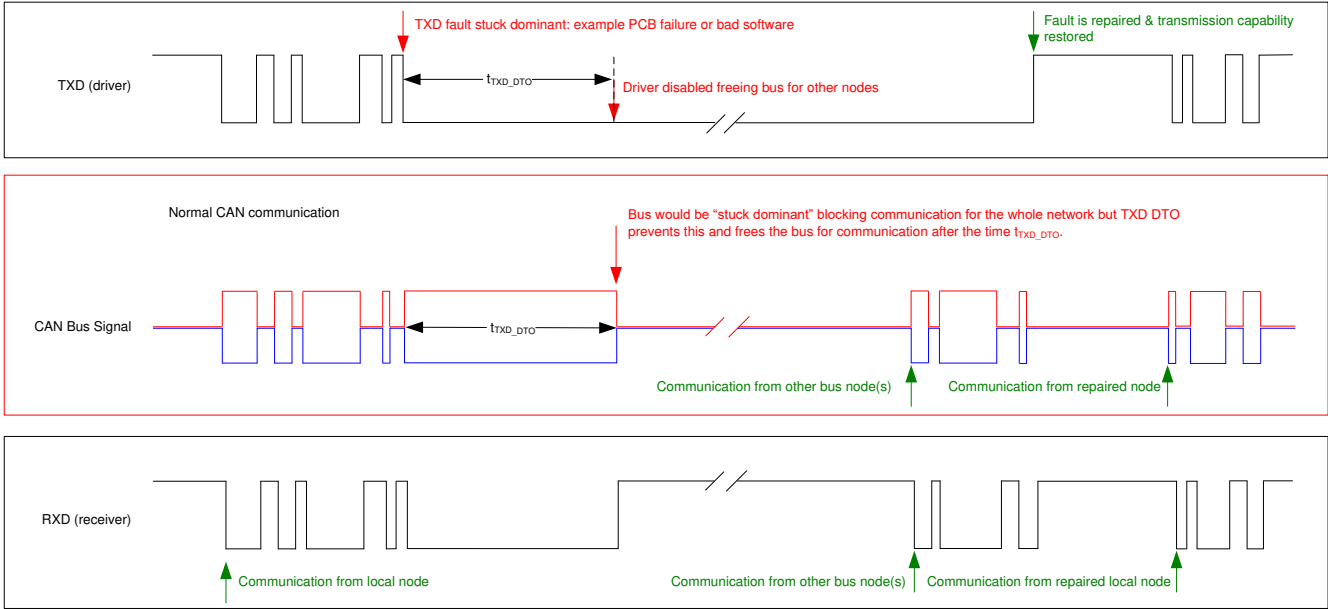

7-6. Example Timing Diagram for TXD Dominant Timeout

7.3.4 CAN Bus Short-circuit Current Limiting

The TCAN1472-Q1 has several protection features that limit the short-circuit current when a CAN bus line is shorted. These include CAN driver current limiting in the dominant and recessive states and TXD dominant state timeout which prevents permanently having the higher short-circuit current of a dominant state in case of a system fault. During CAN communication the bus switches between the dominant and recessive states; thus, the short-circuit current may be viewed as either the current during each bus state or as a DC average current. When selecting termination resistors or a common mode choke for the CAN design the average power rating, $I_{OS(AVG)}$, should be used. The percentage dominant is limited by the TXD DTO and the CAN protocol which has forced state changes and recessive bits due to bit stuffing, control fields, and inter frame space. These make sure there is a minimum amount of recessive time on the bus even if the data field contains a high percentage of dominant bits.

The average short-circuit current of the bus depends on the ratio of recessive to dominant bits and their respective short-circuit currents. The average short-circuit current may be calculated using 式 2.

$$I_{OS(AVG)} = \% \text{ Transmit} \times [(\% \text{ REC_Bits} \times I_{OS(SS)_REC}) + (\% \text{ DOM_Bits} \times I_{OS(SS)_DOM})] + [\% \text{ Receive} \times I_{OS(SS)_REC}] \quad (2)$$

Where:

- $I_{OS(AVG)}$ is the average short-circuit current
- % Transmit is the percentage the node is transmitting CAN messages
- % Receive is the percentage the node is receiving CAN messages
- % REC_Bits is the percentage of recessive bits in the transmitted CAN messages
- % DOM_Bits is the percentage of dominant bits in the transmitted CAN messages
- $I_{OS(SS)_REC}$ is the recessive steady state short-circuit current
- $I_{OS(SS)_DOM}$ is the dominant steady state short-circuit current

This short-circuit current and the possible fault cases of the network are taken into consideration when sizing the power supply used to generate the transceivers V_{CC} supply.

7.3.5 Thermal Shutdown (TSD)

If the junction temperature of the TCAN1472-Q1 exceeds the thermal shutdown threshold, T_{TSD} , the device turns off the CAN driver circuitry and blocks the TXD to bus transmission path. The shutdown condition is cleared when the junction temperature of the device drops below T_{TSD} . The CAN bus pins are biased to $V_{CC}/2$ during a TSD fault and the receiver to RXD path remains operational. The TCAN1472-Q1 TSD circuit includes hysteresis which prevents the CAN driver output from oscillating during a TSD fault.

7.3.6 Undervoltage Lockout

The supply pins, V_{CC} and V_{IO} , have undervoltage detection that places the device into a protected state. This protects the bus during an undervoltage event on either supply pin.

表 7-1. Undervoltage Lockout - TCAN1472-Q1

V_{CC}	DEVICE STATE	BUS	RXD PIN
$> UV_{VCC}$	Normal	Per TXD	Mirrors bus
$< UV_{VCC}$	Protected	High impedance	High impedance

表 7-2. Undervoltage Lockout - TCAN1472V-Q1

V_{CC}	V_{IO}	DEVICE STATE	BUS	RXD PIN
$> UV_{VCC}$	$> UV_{VIO}$	Normal	Per TXD	Mirrors bus
$< UV_{VCC}$	$> UV_{VIO}$	STB = V_{IO} : standby mode	High impedance	V_{IO} : Remote wake request ⁽¹⁾
		STB = GND: Protected		Recessive
$> UV_{VCC}$	$< UV_{VIO}$	Protected		High impedance
$< UV_{VCC}$	$< UV_{VIO}$	Protected		High impedance

(1) See [Remote Wake Request via Wake-Up Pattern \(WUP\) in Standby Mode](#)

Once the undervoltage condition is cleared and t_{MODE} has expired, the TCAN1472-Q1 transitions to normal mode and the host controller can send and receive CAN traffic again.

7.3.7 Unpowered Device

The TCAN1472-Q1 is designed to be a passive or no load to the CAN bus if the device is unpowered. The bus pins were designed to have low leakage currents when the device is unpowered to not load the bus. This is critical if some nodes of the network are unpowered while the rest of the of network remains operational.

The logic pins also have low leakage currents when the device is unpowered to not load other circuits which may remain powered.

7.3.8 Floating pins

The TCAN1472-Q1 has internal pull-ups on critical pins which place the device into known states if the pin floats. This internal bias should not be relied upon by design though, especially in noisy environments, but instead should be considered a failsafe protection feature.

When a CAN controller supporting open-drain outputs is used, an adequate external pull-up resistor must be chosen. Making sures the TXD output of the CAN controller maintains acceptable bit time to the input of the CAN transceiver. See [表 7-3](#) for details on pin bias conditions.

表 7-3. Pin Bias

Pin	Pull-up or Pull-down	Comment
TXD	Pull-up	Weakly biases TXD towards recessive to prevent bus blockage or TXD DTO triggering
STB	Pull-up	Weakly biases STB towards low-power standby mode to prevent excessive system power

7.4 Device Functional Modes

7.4.1 Operating Modes

The TCAN1472-Q1 has two main operating modes; normal mode and standby mode. Operating mode selection is made by applying a high or low level to the STB pin on the TCAN1472-Q1.

表 7-4. Operating Modes

STB	Device Mode	Driver	Receiver	RXD Pin
High	Low current standby mode with bus wake-up	Disabled	Low-power receiver and bus monitor enable	High (recessive) until valid WUP is received. See (1)
Low	Normal Mode	Enabled	Enabled	Mirrors bus state

(1) See [Remote Wake Request via Wake-Up Pattern \(WUP\) in Standby Mode](#)

7.4.2 Normal Mode

This is the normal operating mode of the TCAN1472-Q1. The CAN driver and receiver are fully operational and CAN communication is bi-directional. The driver is translating a digital input on the TXD input to a differential output on the CANH and CANL bus pins. The receiver is translating the differential signal from CANH and CANL to a digital output on the RXD output.

7.4.3 Standby Mode

This is the low-power mode of the TCAN1472-Q1. The CAN driver and main receiver are switched off and bi-directional CAN communication is not possible. The low-power receiver and bus monitor circuits are enabled to allow for RXD wake-up requests via the CAN bus. A wake-up request is output to RXD as shown in [Figure 7-7](#). The local CAN protocol controller should monitor RXD for transitions (high-to-low) and reactivate the device to normal mode by pulling the STB pin low. The CAN bus pins are weakly pulled to GND in this mode (see [Figure 7-4](#) and [Figure 7-5](#)).

In standby mode, only the V_{IO} supply is required therefore the V_{CC} may be switched off for additional system level current savings.

7.4.3.1 Remote Wake Request via Wake-Up Pattern (WUP) in Standby Mode

The TCAN1472-Q1 supports a remote wake-up request that is used to indicate to the host controller that the bus is active and the node should return to normal operation.

The device uses the multiple filtered dominant wake-up pattern (WUP) from the ISO 11898-2:2024 standard to qualify bus activity. Once a valid WUP has been received, the wake request is indicated to the controller by a falling edge and low period corresponding to a filtered dominant on the RXD output of the TCAN1472-Q1.

The Wake-Up Pattern (WUP) comprises four pulses: a filtered dominant, followed by a filtered recessive, then another filtered dominant, and finally another filtered recessive. After the first filtered dominant pulse, the bus monitor waits for a filtered recessive without being reset by other bus traffic and does the same until second filtered recessive pulse. Upon receiving the second filtered recessive pulse, WUP is recognized. RXD is set permanently low upon subsequent dominant pulses.

For a dominant or recessive to be considered filtered, the bus must be in that state for more than the t_{WK_FILTER} time. Due to variability in t_{WK_FILTER} the following scenarios are applicable. Bus state times less than $t_{WK_FILTER(MIN)}$ are never detected as part of a WUP, and therefore, no wake request is generated. Bus state times between $t_{WK_FILTER(MIN)}$ and $t_{WK_FILTER(MAX)}$ may be detected as part of a WUP and a wake-up request may be generated. Bus state times greater than $t_{WK_FILTER(MAX)}$ are always detected as part of a WUP, and thus a wake request is always generated. See [Figure 7-7](#) for the timing diagram of the wake-up pattern.

The pattern and t_{WK_FILTER} time used for the WUP prevents noise and bus stuck dominant faults from causing false wake-up requests while allowing any valid message to initiate a wake-up request.

The ISO 11898-2:2024 standard has defined wake-up filter time to enable 1Mbps arbitration.

For an additional layer of robustness and to prevent false wake-ups, the device implements a wake-up timeout feature. For a remote wake-up event to successfully occur, the entire WUP must be received within the timeout value $t \leq t_{WK_TIMEOUT}$. If not, the internal logic is reset and the transceiver remains in its current state without waking up. The full pattern must then be transmitted again, conforming to the constraints mentioned in this section. See [Figure 7-7](#) for the timing diagram of the wake-up pattern with wake timeout feature.

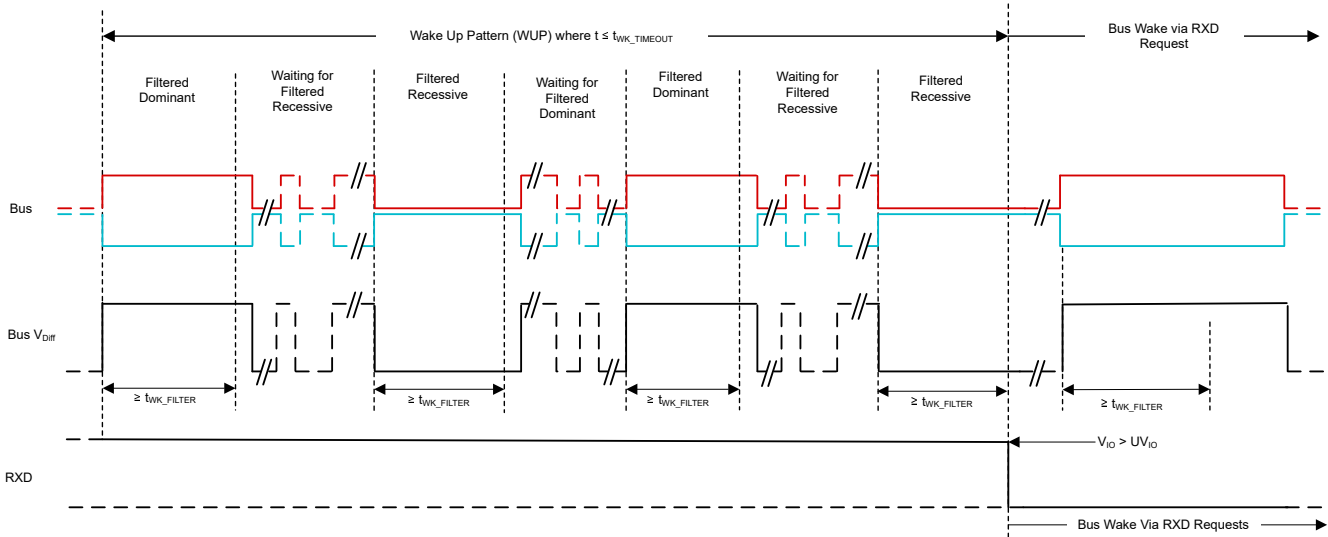

Figure 7-7. Wake-Up Pattern (WUP) with $t_{WK_TIMEOUT}$

7.4.4 Driver and Receiver Function

The digital logic input and output levels for the TCAN1472-Q1 are CMOS levels with respect to V_{CC} . For TCAN1472V-Q1, these are referred to V_{IO} for compatibility with MCUs having 1.8V, 2.5V, 3.3V, or 5V supply.

Table 7-5. Driver Function Table

Device Mode	TXD Input ⁽¹⁾	Bus Outputs		Driven Bus State ⁽²⁾
		CANH	CANL	
Normal	Low	High	Low	Dominant
	High or open	High impedance	High impedance	Biased recessive
Standby	X	High impedance	High impedance	Biased to ground

(1) X = irrelevant

(2) For bus state and bias see [Figure 7-4](#) and [Figure 7-5](#).

Table 7-6. Receiver Function Table Normal and Standby Mode

Device Mode	CAN Differential Inputs $V_{ID} = V_{CANH} - V_{CANL}$	Bus State	RXD Pin
Normal	$V_{ID} \geq 0.9V$	Dominant	Low
	$0.5V < V_{ID} < 0.9V$	Undefined	Undefined
	$V_{ID} \leq 0.5V$	Recessive	High
Standby	$V_{ID} \geq 1.15V$	Dominant	High
	$0.4V < V_{ID} < 1.15V$	Undefined	Low if a remote wake event occurred. See Figure 7-7
	$V_{ID} \leq 0.4V$	Recessive	High
Any	Open ($V_{ID} \approx 0V$)	Open	High

8 Application and Implementation

注

Information in the following applications sections is not part of the TI component specification, and TI does not warrant its accuracy or completeness. TI's customers are responsible for determining suitability of components for their purposes, as well as validating and testing their design implementation to confirm system functionality.

8.1 Application Information

8.2 Typical Application

The TCAN1472-Q1 transceiver can be used in applications with a host controller or FPGA that includes the link layer portion of the CAN protocol.  8-1 shows a typical configuration for 5V controller applications. The bus termination is shown for illustrative purposes.

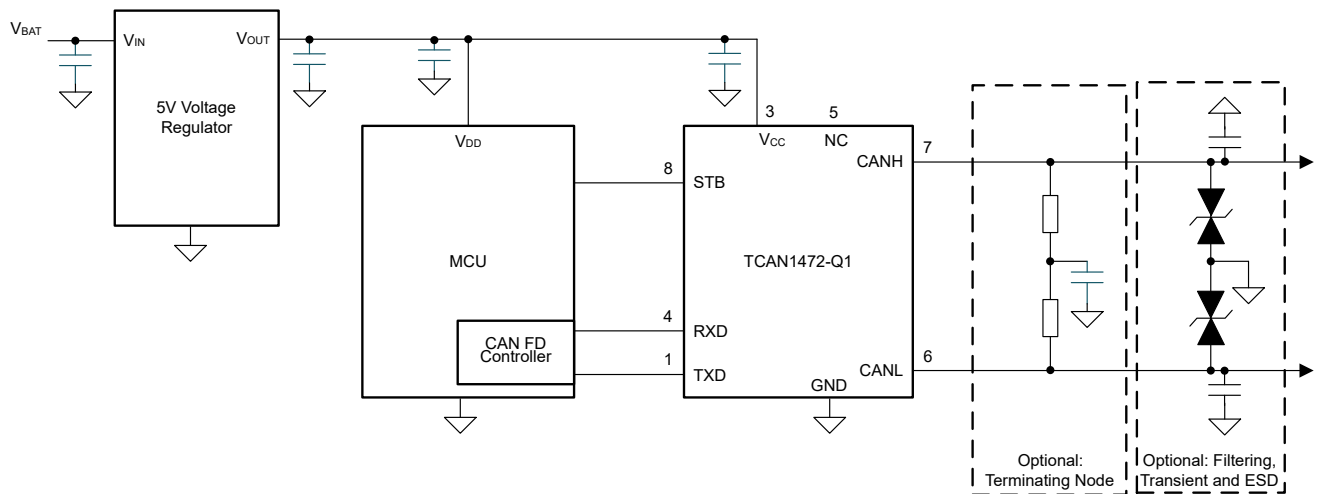

 8-1. Transceiver Application Using 5V I/O Connections

8.2.1 Design Requirements

8.2.1.1 CAN Termination

Termination may be a single 120Ω resistor at each end of the bus, either on the cable or in a terminating node. If filtering and stabilization of the common-mode voltage of the bus is desired then split termination may be used, see [Figure 8-2](#). Split termination improves the electromagnetic emissions behavior of the network by filtering higher-frequency common-mode noise that may be present on the differential signal lines.

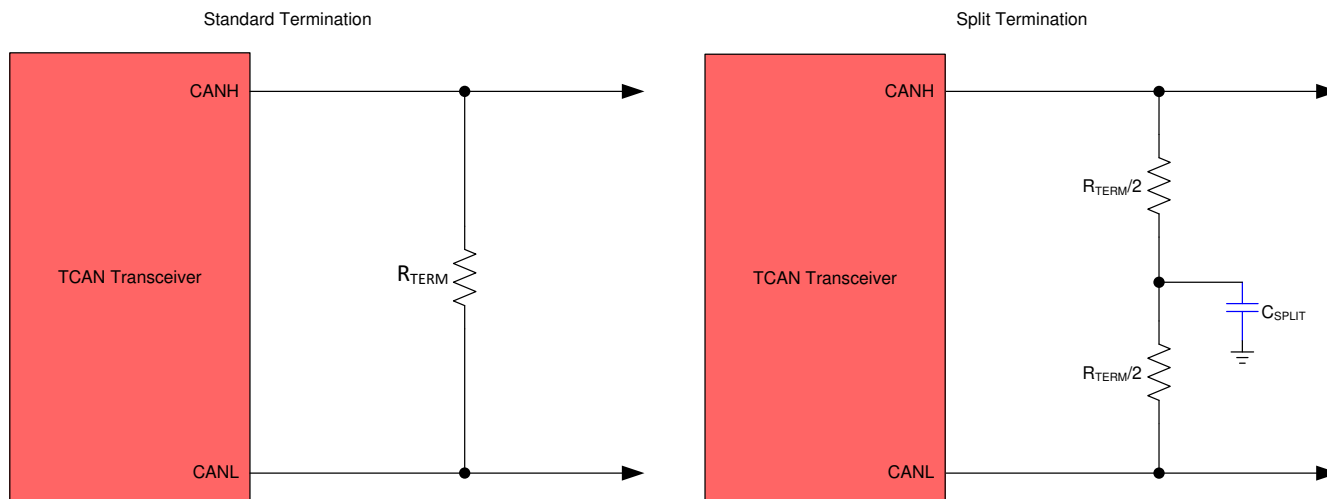

Figure 8-2. CAN Bus Termination Concepts

8.2.2 Detailed Design Procedures

8.2.2.1 Bus Loading, Length and Number of Nodes

A typical CAN application may have a maximum bus length of 40 meters and maximum stub length of 0.3 m. However, with careful design, users can have longer cables, longer stub lengths, and many more nodes to a bus. A high number of nodes requires a transceiver with high input impedance such as the TCAN1472-Q1. Additionally, since TCAN1472V(D)-Q1 has SIC, in a given network size, higher data rate can be achieved because signal ringing is attenuated.

Many CAN organizations and standards have scaled the use of CAN for applications outside the original ISO 11898-2 standard. There are system level trade off decisions for data rate, cable length, and parasitic loading of the bus. Examples of these CAN systems level specifications are ARINC 825, CANopen, DeviceNet, SAE J2284, SAE J1939, and NMEA 2000.

A CAN network system design is a series of tradeoffs. In the ISO 11898-2:2024 specification, the driver differential output is specified with a bus load that can range from 45Ω to 65Ω where the differential output must be greater than 1.5V. The TCAN1472-Q1 family is specified to meet the 1.5V requirement down to 45Ω bus load. The differential input resistance of the TCAN1472-Q1 is a minimum of $40k\Omega$. If 100 TCAN1472-Q1 transceivers are in parallel on a bus, this is equivalent to a 400Ω differential load in parallel with the nominal 60Ω bus termination which gives a total bus load of approximately 52Ω . Therefore, the TCAN1472-Q1 family theoretically supports over 100 transceivers on a single bus segment. However, for a CAN network design margin must be given for signal loss across the system and cabling, parasitic loadings, timing, network imbalances, ground offsets and signal integrity thus a practical maximum number of nodes is often lower. Bus length may also be extended beyond 40 meters by careful system design and data rate tradeoffs. For example, CANopen network design guidelines allow the network to be up to 1km with changes in the termination resistance, cabling, less than 64 nodes and significantly lowered data rate.

This flexibility in CAN network design is one of the key strengths of the various extensions and additional standards that have been built on the original ISO 11898-2 CAN standard. However, when using this flexibility

the CAN network system, the designer must take the responsibility of good network design for a robust network operation.



图 8-3. Typical CAN Bus

ADVANCE INFORMATION

8.3 System Examples

The TCAN1472V(D)-Q1 CAN transceiver is typically used in applications with a host controller or FPGA that includes the link layer portion of the CAN protocol. A 1.8V, 2.5V, or 3.3V application is shown in [Figure 8-4](#). The bus termination is shown for illustrative purposes.

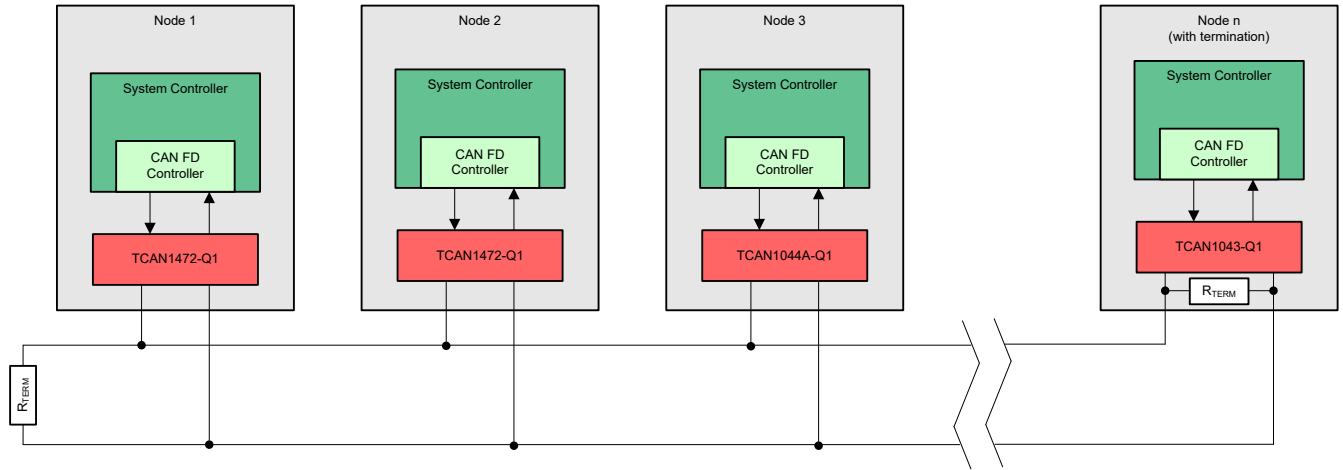
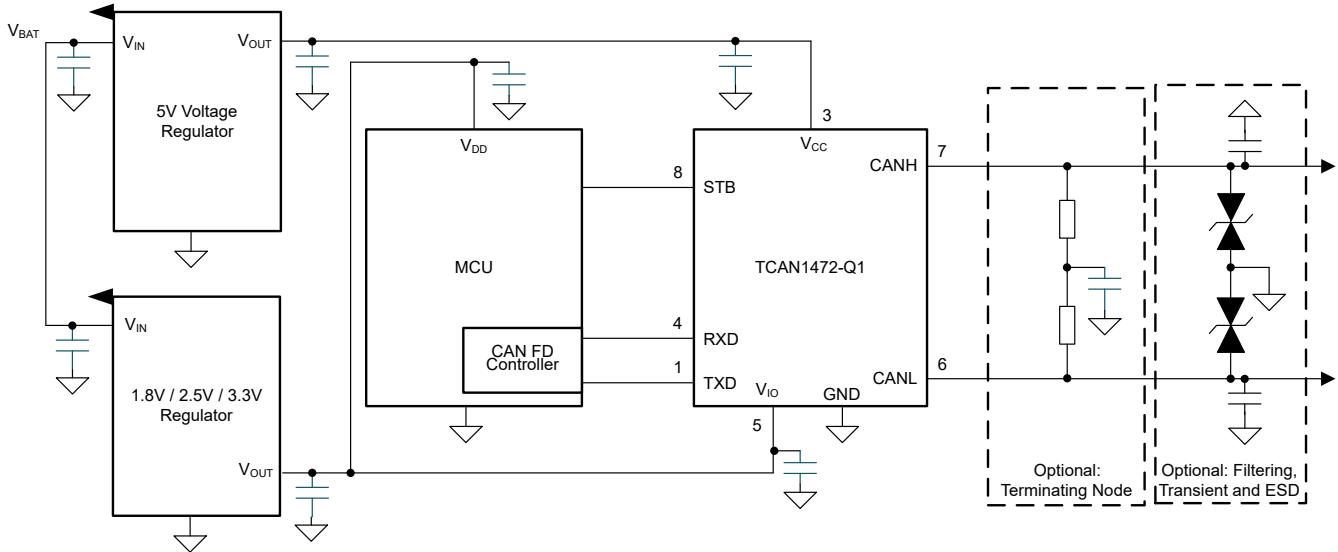

Figure 8-4. Typical Transceiver Application Using 1.8V, 2.5V, 3.3V IO Connections

8.4 Power Supply Recommendations

The TCAN1472-Q1 transceiver is designed to operate with a main V_{CC} input voltage supply range between 4.5V and 5.5V. The TCAN1472V-Q1 implements an I/O level shifting supply input, V_{IO} , designed for a range between 1.8V and 5.5V. Both supply inputs must be well regulated. A decoupling capacitance, typically 100nF, should be placed near the CAN transceiver main V_{CC} supply pin in addition to bypass capacitors. A decoupling capacitor, typically 100nF, should be placed near the CAN transceiver V_{IO} supply pin in addition to bypass capacitors.

8.5 Layout

8.5.1 Layout Guidelines

- Place the protection and filtering circuitry close to the bus connector, J1, to prevent transients, ESD, and noise from propagating onto the board. This layout example shows an optional transient voltage suppression (TVS) diode, D1, which may be implemented if the system-level requirements exceed the specified rating of the transceiver. This example also shows optional bus filter capacitors C4 and C5.
- Design the bus protection components in the direction of the signal path. Do not force the transient current to divert from the signal path to reach the protection device.
- Decoupling capacitors should be placed as close as possible to the supply pins V_{CC} and V_{IO} of transceiver.
- Use at least two vias for supply and ground connections of bypass capacitors and protection devices to minimize trace and via inductance.

注

High frequency current follows the path of least impedance and not the path of least resistance.

- This layout example shows how split termination could be implemented on the CAN node. The termination is split into two resistors, R4 and R5, with the center or split tap of the termination connected to ground via capacitor C3. Split termination provides common mode filtering for the bus. See [CAN Termination](#), and [CAN Bus Short Circuit Current Limiting](#) for information on termination concepts and power ratings needed for the termination resistor(s).

8.5.2 Layout Example



図 8-5. Layout Example

9 Device and Documentation Support

9.1 Receiving Notification of Documentation Updates

To receive notification of documentation updates, navigate to the device product folder on ti.com. In the upper right corner, click on *Alert me* to register and receive a weekly digest of any product information that has changed. For change details, review the revision history included in any revised document.

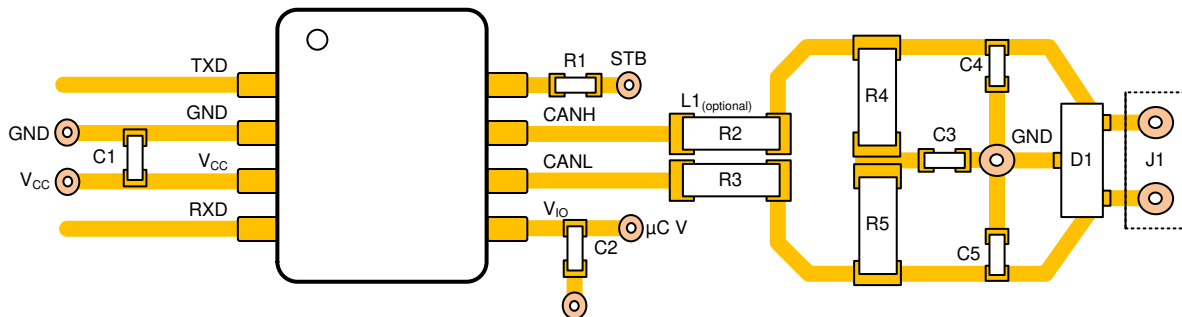
9.2 サポート・リソース

テキサス・インスツルメンツ E2E™ サポート・フォーラムは、エンジニアが検証済みの回答と設計に関するヒントをエキスパートから迅速かつ直接得ることができる場所です。既存の回答を検索したり、独自の質問をしたりすることで、設計に必要な支援を迅速に得ることができます。

リンクされているコンテンツは、各寄稿者により「現状のまま」提供されるものです。これらはテキサス・インスツルメンツの仕様を構成するものではなく、必ずしもテキサス・インスツルメンツの見解を反映したものではありません。テキサス・インスツルメンツの [使用条件](#) を参照してください。

9.3 Trademarks

テキサス・インスツルメンツ E2E™ is a trademark of Texas Instruments.
すべての商標は、それぞれの所有者に帰属します。

9.4 静電気放電に関する注意事項



この IC は、ESD によって破損する可能性があります。テキサス・インスツルメンツは、IC を取り扱う際には常に適切な注意を払うことを推奨します。正しい取り扱いおよび設置手順に従わない場合、デバイスを破損するおそれがあります。

ESD による破損は、わずかな性能低下からデバイスの完全な故障まで多岐にわたります。精密な IC の場合、パラメータがわずかに変化するだけで公表されている仕様から外れる可能性があるため、破損が発生しやすくなっています。

9.5 用語集

[テキサス・インスツルメンツ用語集](#) この用語集には、用語や略語の一覧および定義が記載されています。

10 Revision History

DATE	REVISION	NOTES
June 2024	*	Initial Release

11 Mechanical, Packaging, and Orderable Information

The following pages include mechanical, packaging, and orderable information. This information is the most current data available for the designated devices. This data is subject to change without notice and revision of this document. For browser-based versions of this data sheet, refer to the left-hand navigation.

11.1 Tape and Reel Information

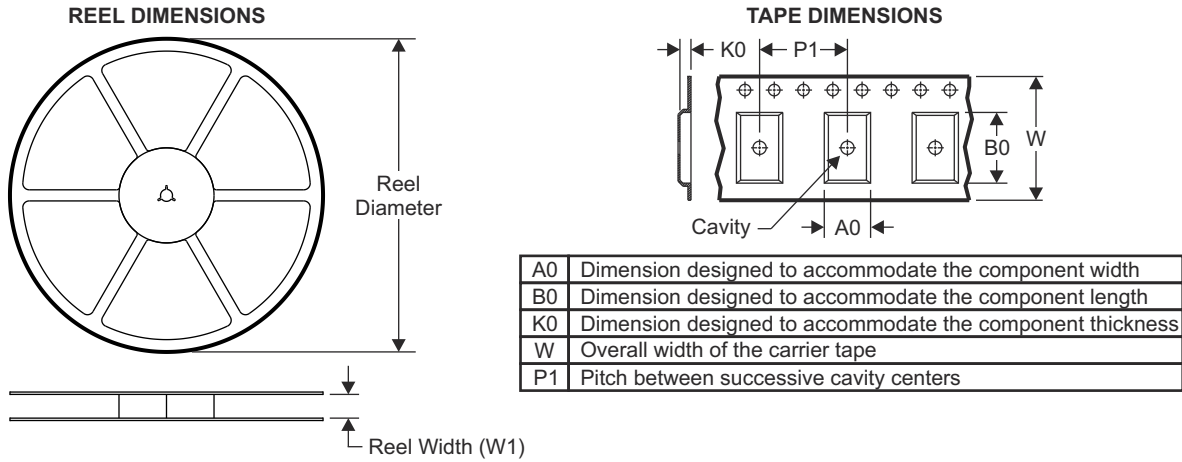

QUADRANT ASSIGNMENTS FOR PIN 1 ORIENTATION IN TAPE

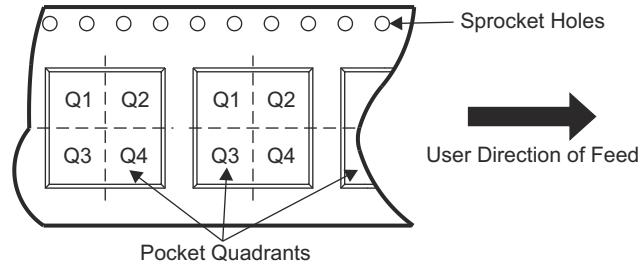

Device	Package Type	Package Drawing	Pins	SPQ	Reel Diameter (mm)	Reel Width W1 (mm)	A0 (mm)	B0 (mm)	K0 (mm)	P1 (mm)	W (mm)	Pin1 Quadrant
TCAN1472DRQ1	SOIC	D	8	2500	330.0	12.5	6.4	5.2	2.1	8.0	12.0	Q2
TCAN1472VDRQ1	SOIC	D	8	2500	330.0	12.5	6.4	5.2	2.1	8.0	12.0	Q2
TCAN1472DDFRQ1	SOT-23	DDF	8	3000	330.0	12.4	3.3	3.3	1.1	8.0	12.0	Q1
TCAN1472VDDFRQ1	SOT-23	DDF	8	3000	330.0	12.4	3.3	3.3	1.1	8.0	12.0	Q1
TCAN1472DRBRQ1	SON	DRB	8	3000	330.0	12.4	3.3	3.3	1.0	8.0	12.0	Q2
TCAN1472VDRBRQ1	SON	DRB	8	3000	330.0	12.4	3.3	3.3	1.0	8.0	12.0	Q2

ADVANCE INFORMATION

TAPE AND REEL BOX DIMENSIONS

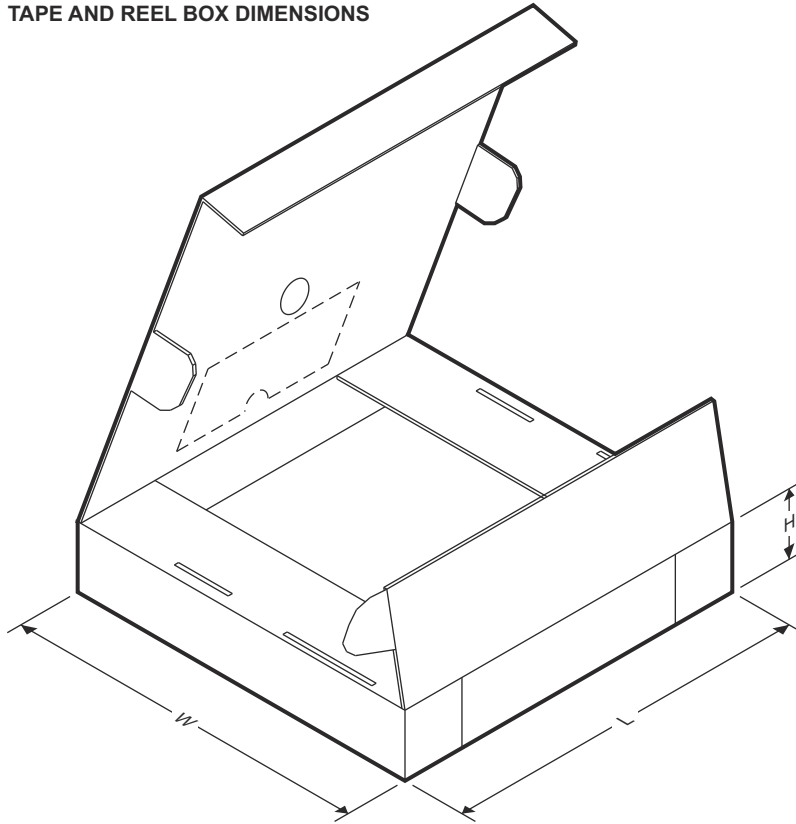

ADVANCE INFORMATION

Device	Package Type	Package Drawing	Pins	SPQ	Length (mm)	Width (mm)	Height (mm)
TCAN1472DRQ1	SOIC	D	8	2500	340.5	336.1	25.0
TCAN1472VDRQ1	SOIC	D	8	2500	340.5	336.1	25.0
TCAN1472DDFRQ1	SOT-23	DDF	8	3000	210.0	185.0	210.0
TCAN1472VDDFRQ1	SOT-23	DDF	8	3000	210.0	185.0	210.0
TCAN1472DRBRQ1	SON	DRB	8	3000	346.0	346.0	35.0
TCAN1472VDRBRQ1	SON	DRB	8	3000	346.0	346.0	35.0



D0008B

PACKAGE OUTLINE
SOIC - 1.75 mm max height

SMALL OUTLINE INTEGRATED CIRCUIT

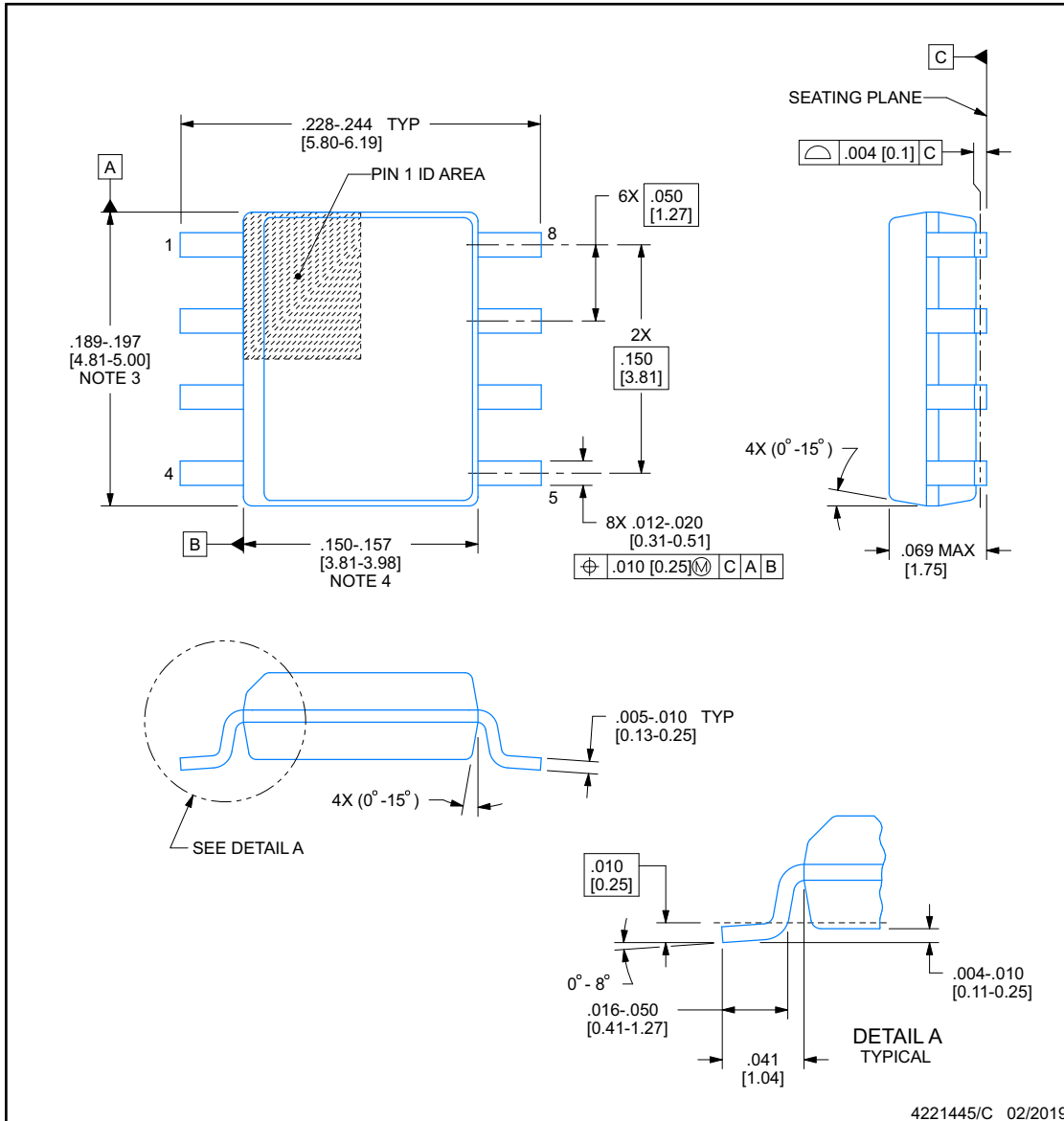

NOTES:

1. Linear dimensions are in inches [millimeters]. Dimensions in parenthesis are for reference only. Controlling dimensions are in inches. Dimensioning and tolerancing per ASME Y14.5M.
2. This drawing is subject to change without notice.
3. This dimension does not include mold flash, protrusions, or gate burrs. Mold flash, protrusions, or gate burrs shall not exceed $.006$ [0.15], per side.
4. This dimension does not include interlead flash.
5. Reference JEDEC registration MS-012, variation AA.

EXAMPLE BOARD LAYOUT

D0008B

SOIC - 1.75 mm max height

SMALL OUTLINE INTEGRATED CIRCUIT

ADVANCE INFORMATION

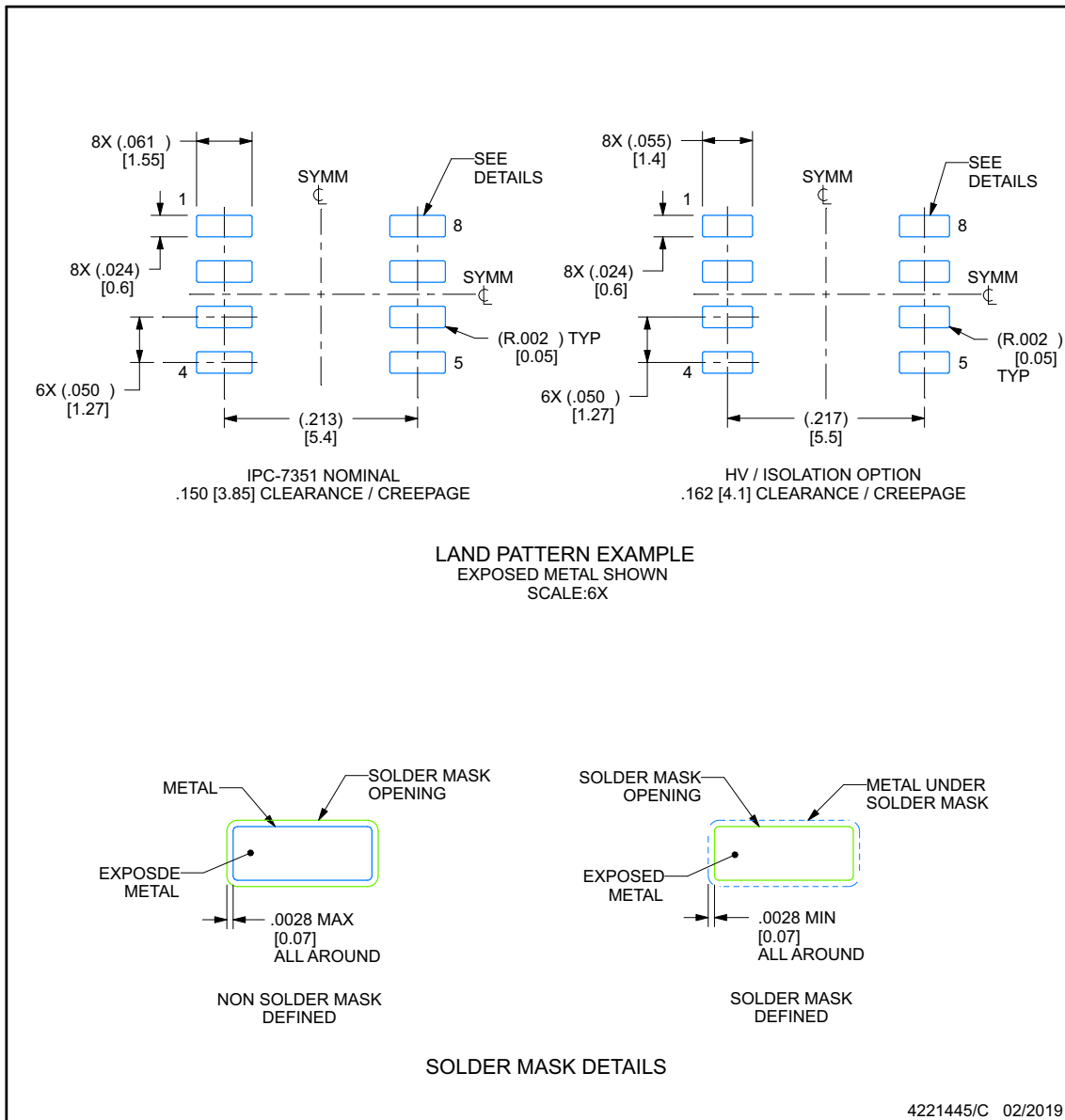

NOTES: (continued)

- 6. Publication IPC-7351 may have alternate designs.
- 7. Solder mask tolerances between and around signal pads can vary based on board fabrication site.

EXAMPLE STENCIL DESIGN

D0008B

SOIC - 1.75 mm max height

SMALL OUTLINE INTEGRATED CIRCUIT

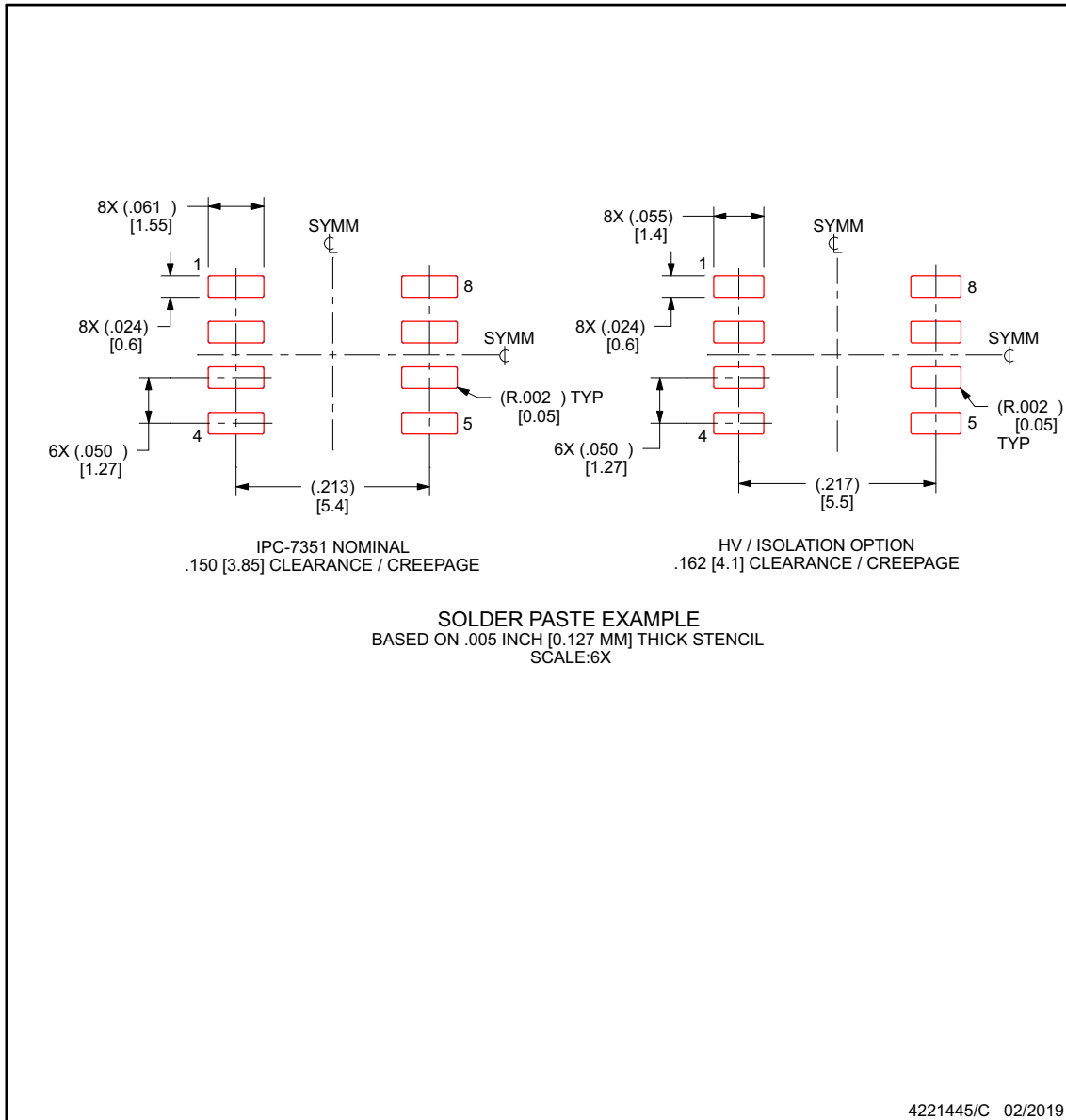

NOTES: (continued)

8. Laser cutting apertures with trapezoidal walls and rounded corners may offer better paste release. IPC-7525 may have alternate design recommendations.
9. Board assembly site may have different recommendations for stencil design.

ADVANCE INFORMATION

DRB0008F



PACKAGE OUTLINE
VSON - 1 mm max height

PLASTIC SMALL OUTLINE - NO LEAD

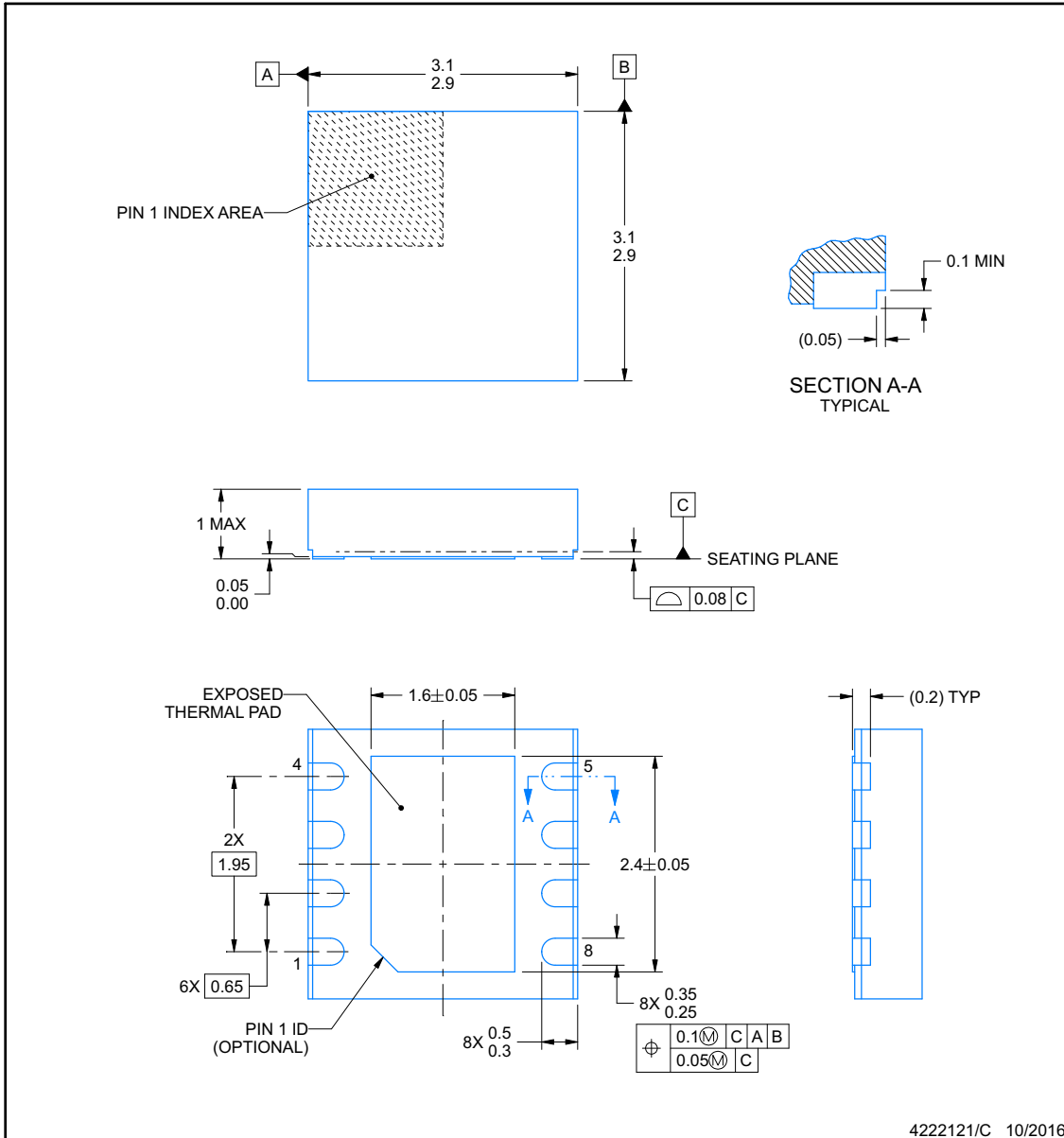

NOTES:

1. All linear dimensions are in millimeters. Any dimensions in parenthesis are for reference only. Dimensioning and tolerancing per ASME Y14.5M.
2. This drawing is subject to change without notice.
3. The package thermal pad must be soldered to the printed circuit board for thermal and mechanical performance.

www.ti.com

EXAMPLE BOARD LAYOUT

DRB0008F

VSON - 1 mm max height

PLASTIC SMALL OUTLINE - NO LEAD

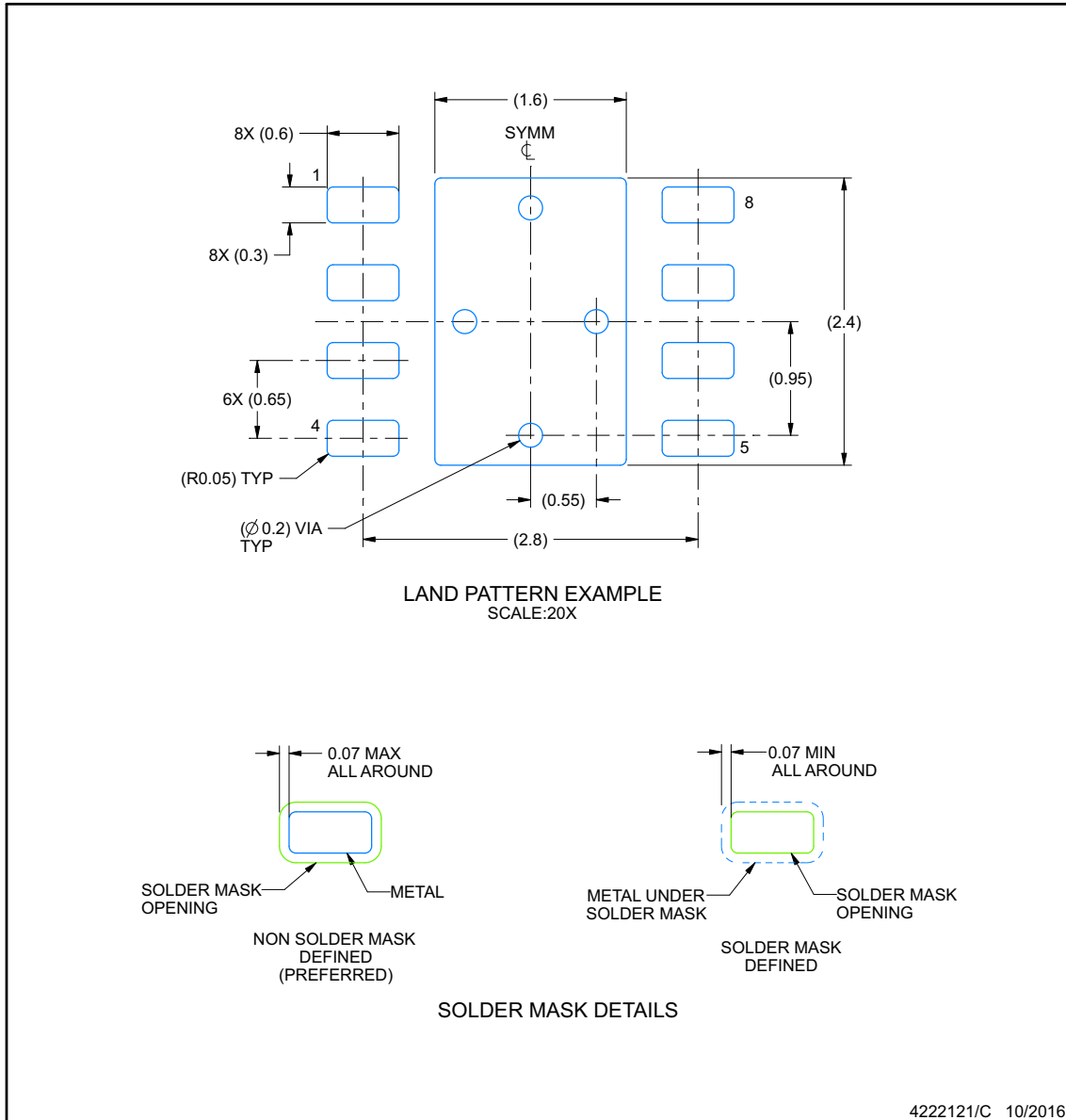

NOTES: (continued)

4. This package is designed to be soldered to a thermal pad on the board. For more information, see Texas Instruments literature number SLUA271 (www.ti.com/lit/sluea271).
5. Vias are optional depending on application, refer to device data sheet. If any vias are implemented, refer to their locations shown on this view. It is recommended that vias under paste be filled, plugged or tented.

www.ti.com

ADVANCE INFORMATION

EXAMPLE STENCIL DESIGN

DRB0008F

VSON - 1 mm max height

PLASTIC SMALL OUTLINE - NO LEAD

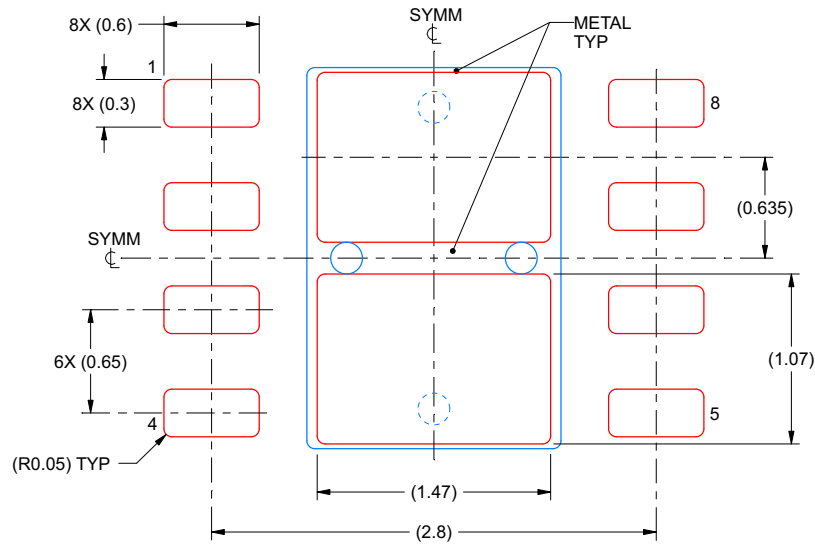

SOLDER PASTE EXAMPLE
 BASED ON 0.125 mm THICK STENCIL

EXPOSED PAD
 82% PRINTED SOLDER COVERAGE BY AREA
 SCALE:25X

4222121/C 10/2016

NOTES: (continued)

6. Laser cutting apertures with trapezoidal walls and rounded corners may offer better paste release. IPC-7525 may have alternate design recommendations.

www.ti.com

ADVANCE INFORMATION



DDF0008A

PACKAGE OUTLINE
SOT-23 - 1.1 mm max height

PLASTIC SMALL OUTLINE

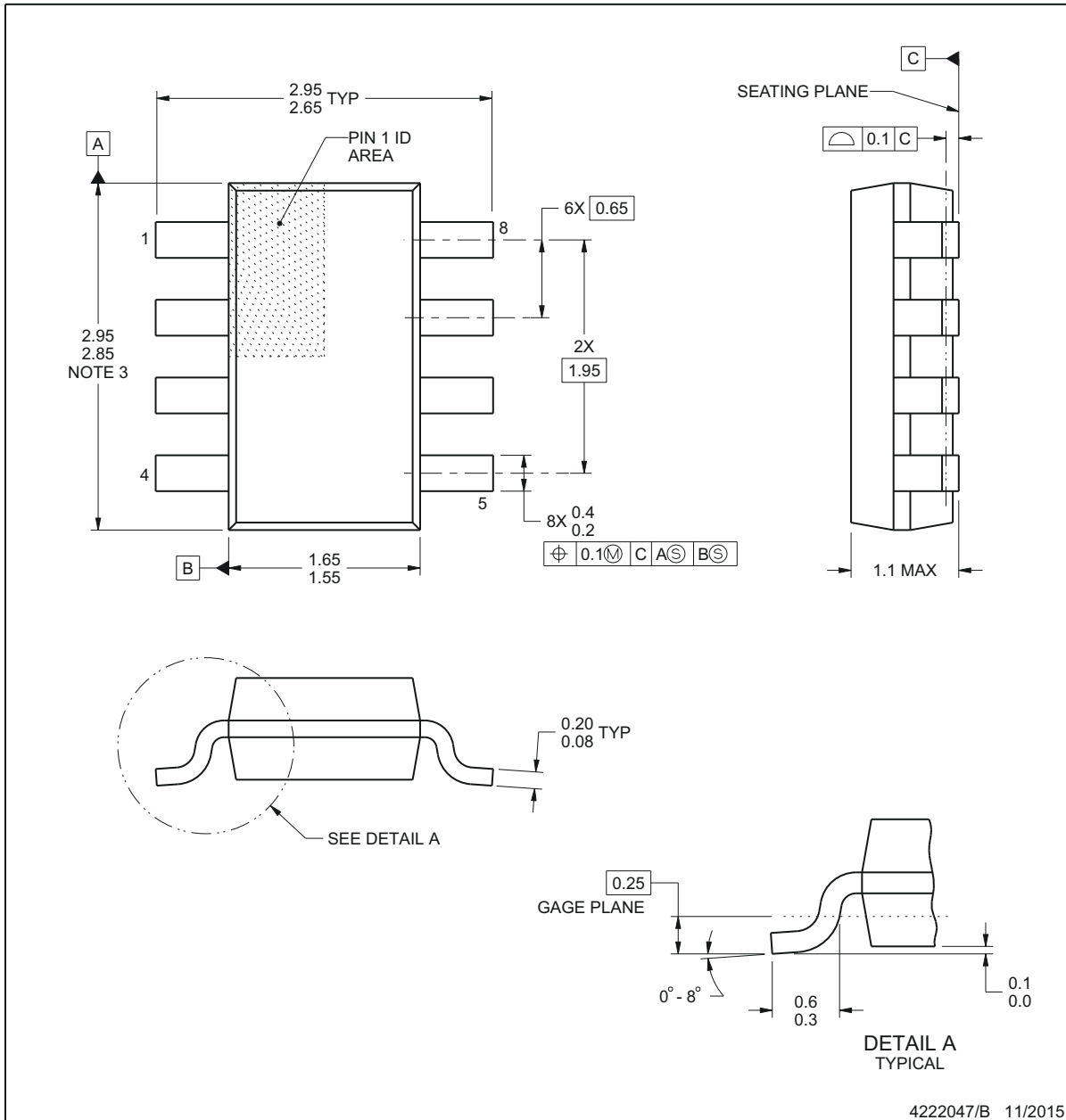

NOTES:

1. All linear dimensions are in millimeters. Any dimensions in parenthesis are for reference only. Dimensioning and tolerancing per ASME Y14.5M.
2. This drawing is subject to change without notice.
3. This dimension does not include mold flash, protrusions, or gate burrs. Mold flash, protrusions, or gate burrs shall not exceed 0.15 mm per side.

ADVANCE INFORMATION

EXAMPLE BOARD LAYOUT

DDF0008A

SOT-23 - 1.1 mm max height

PLASTIC SMALL OUTLINE

ADVANCE INFORMATION

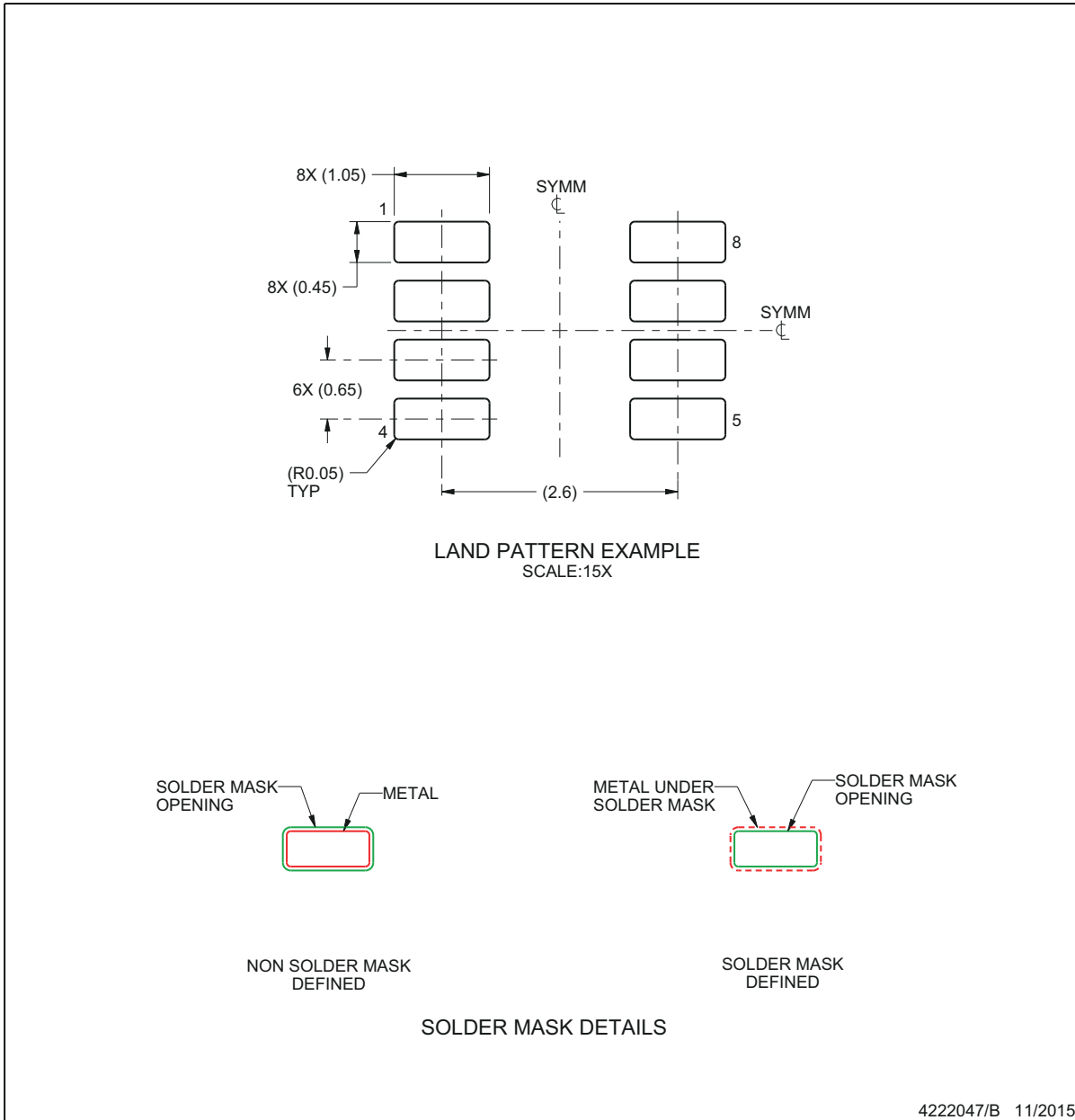

NOTES: (continued)

- Publication IPC-7351 may have alternate designs.
- Solder mask tolerances between and around signal pads can vary based on board fabrication site.

EXAMPLE STENCIL DESIGN

DDF0008A

SOT-23 - 1.1 mm max height

PLASTIC SMALL OUTLINE

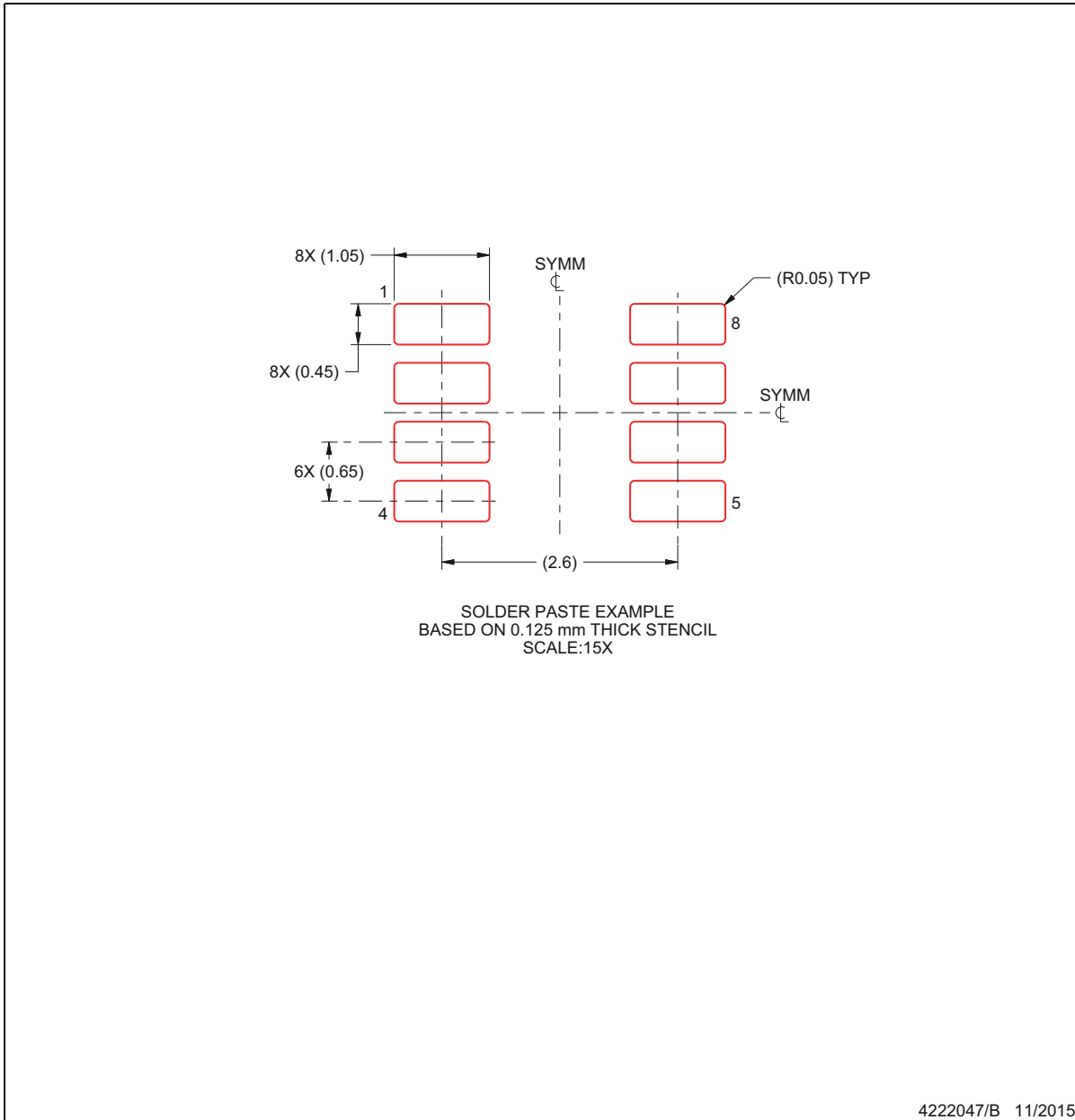

NOTES: (continued)

6. Laser cutting apertures with trapezoidal walls and rounded corners may offer better paste release. IPC-7525 may have alternate design recommendations.
7. Board assembly site may have different recommendations for stencil design.

ADVANCE INFORMATION

重要なお知らせと免責事項

テキサス・インスツルメンツは、技術データと信頼性データ (データシートを含みます)、設計リソース (リファレンス デザインを含みます)、アプリケーションや設計に関する各種アドバイス、Web ツール、安全性情報、その他のリソースを、欠陥が存在する可能性のある「現状のまま」提供しており、商品性および特定目的に対する適合性の黙示保証、第三者の知的財産権の非侵害保証を含むいかなる保証も、明示的または黙示的にかかわらず拒否します。

これらのリソースは、テキサス・インスツルメンツ製品を使用する設計の経験を積んだ開発者への提供を意図したものです。(1) お客様のアプリケーションに適した テキサス・インスツルメンツ製品の選定、(2) お客様のアプリケーションの設計、検証、試験、(3) お客様のアプリケーションに該当する各種規格や、その他のあらゆる安全性、セキュリティ、規制、または他の要件への確実な適合に関する責任を、お客様のみが単独で負うものとします。

上記の各種リソースは、予告なく変更される可能性があります。これらのリソースは、リソースで説明されている テキサス・インスツルメンツ製品を使用するアプリケーションの開発の目的でのみ、テキサス・インスツルメンツはその使用をお客様に許諾します。これらのリソースに関して、他の目的で複製することや掲載することは禁止されています。テキサス・インスツルメンツや第三者の知的財産権のライセンスが付与されている訳ではありません。お客様は、これらのリソースを自身で使用した結果発生するあらゆる申し立て、損害、費用、損失、責任について、テキサス・インスツルメンツおよびその代理人を完全に補償するものとし、テキサス・インスツルメンツは一切の責任を拒否します。

テキサス・インスツルメンツの製品は、[テキサス・インスツルメンツの販売条件](#)、または [ti.com](https://www.ti.com) やかかる テキサス・インスツルメンツ製品の関連資料などのいずれかを通じて提供する適用可能な条項の下で提供されています。テキサス・インスツルメンツがこれらのリソースを提供することは、適用されるテキサス・インスツルメンツの保証または他の保証の放棄の拡大や変更を意味するものではありません。

お客様がいかなる追加条項または代替条項を提案した場合でも、テキサス・インスツルメンツはそれらに異議を唱え、拒否します。

郵送先住所: Texas Instruments, Post Office Box 655303, Dallas, Texas 75265

Copyright © 2024, Texas Instruments Incorporated

PACKAGING INFORMATION

Orderable Device	Status (1)	Package Type	Package Drawing	Pins	Package Qty	Eco Plan (2)	Lead finish/ Ball material (6)	MSL Peak Temp (3)	Op Temp (°C)	Device Marking (4/5)	Samples
PTCAN1472DDFRQ1	ACTIVE	SOT-23-THIN	DDF	8	3000	TBD	Call TI	Call TI	-40 to 150		Samples
PTCAN1472DRBRQ1	ACTIVE	SON	DRB	8	3000	TBD	Call TI	Call TI	-40 to 150		Samples
PTCAN1472DRQ1	ACTIVE	SOIC	D	8	3000	TBD	Call TI	Call TI	-40 to 150		Samples
PTCAN1472VDDFRQ1	ACTIVE	SOT-23-THIN	DDF	8	3000	TBD	Call TI	Call TI	-40 to 150		Samples
PTCAN1472VDRBRQ1	ACTIVE	SON	DRB	8	3000	TBD	Call TI	Call TI	-40 to 150		Samples
PTCAN1472VDRQ1	ACTIVE	SOIC	D	8	3000	TBD	Call TI	Call TI	-40 to 150		Samples

(1) The marketing status values are defined as follows:

ACTIVE: Product device recommended for new designs.

LIFEBUY: TI has announced that the device will be discontinued, and a lifetime-buy period is in effect.

NRND: Not recommended for new designs. Device is in production to support existing customers, but TI does not recommend using this part in a new design.

PREVIEW: Device has been announced but is not in production. Samples may or may not be available.

OBSELETE: TI has discontinued the production of the device.

(2) **RoHS:** TI defines "RoHS" to mean semiconductor products that are compliant with the current EU RoHS requirements for all 10 RoHS substances, including the requirement that RoHS substance do not exceed 0.1% by weight in homogeneous materials. Where designed to be soldered at high temperatures, "RoHS" products are suitable for use in specified lead-free processes. TI may reference these types of products as "Pb-Free".

RoHS Exempt: TI defines "RoHS Exempt" to mean products that contain lead but are compliant with EU RoHS pursuant to a specific EU RoHS exemption.

Green: TI defines "Green" to mean the content of Chlorine (Cl) and Bromine (Br) based flame retardants meet JS709B low halogen requirements of <=1000ppm threshold. Antimony trioxide based flame retardants must also meet the <=1000ppm threshold requirement.

(3) MSL, Peak Temp. - The Moisture Sensitivity Level rating according to the JEDEC industry standard classifications, and peak solder temperature.

(4) There may be additional marking, which relates to the logo, the lot trace code information, or the environmental category on the device.

(5) Multiple Device Markings will be inside parentheses. Only one Device Marking contained in parentheses and separated by a "~" will appear on a device. If a line is indented then it is a continuation of the previous line and the two combined represent the entire Device Marking for that device.

(6) Lead finish/Ball material - Orderable Devices may have multiple material finish options. Finish options are separated by a vertical ruled line. Lead finish/Ball material values may wrap to two lines if the finish value exceeds the maximum column width.

Important Information and Disclaimer: The information provided on this page represents TI's knowledge and belief as of the date that it is provided. TI bases its knowledge and belief on information provided by third parties, and makes no representation or warranty as to the accuracy of such information. Efforts are underway to better integrate information from third parties. TI has taken and continues to take reasonable steps to provide representative and accurate information but may not have conducted destructive testing or chemical analysis on incoming materials and chemicals. TI and TI suppliers consider certain information to be proprietary, and thus CAS numbers and other limited information may not be available for release.

In no event shall TI's liability arising out of such information exceed the total purchase price of the TI part(s) at issue in this document sold by TI to Customer on an annual basis.

重要なお知らせと免責事項

TI は、技術データと信頼性データ (データシートを含みます)、設計リソース (リファレンス・デザインを含みます)、アプリケーションや設計に関する各種アドバイス、Web ツール、安全性情報、その他のリソースを、欠陥が存在する可能性のある「現状のまま」提供しており、商品性および特定目的に対する適合性の黙示保証、第三者の知的財産権の非侵害保証を含むいかなる保証も、明示的または黙示的にかかわらず拒否します。

これらのリソースは、TI 製品を使用する設計の経験を積んだ開発者への提供を意図したものです。(1) お客様のアプリケーションに適した TI 製品の選定、(2) お客様のアプリケーションの設計、検証、試験、(3) お客様のアプリケーションに該当する各種規格や、その他のあらゆる安全性、セキュリティ、規制、または他の要件への確実な適合に関する責任を、お客様のみが単独で負うものとし、

上記の各種リソースは、予告なく変更される可能性があります。これらのリソースは、リソースで説明されている TI 製品を使用するアプリケーションの開発の目的でのみ、TI はその使用をお客様に許諾します。これらのリソースに関して、他の目的で複製することや掲載することは禁止されています。TI や第三者の知的財産権のライセンスが付与されている訳ではありません。お客様は、これらのリソースを自身で使用した結果発生するあらゆる申し立て、損害、費用、損失、責任について、TI およびその代理人を完全に補償するものとし、TI は一切の責任を拒否します。

TI の製品は、[TI の販売条件](#)、または [ti.com](#) やかかる TI 製品の関連資料などのいずれかを通じて提供する適用可能な条項の下で提供されています。TI がこれらのリソースを提供することは、適用される TI の保証または他の保証の放棄の拡大や変更を意味するものではありません。

お客様がいかなる追加条項または代替条項を提案した場合でも、TI はそれらに異議を唱え、拒否します。

郵送先住所 : Texas Instruments, Post Office Box 655303, Dallas, Texas 75265
Copyright © 2024, Texas Instruments Incorporated