

Using THVD80x0 Devices to Communicate Over an AC Outlet



Parker Dodson, Hao Liu

ABSTRACT

The THVD8000 and THVD8010 are RS-485 Transceivers that use OOK modulation to transmit data over a power line by coupling the high frequency signal with either AC or DC power. However, the device cannot drive a power line with less than 375 Ω and cannot take the direct high voltage signal on its communication pins. This proves to be a significant barrier when trying to use this device to communicate power over 110 V AC outlet. This barrier is not insurmountable and this application note will detail the process on how to use the THVD8000/THVD8010 in an application that can transfer data over a 110 V AC outlet as well as give a general guideline for higher voltage AC or DC systems.

Table of Contents

1 Introduction	3
2 THVD80x0 Devices Theory of Operation and Limitations of Use	5
2.1 Overview and Similarities between Standard RS-485 Transceivers and THVD80xo Devices.....	5
2.2 Differences between Standard RS-485 Transceivers and THVD8000/8010.....	5
2.3 Standard Approach to Using THVD80xo Devices to Communicate over Power Lines	6
2.4 Drawbacks to Standard Approach with Higher Voltage Systems.....	7
3 Integration of Line Driver with THVD80x0 Devices to Drive Low Impedance Loads	9
3.1 Overcoming Drive Strength Requirement with A Line Driver Amplifier.....	9
3.2 Modification to Typical System Signal Chain Path Through Integration of Line Driver.....	9
4 High Voltage Interface and Communication Interface Power Supply	11
4.1 Line Driver Output and Input RX signal Protection Circuit.....	11
4.2 High-Voltage Interface.....	12
4.3 Receive Path Optional Bandpass.....	13
5 System Level View and Relation to Higher Voltage Implementations	14
5.1 Powering the Powerline Communication System.....	14
5.2 System Overview with Selected Test Results	14
5.3 Changes to Design for Higher Voltage AC or DC Applications.....	18
6 Summary	18
7 References	19

List of Figures

Figure 1-1. System Implementation 1.....	3
Figure 1-2. System Implementation 2.....	4
Figure 2-1. THVD80x0 Pinout.....	5
Figure 2-2. Standard Approach to Powerline Communication with THVD80x0 Operating in True Differential Mode.....	6
Figure 2-3. Standard Approach to Powerline Communication with THVD80x0 in Pseud0-Differential Mode.....	7
Figure 3-1. Integration of 2x THVD80x0 Devices with THS6222.....	9
Figure 3-2. Integration of 1 THVD80x0 Device with THS6222.....	10
Figure 4-1. Protection Circuit for Line Driver and Transceivers.....	11
Figure 4-2. HV Interface for High Voltage/Low Impedance AC Power Lines.....	12
Figure 4-3. HV Interface Equivalent Circuit.....	12
Figure 4-4. Bandpass Circuit Design.....	13
Figure 5-1. THVD8000 Schematic.....	14
Figure 5-2. THS6222 Schematic.....	15
Figure 5-3. Protection/Bandpass/HV Interface Schematic.....	15

Figure 5-4. Power Tree Schematic.....	15
Figure 5-5. THVD8000 RX and TX signals; THS6222 Transmitting Signals.....	16
Figure 5-6. THVD8000 RX and TX signals; THS6222 Transmitting Signals - Zoomed Out.....	16
Figure 5-7. TX/RX data Overlaid on VAC Signal.....	17
Figure 5-8. TX/RX data Overlaid on VAC Signal Zoomed In.....	17
Figure 5-9. THVD8000 RX Signal on "A" Pin.....	17

List of Tables

Table 2-1. THVD8000 Modulation Frequency Resistance Chart.....	5
Table 2-2. THVD8010 Modulation Frequency Resistance Chart.....	6
Table 3-1. System Configurations.....	10
Table 5-1. High AC Voltage Interface Components.....	16

Trademarks

All trademarks are the property of their respective owners.

1 Introduction

This document will explore how to use the THVD8000/8010 in high voltage applications. First, the THVD8000/8010 basic use will be explained – as this information remains constant across use cases for these devices. Next an explanation of how the integration of a line driver, such as the THS6222, onto the differential bus pins of the THVD8000/8010 will allow the driving of power line loads less than 375 Ω. Then the high voltage interface and the power supply for the communication interface will be shown and what considerations need to be made for this system. Finally, an integrated view of the system with power sources shown as well as the base concept on how to use these ideas to interface with higher than 110 V / 220 V AC and high voltage DC applications with the THVD8000/8010.

Figure 1-1 and Figure 1-2 show two possible architectures for implementing RS-485 communication over low impedance - down to 1 Ω - power lines. Both architectures are independent of powerline voltage as long as the high voltage (HV) interface can isolate the communication lines from the direct power lines of the system.

Figure 1-1, details a block diagram using two separate THVD8000/THVD8010 devices; one device for transmitting data and the other for receiving data.

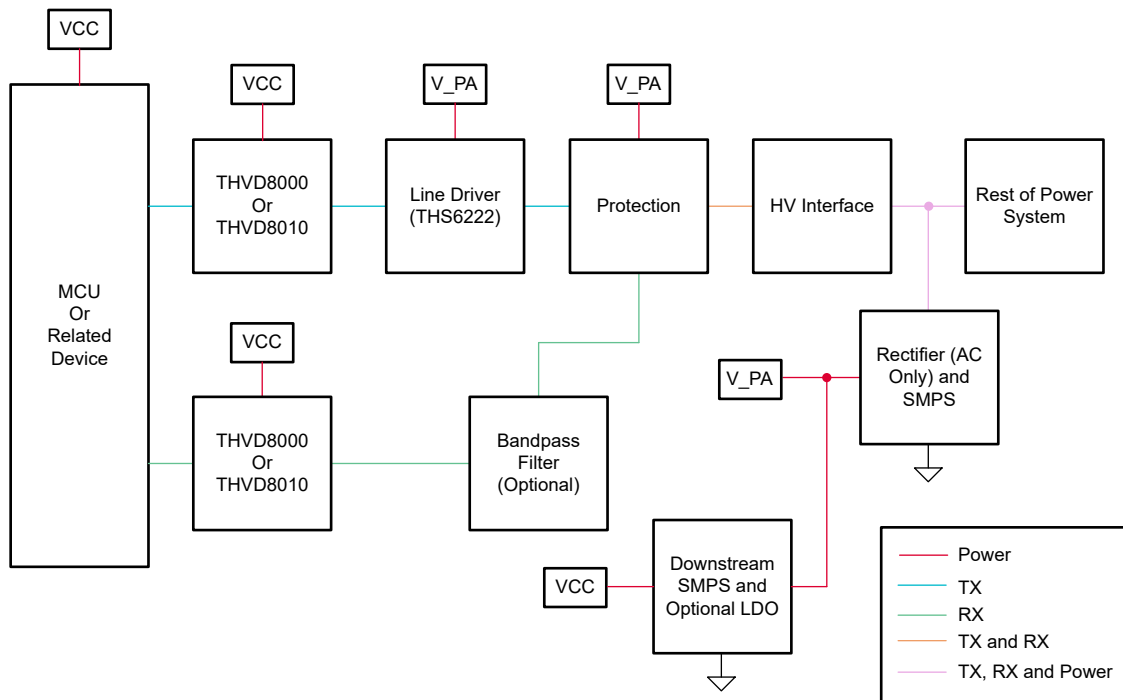

Figure 1-1. System Implementation 1

This implementation is recommended as it has the most favorable layout since the TX and RX path are inherently different due to the line driver; however, with 2 transceivers the BOM cost will increase. Another drawback is that even with two separate transceivers the system still operates in a half-duplex mode.

Figure 1-2 offers an alternative architecture that can reduce BOM cost by only using one THVD8000/THVD8010 device.

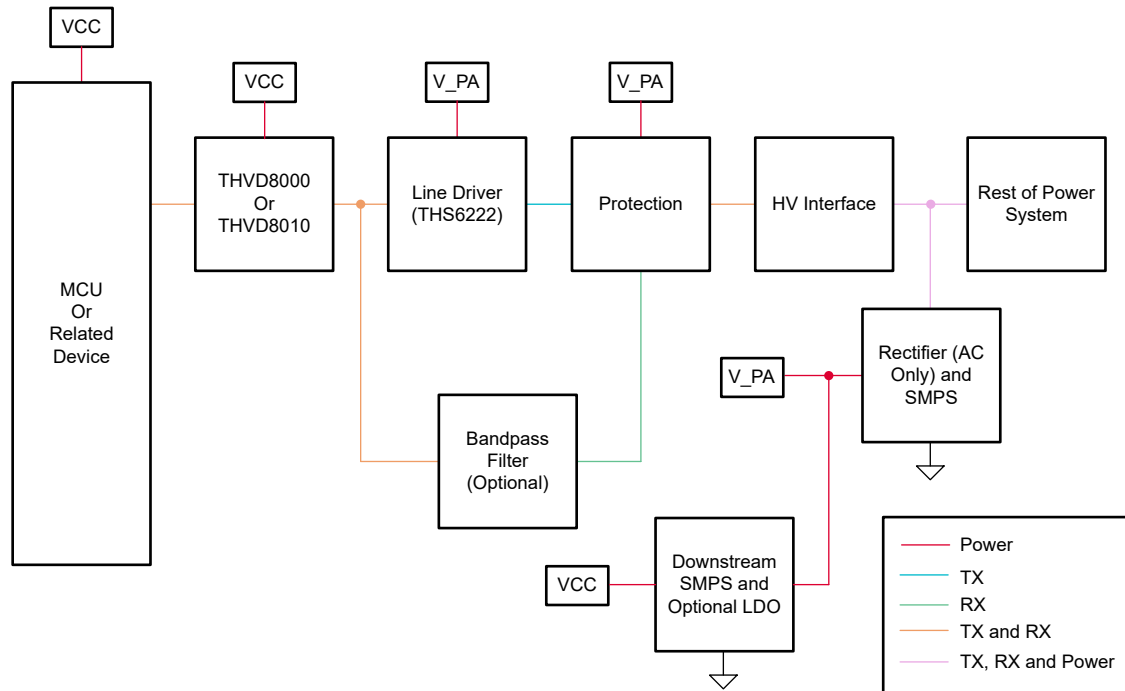

Figure 1-2. System Implementation 2

In cost sensitive applications the smaller BOM is ideal. However, this architecture comes with the draw back of a more complicated layout as the driver will have to drive two paths independently of one another – so the engineering effort and design complexity does increase with this implementation with possible reduced performance.

2 THVD80x0 Devices Theory of Operation and Limitations of Use

2.1 Overview and Similarities between Standard RS-485 Transceivers and THVD80xo Devices

The THVD8000 and 8010 are RS-485 compliant transceivers that use OOK modulation on the input data to transmit data across a power line. This converts a logic 0 into a pulse train with a pre-selected frequency and a logic 1 into a flat output ($V_B - V_A \sim 0V$). Due to this part's added features the pinout is different from a standard half duplex RS-485 device; a pinout is shown in [Figure 2-1](#) for both devices.

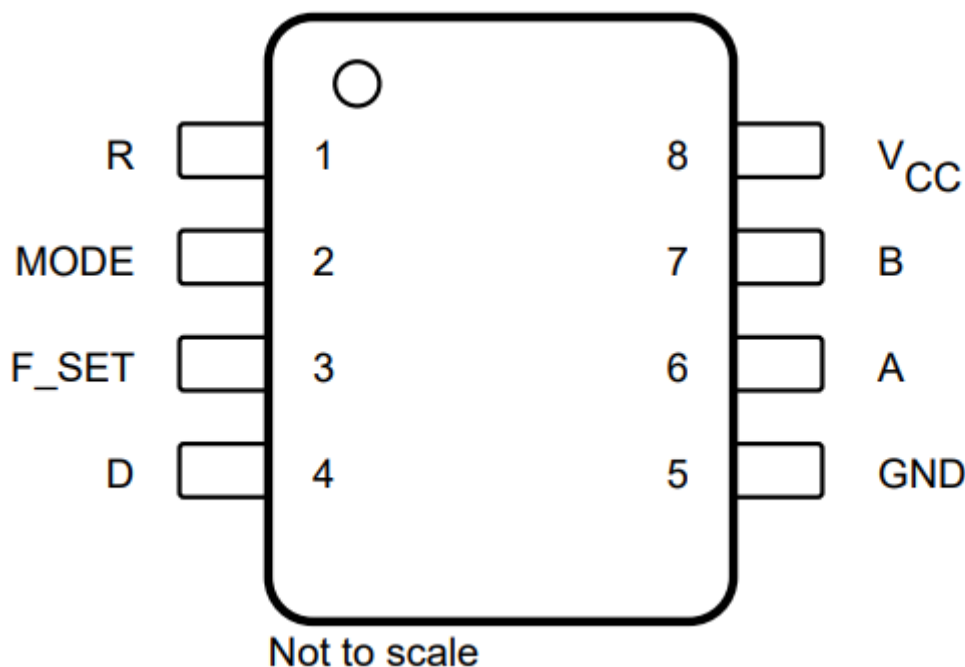

Figure 2-1. THVD80x0 Pinout

The similarities between a standard RS-485 half duplex transceiver and the THVD8000 and THVD8010 parts can be seen in [Figure 2-1](#). Pins 1, 4, 5, and 8 remain similar across most RS-485 devices. Pins 8 and 5 are the power connections to the IC, while pins 1 and 4 are the single ended RX output and TX inputs respectively. The B and A pins are still used for differential communication as in other RS-485 devices and still conform to the 1.5 V differential voltage over a 54 Ω ; however, the A/B pins use OOK modulation instead of a typical pulse train used in RS-485.

2.2 Differences between Standard RS-485 Transceivers and THVD8000/8010

However, the similarities stop at this point. From the single ended side there are two pins that aren't in most RS-485 Transceivers. The F_SET pin is used to select the carrier frequency of the OOK modulation; a resistor to ground will set the value of the carrier frequency – the tables for the 8000 and 8010 are shown in [Table 2-1](#) and [Table 2-2](#) respectively.

Table 2-1. THVD8000 Modulation Frequency Resistance Chart

R _{F_SET} (K Ω)	OOK f ₀ (kHz)
77	125
50	187.5
19	500
12.5	750
9.3	1000
4.4	2000
1.5	5000

Table 2-2. THVD8010 Modulation Frequency Resistance Chart

R _{F_SET} (K Ω)	OOK f ₀ (kHz)
77	125
50	187.5
31.9	300

For best data integrity have the data rate be at least 10 times lower than the carrier frequency. So, if a 125KHz carrier signal is used the data rate should be no faster than the 12.5 Kbps. Higher carrier frequencies also can enable smaller capacitors and inductors in other parts of the circuit reducing board space needed. Next is the MODE pin – this acts as one enable for the device – a low level means the device is in RX mode while a high signal signifies the device is in TX mode.

On the differential communication side, the differences come down to two items. The first is that polarity is now unimportant as the THVD8000/8010 when receiving data reads active pulse trains as 0's and no active signals a logic 1 so a polarity flip between A and B will not interfere with communication. The second is that transition times and mode change delays are related to the carrier frequency chosen this along with the extra modulation and demodulation circuitry can cause this device to not reach as high of data rates, but with the benefit of transferring data over power lines.

2.3 Standard Approach to Using THVD80xo Devices to Communicate over Power Lines

When interfacing the THVD8000/8010 to a power line the general idea is very straightforward – couple the data signal into the power signal and ensure that the data can be recovered at the other end without exposing the THVD8000/8010 to dangerous high voltages. This is done by adding series capacitors to the A and B lines for each transceiver while protecting the power supply and power load with inductors. The basic differential setup is shown below in [Figure 2-2](#) and a basic single ended setup is shown in [Figure 2-3](#).

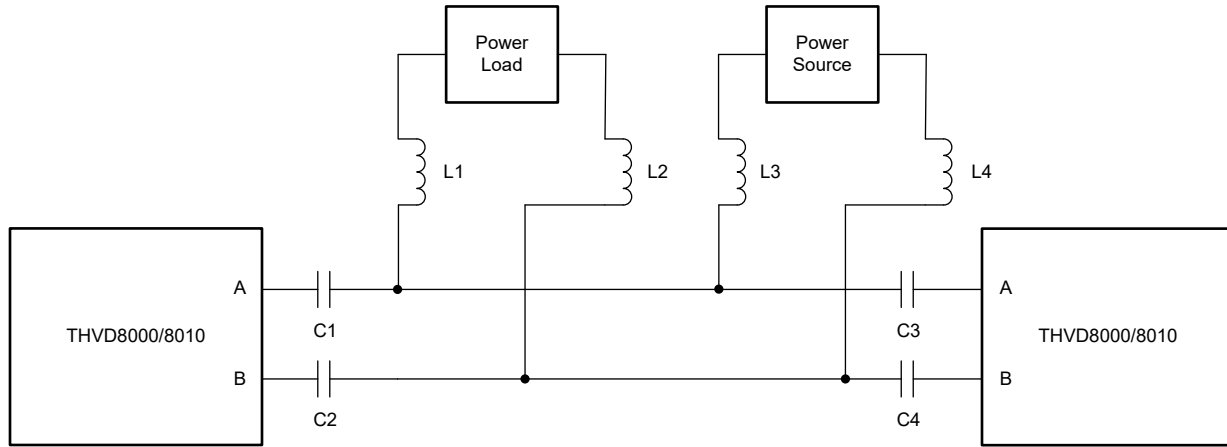

Figure 2-2. Standard Approach to Powerline Communication with THVD80x0 Operating in True Differential Mode

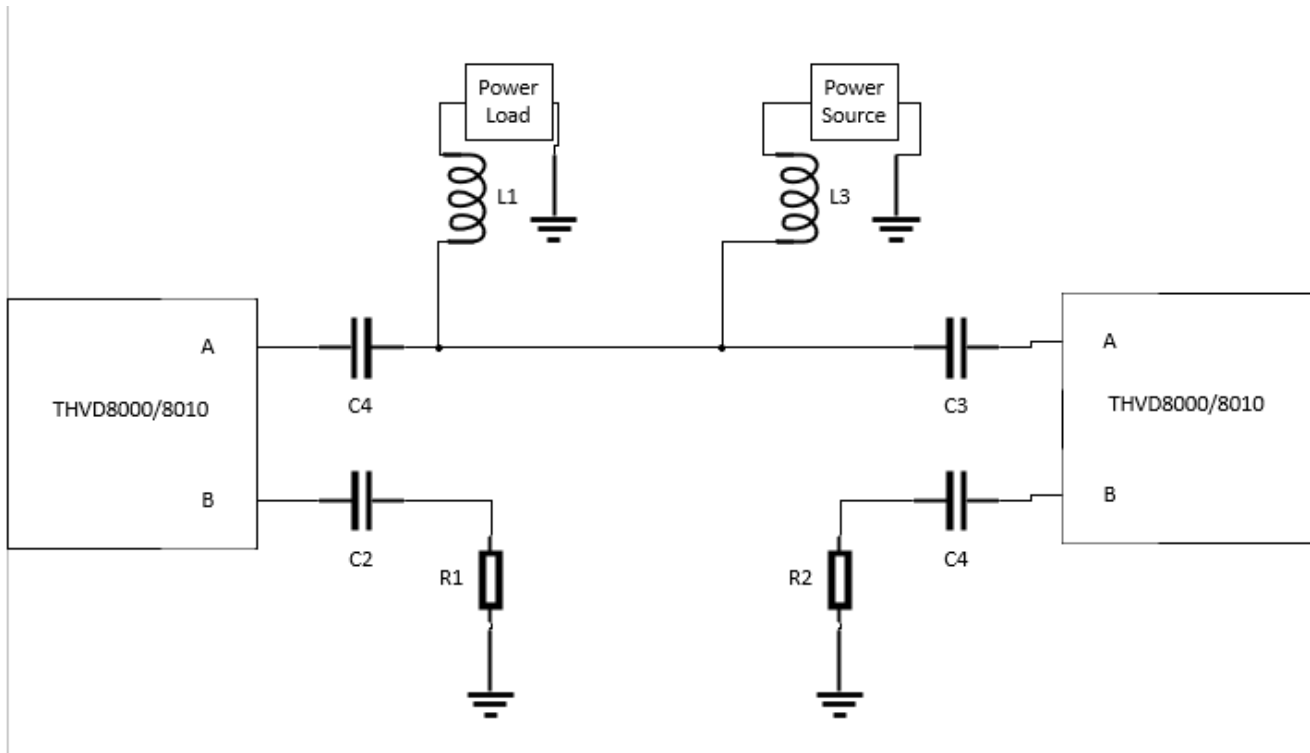

Figure 2-3. Standard Approach to Powerline Communication with THVD80x0 in Pseud0-Differential Mode

Both single ended and differential implementations use the same formulas for capacitors and inductors. The capacitors should have an impedance magnitude of $5\ \Omega$ or less at the OOK modulation frequency to minimize attenuation of the data signal. The inductors are treated as a component from either the A or B line to AC ground, even in instances where the power signal is AC. This assumption can be made as the system under normal operating conditions operates in a linear manner allowing the principle of super-position to hold when sizing inductors. The total impedance magnitude of all inductors in parallel needs to be $375\ \Omega$ or more to ensure proper communication thresholds are reached at the RX side of the power line. The $375\ \Omega$ parameter comes from the RS-485 standard which allows 32 unit loads in parallel on the same line with each of those 32 units loads having a minimum input impedance of $12\text{K}\ \Omega$. At 32 unit loads in parallel the effective impedance to ground is $375\ \Omega$ per line, which is $12\text{K}\ \Omega / 32$. By sizing the capacitors and inductors this way most high frequency energy will be delivered from TX to RX while the power signal's energy mainly stays on the power line and is routed through the inductors. For reference on lower voltage power line communication using the THVD8000 please see the [THVD8000 Design Guide](#).

However, for higher voltage and lower impedance power systems, this method has a few drawbacks that make this type of implementation not a valid solution.

2.4 Drawbacks to Standard Approach with Higher Voltage Systems

The standard approach works great for lower power systems – but there are two main drawbacks that limit this approach in higher voltage, low impedance applications which are drive strength and circuit protection.

The first major drawback is the drive strength of the circuit. In the standard approach this is handled by ensuring that the inductors total impedance in parallel is equal to or greater than $375\ \Omega$ at the OOK modulation frequency. While this is not impossible to meet since the OOK frequency should be much greater than the power signal's frequency it does require much better inductors as they will need to be able to handle the larger current in high power systems while at the same time have low DCR to ensure as little as attenuation as possible in these higher power systems. Also, since most of the higher voltage applications are using some frequency (typically $50\ \text{Hz} - 60\ \text{Hz}$) in the power signal – these inductors will also have frequency related attenuation across the inductors which could be prove problematic from a power delivery standpoint as more attenuation is being added in the line. So, the system complexity can increase due to the lack of drive strength of the THVD8000/8010.

The next drawback is protection. The THVD8000/8010 operates normally with a common mode voltage level of between -7 V and 12 V. These pins can also protect against damage with DC protection up to ± 18 V. It is standard practice to add protection diodes to the TVS lines – which works great by themselves in lower power applications. However, they do not react instantly and there is a small frame of time where the device could be exposed to higher voltages. In lower power applications this isn't a typical concern and a TVS diode is a suitable protection option. When working with voltages at the scale of 110 V AC and higher that reaction time of the diodes may be too long and the THVD8000/8010 will be hit with a high voltage signal and could damage the part. A more robust protection scheme must also be considered if this drawback is to be overcome.

While these drawbacks seem to create many issues with the standard approach, these drawbacks can be overcome with a different approach. Using a few different sub-circuits to increase the drive strength of the THVD8000/8010 as well as offer better protection from the dangerous high voltage signal will allow this device in higher voltage applications.

3 Integration of Line Driver with THVD80x0 Devices to Drive Low Impedance Loads

3.1 Overcoming Drive Strength Requirement with A Line Driver Amplifier

The standard approach to communication over powerlines using the THVD8000 or THVD8010 faces significant obstacles. The first obstacle is the lack of drive strength for loads below 375 Ω ; however, the solution to this problem is simple – the addition of a line driver amplifier such as the THS6222. The benefit of this implementation is that larger output voltages can be sustained with more current over lower impedance loads for which a traditional RS-485 driver is specified. The line driver must be able to operate at the modulation frequency chosen and be able to transmit valid data at the specified line to ground impedance of the system, which requires high linearity under heavy line loads. The device doesn't need to be rated for the AC mains voltage as a protection circuit, transformer, and high voltage capacitor all stand in between the mains voltage and the line driver. The addition of the line driver amplifier like the THS6222 or similar devices can increase the max load from 375 Ω down to between 1 and 5 Ω .

3.2 Modification to Typical System Signal Chain Path Through Integration of Line Driver

The addition of a line driver to the system is straight forward when using the THS6222 and the THVD8000. For all higher voltage interface systems, regardless if they are 110 V or 600 V, can be implemented in either configuration shown in [Figure 1-1](#) and [Figure 1-2](#). [Figure 3-1](#) and [Figure 3-2](#) show how to connect the signal pathways between the THVD8000 and the THS6222.

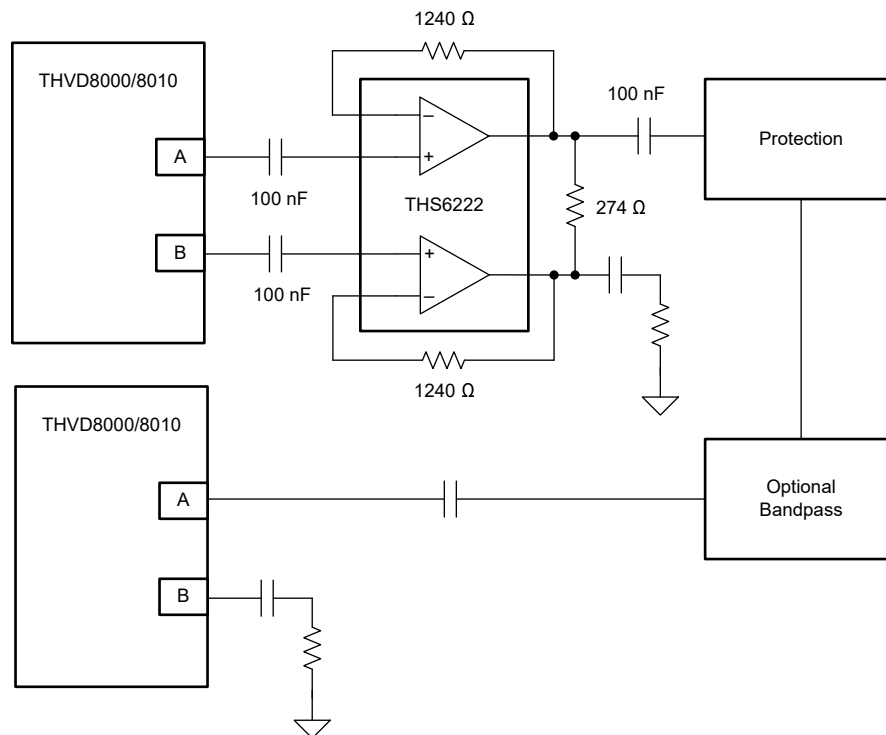

Figure 3-1. Integration of 2x THVD80x0 Devices with THS6222

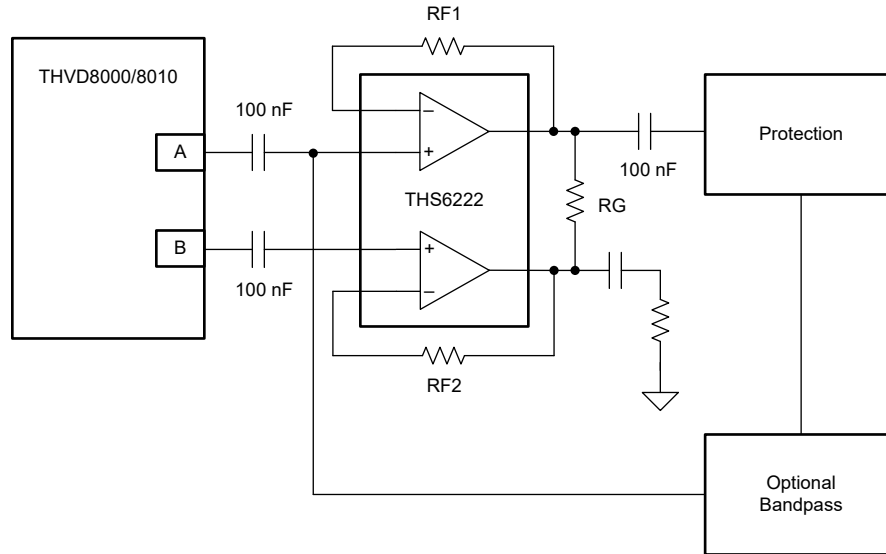

Figure 3-2. Integration of 1 THVD80x0 Device with THS6222

Both systems shown, operate in a similar way. For ease of design and less potential issues with integration the approach in [Figure 3-2](#) is best; however, it is possible to use [Figure 3-2](#) to achieve the same end goal with less THVD8000 Transceivers. Not shown, in the previous figures, is the integrated common mode buffer of the THS6222 which DC-couples the inputs to mid-supply of the device.

The differential gain (A_v) of the line should set $RF1 = RF2$; the differential gain is . The standard $A_v = 10$ ($RF1 = RF2 = 1240\Omega$; $RG = 274 \Omega$) is used when integrating the THVD8000 or THVD8010; as the output current drive is what's most necessary for this application so higher gains than the standard 10V/V are typically unneeded.

Signal chain connections aside, both the THVD8000/8010 and the THS6222 have different control modes that will be switched during operation. For the THVD8000/8010 this is going to be the MODE pin and for the THS6222 it is the BIAS1 and BIAS2 pins. The THVD8000/8010 mode pin lets the device switch between transmit and receive modes while the BIAS pins for the THS6222 set the bias current consumption – where higher bias currents means more power drawn and higher performance with respect to linearity for the operational amplifier. Please see [Table 3-1](#) on system configurations:

Table 3-1. System Configurations

System State	BIAS1 (Amp)	BIAS2 (Amp)	MODE (Transceiver)
Transmit Data (TX)	L	L	H
Receive Data (RX)	H	H	L

This mode table is accurate regardless if you are using the implementation from [Figure 3-1](#) or [Figure 3-2](#)

With the basis of adding a line driver discussed - the next step is to talk about how the driver and receive pathways connect with the protection and high voltage interface.

4 High Voltage Interface and Communication Interface Power Supply

4.1 Line Driver Output and Input RX signal Protection Circuit

When interfacing with higher voltage signals it is best to have robust protection to prevent damage to more sensitive components. The protection circuit connects directly to the line driver and receiving bandpass filter + THVD8000/THVD8010 so the protection circuit must ensure that no signal above the most sensitive components ratings is violated. In the case of the THS6222 and the THVD8000/THVD8010, the THVD80x0 devices are the most sensitive on the line. Luckily, The BOOSTXL-AFE031-DF1 board from TI comes with a perfect protection circuit on its PA output and input pathways for these types of applications and the same architecture can be utilized here. The architecture with diode part numbers shown below in [Figure 4-1](#).

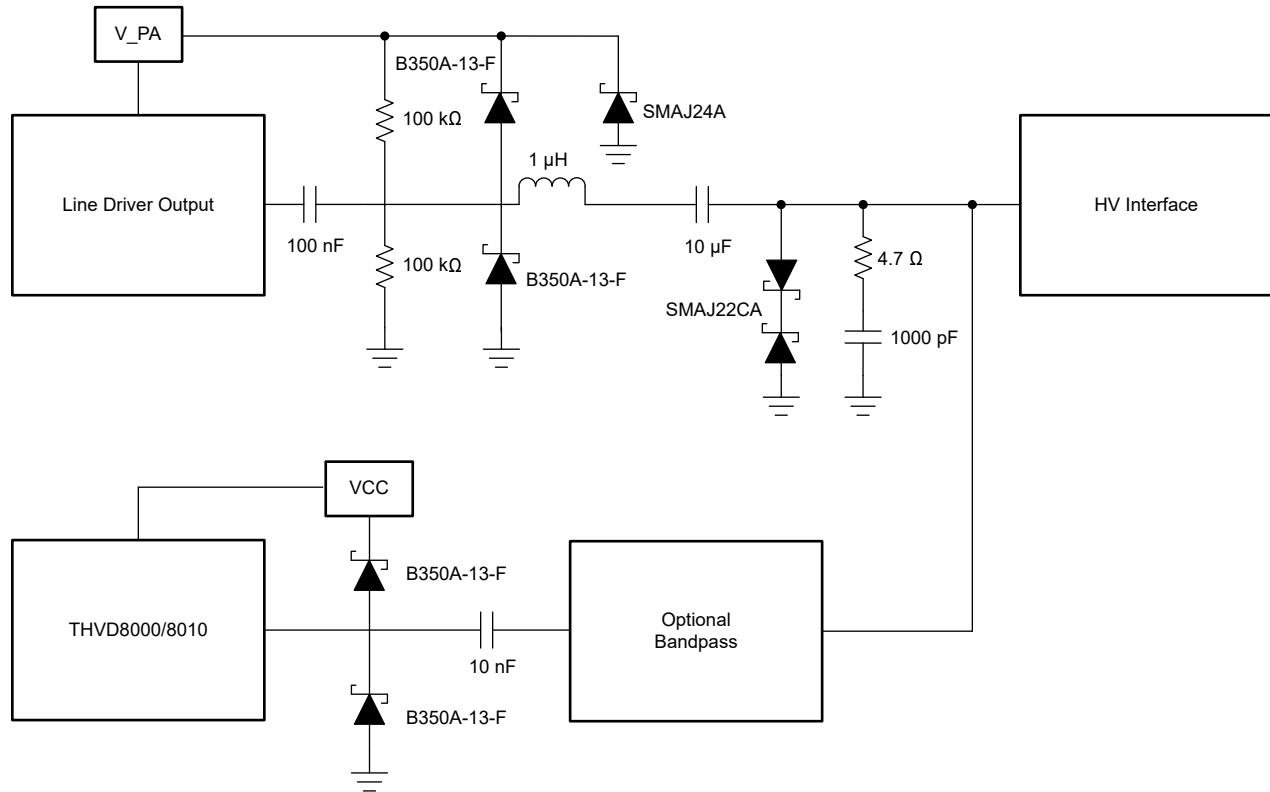

Figure 4-1. Protection Circuit for Line Driver and Transceivers

The power signal ideally should directly connect with the protection circuitry – however the robust protection shown above can help mitigate possible transient signals that could result in system damage without the above protection. There are three main protection concerns that are addressed with the above architecture. The first is that the line driver output is going to be clamped to the line driver’s power source (V_{PA}) in cases of overvoltage and it will be clamped to ground in cases of undervoltage. The second is very similar to the first in that the RX pathway is also protected – this is done by having the max clamp voltage set to VCC , the THVD8000/8010’s power supply, and the min clamping voltage set to ground. Finally, the third is to have an extra protection TVS diode right off the high voltage interface to add extra protection to both the TX and RX pathways.

Beyond the protection diodes there are the inclusion of LC components. $L1$ and $C1$ are a bandpass that should have the THVD8000/8010’s modulated signal within its passband the same can be said about $C3$ – however if the optional bandpass is included $C3$ will load that filter. The RC snubber (made of $R3$ and $C4$) are there to attenuated high frequency noise – the main concern to address is that the snubber shouldn’t stress the driver at the frequency of interest – which for this case would be the modulation frequency.

4.2 High-Voltage Interface

The next piece of the system is one of the simplest, yet one of the most important aspects of the system, that is the high voltage interface. For AC applications this interface is shown in Figure 4-2 and it is simply a transformer and high voltage capacitor.

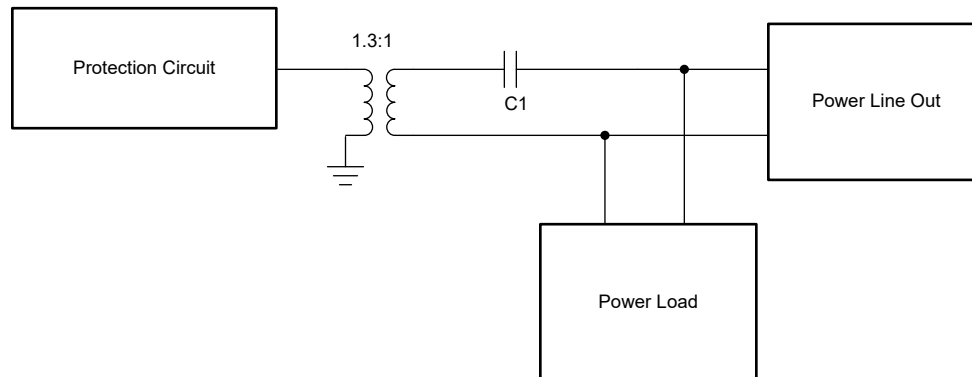

Figure 4-2. HV Interface for High Voltage/Low Impedance AC Power Lines

This circuit serves one main purpose – to act as a bandpass filter to allow the communication signal to be coupled onto the main line while preventing the low frequency AC signal from feeding back into the protection circuit. This becomes clearer when the equivalent transformer circuit is used. This is shown in Figure 4-3.

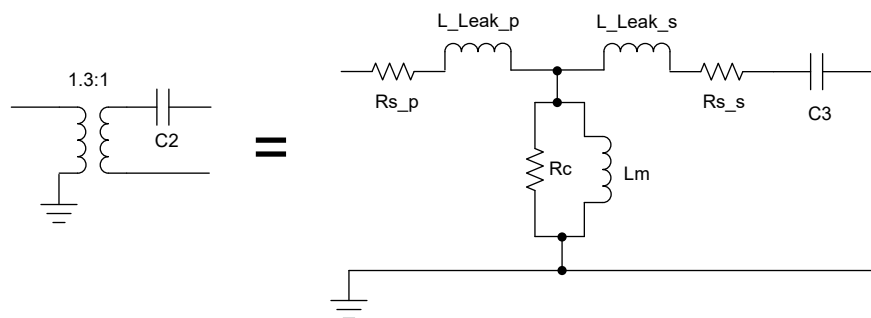

Figure 4-3. HV Interface Equivalent Circuit

The capacitor and transformer together create a bandpass filter. The goal of this filter is to filter out the AC mains frequency (~60Hz) while keeping the communication modulation frequency within the pass band. The parameters of the transformer can be found in the transformers datasheet where leakage inductance is $L_{leak_p} + L_{leak_s}$, core resistance is R_c (if not shown assume R_c to be open circuit), core inductance is L_m , the primary winding resistance is R_{s_p} , and the secondary winding is R_{s_s} . Please note that the above figure has “transformed” the equivalent circuit to remove the turns ratio – to convert secondary components to their “transformed” version, s, so that an accurate model is retained, divide the original impedance value by the turn’s ratio (Primary to Secondary) squared. For most transformer datasheets the only value you may have to transform is R_{s_s} which would be $R_{s_s}' = R_{s_s} / (\text{turn's ratio})^2$.

After the bandwidth has been sorted out the capacitor must be rated for high voltage applications as it will take the brunt of the incoming signal. For a 110 VAC too 220 VAC application a 1.5 kV rated capacitor was used.

If the end power line is not AC and is high voltage DC – the transformer is unnecessary and only the high voltage capacitor is needed as the capacitor will block the high DC voltage.

4.3 Receive Path Optional Bandpass

The optional bandpass filter on the RX path that is shown in [Figure 4-4](#) is used to help suppress any frequencies that are outside the modulated carrier frequency of the data signal. Since the HV interface does some initial filtering this is not necessary, but it helpful in further cleaning up the signal. The BOOSTXL-AFE031-DF1 also provide a good RX path architecture which can be utilized here. This is shown in [Figure 4-4](#)

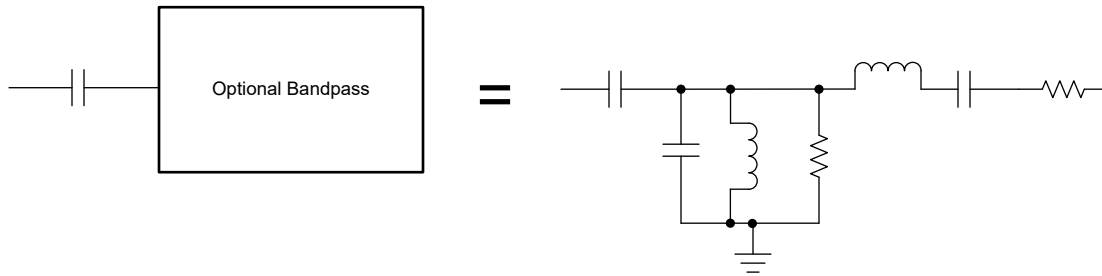

Figure 4-4. Bandpass Circuit Design

With a basic understanding of the signal path for the system – it is time to look at the system from top level including powering and operating the system.

5 System Level View and Relation to Higher Voltage Implementations

5.1 Powering the Powerline Communication System

One remaining challenge is presented with this type of circuit implementation – how to power it. There are two different power supplies used in this application:

1. The Line Driver and Protection Circuitry Source.
2. The THVD8000/THVD8010 + MCU/Related Devices VCC. Since this system is directly attached to a power line – the power should be sourced from here.

The first option is an offline converter which will take a rectified signal (AC) and step it down to the line driver voltage. The line driver power supply voltage is going to be larger than what the MCU/THVD8000/8010 can handle so another SMPS must be added to provide power for these objects as well. An optional LDO can also be used to get a smoother power signal for the MCU/THVD8000/THVD8010 devices. Some good devices to look at are the UCC28880 Offline Converter for the first stage of the power tree and then have that feed into a TPS62177 to generate the low VCC voltage for the THVD8000/THVD8010 and the MCU. The UCC28880 EVM also comes with a rectifier that can be used for AC applications. Check these device datasheets for instructions on how to set your voltages.

5.2 System Overview with Selected Test Results

With the system fully explained it is time to look at how all these parts mesh together as well as look at some test data from a couple different implementations of these designs. [Figure 5-1](#), [Figure 5-2](#), [Figure 5-3](#), and [Figure 5-4](#) show the schematics of the THVD8000 (TX/RX), line driver interface, protection/filtering/high voltage interface, and the power tree respectively.

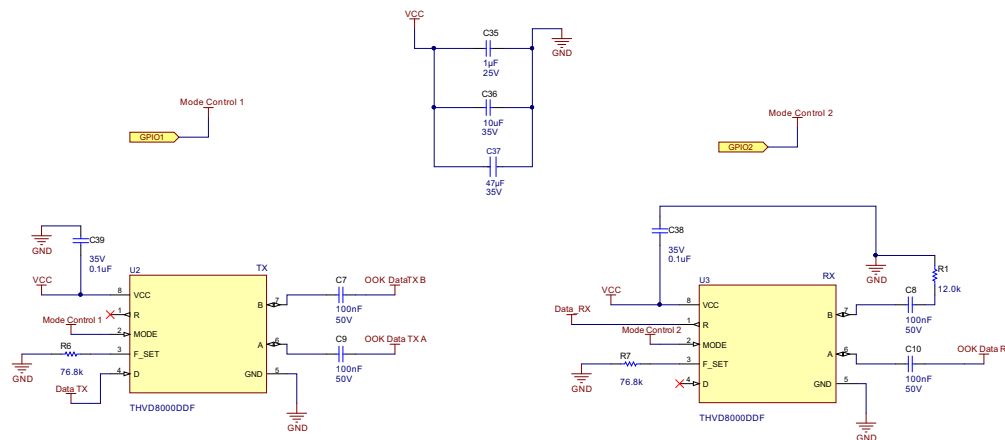

Figure 5-1. THVD8000 Schematic

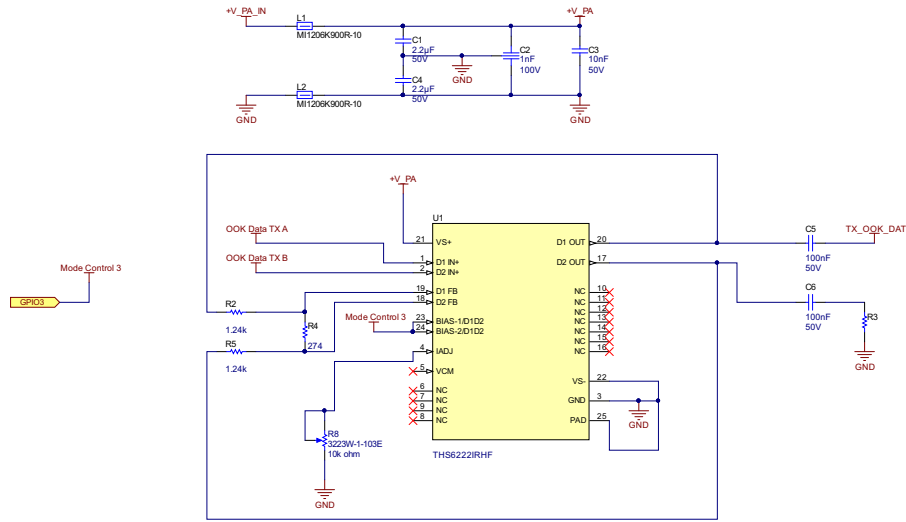

Figure 5-2. THS6222 Schematic

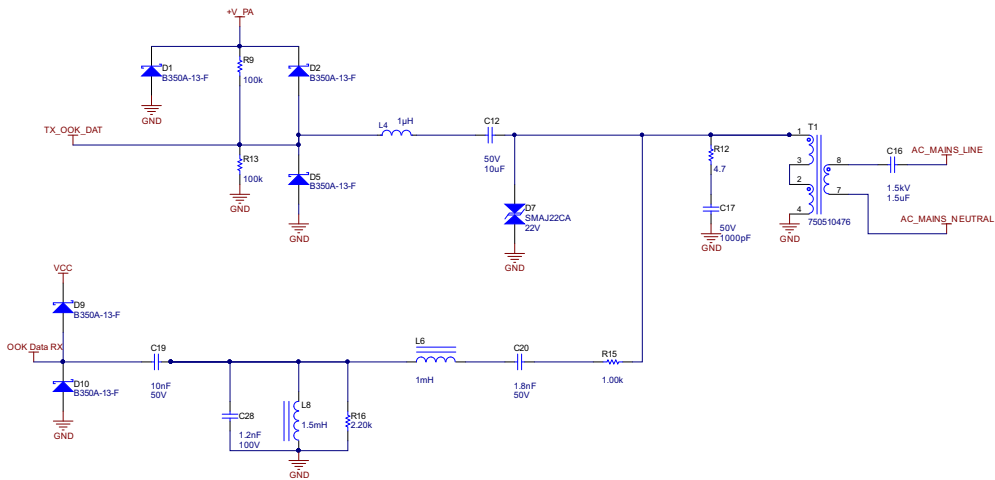

Figure 5-3. Protection/Bandpass/HV Interface Schematic

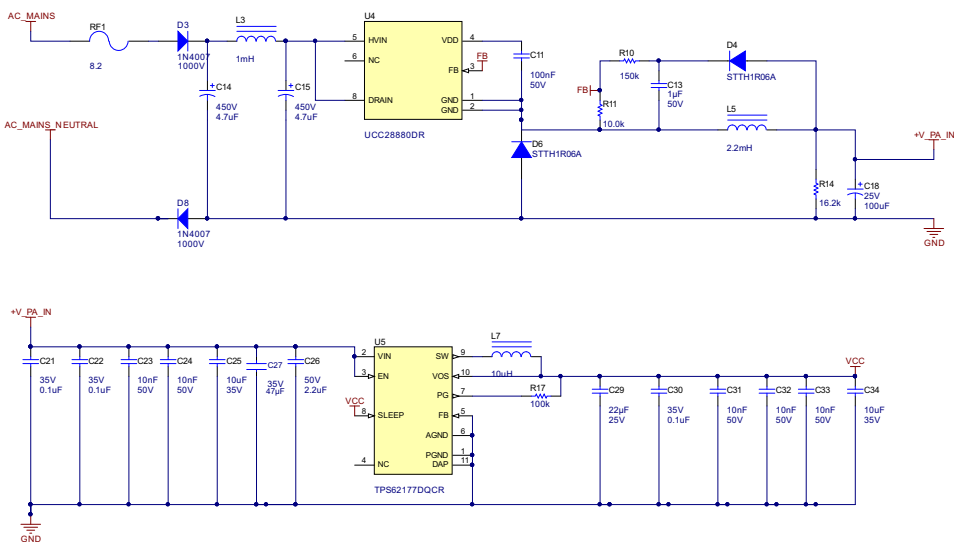

Figure 5-4. Power Tree Schematic

Table 5-1. High AC Voltage Interface Components

Component PN#	Comment
750510476	Werth Elektronik transformer
C4AQSBU4150A1XJ	1.5uF 1.5kV Capacitor KEMET

This application uses a data rate of 2KHz, 110VAC line, modulation frequency of 125 KHz, a 16 V power supply for the THS6222 (± 8 V), and a 3.3 V power supply for MCU and THVD8000. Test results are shown in [Figure 5-5](#) through [Figure 5-9](#) where TX and RX are the input/output of the THVD8000 respectively.

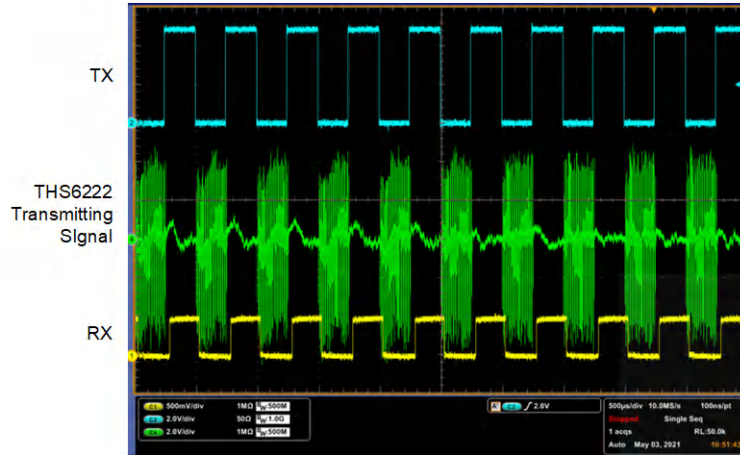

Figure 5-5. THVD8000 RX and TX signals; THS6222 Transmitting Signals

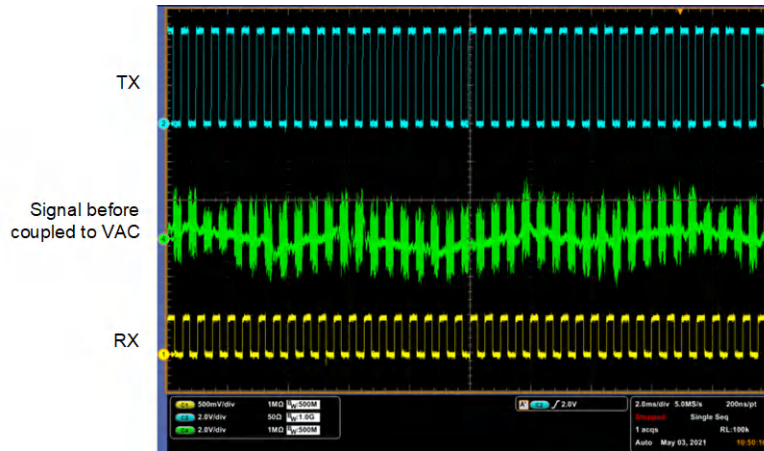

Figure 5-6. THVD8000 RX and TX signals; THS6222 Transmitting Signals - Zoomed Out

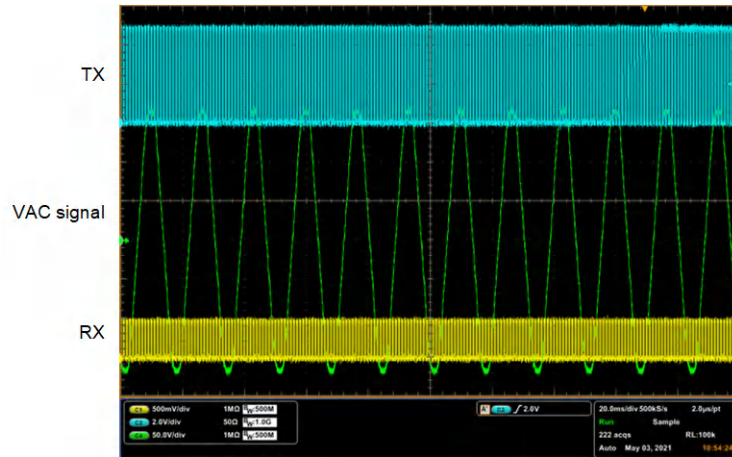

Figure 5-7. TX/RX data Overlaid on VAC Signal

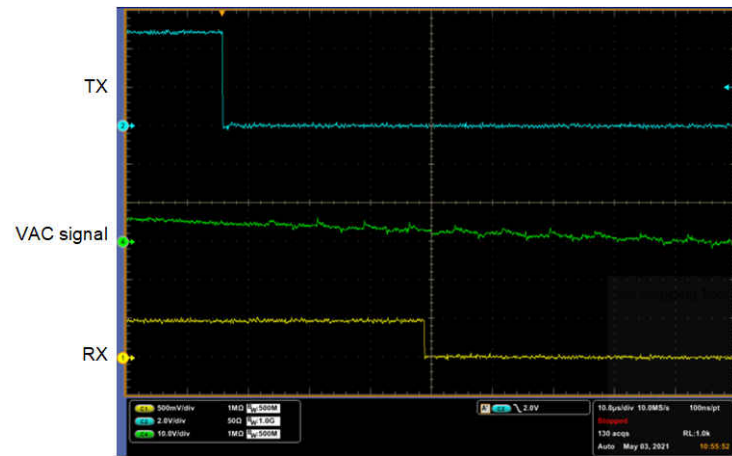

Figure 5-8. TX/RX data Overlaid on VAC Signal Zoomed In

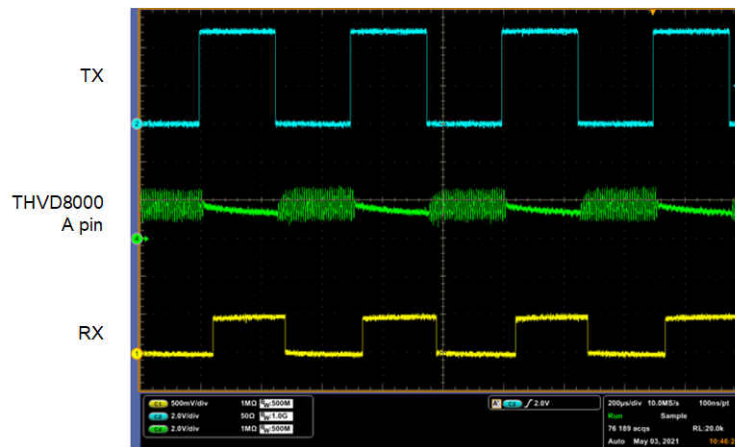

Figure 5-9. THVD8000 RX Signal on "A" Pin

5.3 Changes to Design for Higher Voltage AC or DC Applications

As previously mentioned there are some changes for higher voltage systems and or DC systems. For higher voltage AC systems, the main concern is to pick the HV interface that will prevent most of the VAC signal from coupling into the protection circuit. The other components mainly change based on modulation frequency which is AC Mains voltage independent. The transformer used for this design is rated to 400V on the primary as its working voltage – if your application is higher than 400 V a different transformer might need to be used.

For DC applications the transformer is unnecessary and can be removed as the high voltage capacitor will block the DC voltage and extra filter is not required.

6 Summary

The THVD8000 and THVD8010 are excellent devices when trying to communicate over a power line. Lower voltage systems (< ~30 V) with line to ground impedance's of 375 Ω benefit from the standard approach outlined in both the THVD8000 and THVD8010 data sheets as well as the THVD8000 design guide. Higher-voltage systems with line to ground impedance's of less than 375 Ω can benefit from the implementations detailed in this application note. To integrate the THVD8000/THVD8010 into a higher voltage and/or lower impedance systems modifications to the standard approach must be made. By utilizing a line driver such as the THS6222 in addition to the THVD8000 and THVD8010 to transmit RS-485 data; lines with less than 375 Ω to ground can be used as a transmission medium. With the addition of a protection circuit with a robust high-voltage interface not only can lines with less than 375 Ω be driven, but the high voltage signal pathway is isolated away from the communication circuit allowing for communication over the powerlines of any voltage if the interface can block and or filter out the high voltage signal. The THVD8000 and THVD8010 devices are excellent parts for transmitting RS-485 data over power lines and with a few modifications can be expanded to fit in most power line communication-based applications.

7 References

- Texas Instruments, [BOOSTXL-AFE031-DF1](#) user's guide.
- Texas Instruments, [THS6222 8 V to 32 V, Differential HPLC Line Driver with Common-Mode Buffer](#) data sheet.
- Texas Instruments, [THS6222RHF Evaluation Module](#) user's guide.
- Texas Instruments, [THVD8000 Design Guide](#) application note.
- Texas Instruments, [THVD8000 EVM User's Guide](#) user's guide.
- Texas Instruments, [THVD8000 RS-485 Transceiver with OOK Modulation for Power Line Communication](#) data sheet.
- Texas Instruments, [THVD8010 RS-485 Transceiver with OOK Modulation for Power Line Communication](#) data sheet.
- Texas Instruments, [TPS6217x 28-V, 0.5-A Step-Down Converter With Sleep Mode](#) data sheet.
- Texas Instruments, [UCC28880 700-V, 100-mA Low Quiescent Current Off-Line Converter](#) data sheet.
- Texas Instruments, [Using the UCC28880EVM-616](#) user's guide.

IMPORTANT NOTICE AND DISCLAIMER

TI PROVIDES TECHNICAL AND RELIABILITY DATA (INCLUDING DATA SHEETS), DESIGN RESOURCES (INCLUDING REFERENCE DESIGNS), APPLICATION OR OTHER DESIGN ADVICE, WEB TOOLS, SAFETY INFORMATION, AND OTHER RESOURCES "AS IS" AND WITH ALL FAULTS, AND DISCLAIMS ALL WARRANTIES, EXPRESS AND IMPLIED, INCLUDING WITHOUT LIMITATION ANY IMPLIED WARRANTIES OF MERCHANTABILITY, FITNESS FOR A PARTICULAR PURPOSE OR NON-INFRINGEMENT OF THIRD PARTY INTELLECTUAL PROPERTY RIGHTS.

These resources are intended for skilled developers designing with TI products. You are solely responsible for (1) selecting the appropriate TI products for your application, (2) designing, validating and testing your application, and (3) ensuring your application meets applicable standards, and any other safety, security, regulatory or other requirements.

These resources are subject to change without notice. TI grants you permission to use these resources only for development of an application that uses the TI products described in the resource. Other reproduction and display of these resources is prohibited. No license is granted to any other TI intellectual property right or to any third party intellectual property right. TI disclaims responsibility for, and you will fully indemnify TI and its representatives against, any claims, damages, costs, losses, and liabilities arising out of your use of these resources.

TI's products are provided subject to [TI's Terms of Sale](#) or other applicable terms available either on ti.com or provided in conjunction with such TI products. TI's provision of these resources does not expand or otherwise alter TI's applicable warranties or warranty disclaimers for TI products.

TI objects to and rejects any additional or different terms you may have proposed.

Mailing Address: Texas Instruments, Post Office Box 655303, Dallas, Texas 75265
Copyright © 2022, Texas Instruments Incorporated