

Powering the TPS546D24A Device Family From a Single 3.3-V Input Power Supply

ABSTRACT

The 3.3-V, 5-V, and 12-V rails have been the most popular voltages for microelectronic circuits for decades. Years ago, many components and integrated circuits used a 12-V or 5-V supply, and when the process technology shrunk, the required voltage dropped to 3.3 V. Today, integrated circuits use a much wider variety of voltages, and many are far below 1 V. Interestingly, the 12-V, 5-V and 3.3-V rails still remain despite many process technology reductions. For example, most modern computer power supplies follow the ATX (Advanced Technology Extended) motherboard convention and provide +3.3 V, +5 V, +12 V, and –12 V for the use of the circuit board. Many power supplies still provide these voltages and rely on other DC/DC converters to support the ever-growing number of point-of-load voltages. There are advantages and disadvantages to using a particular input voltage rail for point-of-load conversion, and explaining these are beyond the scope of this document. However, this application note will explore several techniques using an available 3.3-V rail when the internal circuitry of the DC/DC converter does not support 3.3-V operation. The TPS546D24A, a 40-A step-down converter with PMBus™ and telemetry will be used as an example, but the techniques can be useful for other DC/DC converters that provide split-rail support.

Contents

1	Split-Rail Support	2
2	3.3-V Operation with a Discrete Charge-pump	2
3	3.3-V Operation with a Charge-pump Integrated Circuit	3
4	3.3-V Operation with a Boost Converter Power Module	4
5	Summary	5
6	Resources	5

List of Figures

1	TPS546D24A Demonstrating Split-rail Support with AVIN and PVIN Pins	2
2	Discrete Charge-pump Circuit Driven From TPS546D24A SYNC Pin	3
3	140-mA, 5-V TPS60150 Charge-pump Circuit	4
4	140-mA, 5-V TPS60150 Charge-pump Layout Example	4
5	TPS81256 550-mA, 5-V Power Module Circuit	5
6	TPS81256 550-mA, 5-V Power Module Layout Example	5

List of Tables

1	Discrete Components for Charge-pump Circuit	3
2	Comparison of 3.3-V input to 5-V Output Solutions	5

Trademarks

PMBus is a trademark of SMIF, Inc.
All other trademarks are the property of their respective owners.

1 Split-Rail Support

Interestingly, the term ‘split-rail’ has been used historically to describe a decorative fence made out of timber logs, usually split lengthwise into rails. In power supply terms, it is used to describe multiple input voltage pins. [Figure 1](#) shows the TPS546D24A providing split-rail support with AVIN and PVIN pins. The AVIN pin supplies power to the controller, and the PVIN pin supplies power to the power stage or power MOSFETs. The TPS546D24A PVIN pin allows 2.95-V to 16-V input for conversion, and the AVIN pin allows 2.95-V to 18-V input for operation, and 4-V to 18-V for switching. Note that the VDD5 pin is the output of the 5-V internal low drop out (LDO) regulator, which powers the driver stage of the controller. One advantage of split-rail operation, when using a higher PVIN voltage such as 12 V, is to over-drive the 5 V LDO regulator with an external 5 V supply to improve efficiency and reduce power dissipation. In this case, the LDO power loss is avoided. Another advantage is the ability to use a 3.3 V rail for PVIN when other rails are not available or to increase the duty cycle and switch at a higher frequency to reduce the size of the output inductor and capacitors.

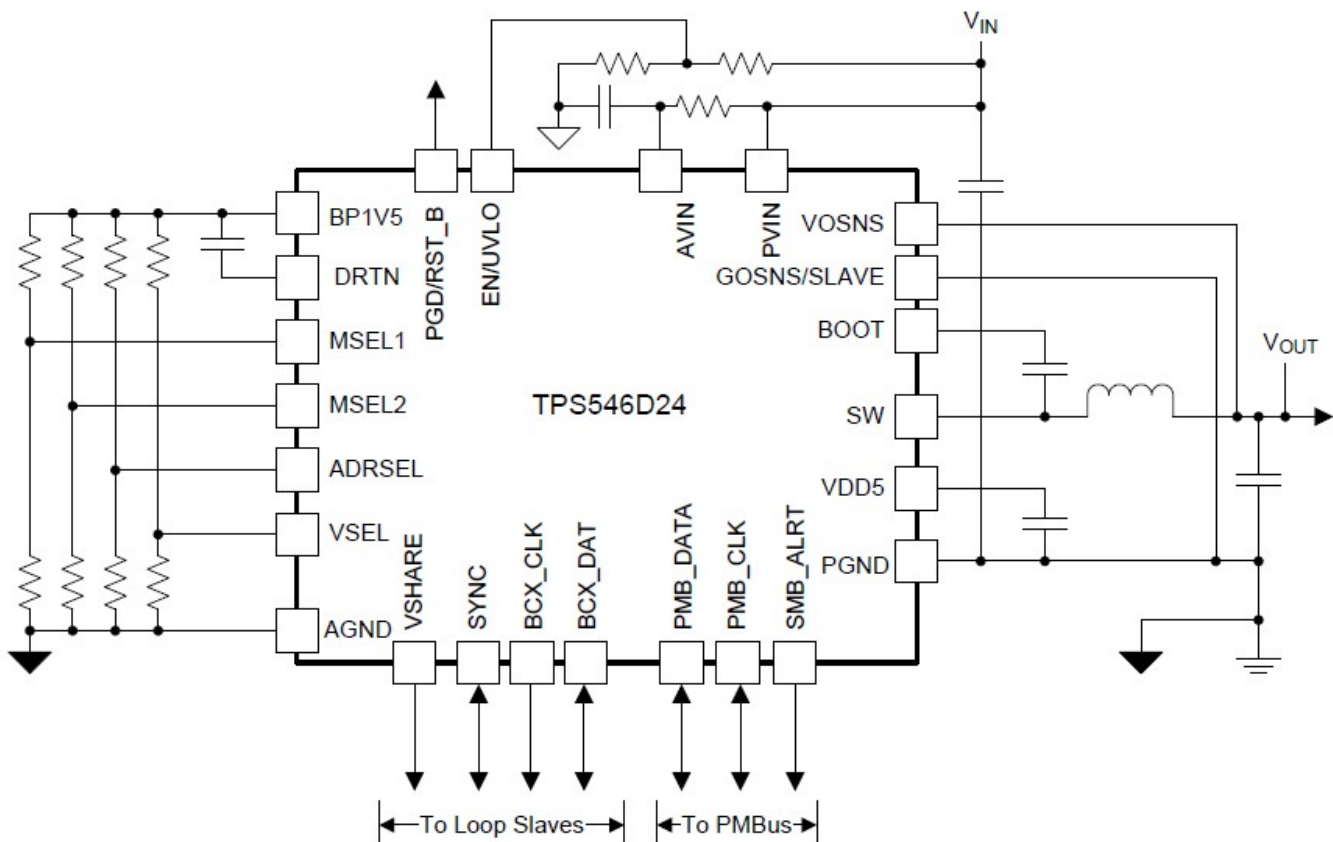

Figure 1. TPS546D24A Demonstrating Split-rail Support with AVIN and PVIN Pins

2 3.3-V Operation with a Discrete Charge-pump

The required bias current of a DC/DC converter depends on its operating frequency and characteristics of the power MOSFETs. The discrete charge-pump must be able to provide the required current. According to [Equation 1](#), the TPS546D24A draws approximately 70.5 mA from the AVIN supply while switching at 1.5 MHz. An external circuit shown in [Figure 2](#) can be easily added to implement a discrete voltage-doubling charge-pump, driven by the SYNC pin of the TPS546D24A. When the 3.3-V input rail ramps, the controller becomes active at 2.95 V, begins the configuration sequence, and loads the external resistor

pin-strapping values. With the pin-strap option is selected for SYNC_OUT, the SYNC pin starts switching while AVIN completes the ramp up to 3.3 V. The SYNC pin drives the base of the 0.22-μF capacitors 3.3 V at a 50% duty cycle, which charges up the 2.2-μF capacitor connected to AVIN, boosting the voltage higher than 4 V. Then, the device begins switch-mode conversion. In other words, when AVIN is greater than 2.95 V and the SYNC pin starts switching, the charge-pump boosts the AVIN pin above 4 V and the TPS546D24A begins switching the power MOSFETs for voltage conversion. If the 3.3 V rail has a wide tolerance or if there is any risk of overshoot on the input voltage rail, it is recommended to place a Zener diode to clamp the voltage applied to the AVIN pin. The Diodes Incorporated SD103ATW-7-F is suggested for the Schottky diodes, and integrates all three diodes in a small SOT-363 package. The routing of the diodes in one package is very straight forward. The SI869DH is suggested for the dual MOSFET and is available in the same SOT-363 package as the diode array, which allows a small compact solution. The recommended 10-μF input capacitor is a 10-V X5R rating in a 0805 package. The flying capacitor suggestion is a 220 nF with a 10-V rating in a 0402 package. [Table 1](#) summarizes the bill of materials for the discrete charge-pump circuit.

$$I_{AVIN} = 18mA + (0.035mA \times \text{Switching Frequency (kHz)}) \tag{1}$$

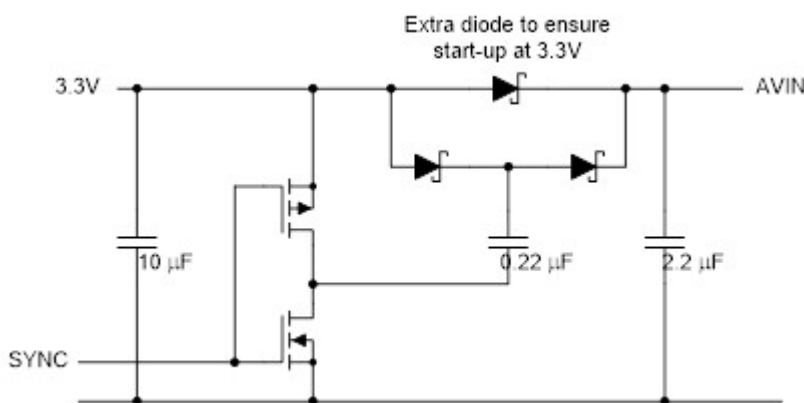

Figure 2. Discrete Charge-pump Circuit Driven From TPS546D24A SYNC Pin

Table 1. Discrete Components for Charge-pump Circuit

COMPONENT	PART/TYPE	PACKAGE
Dual MOSFET	SI869DH	SOT-363
Triple Schottky Diodes	SD103ATW-7-F	SOT-363
Input Capacitor	10 μF, 10 V, X5R	0805
Flying Capacitor	220 nF, 10 V	0402

3 3.3-V Operation with a Charge-pump Integrated Circuit

A simple 6-pin charge-pump integrated circuit shown in [Figure 3](#) can also be used, especially when the SYNC pin function of the TPS546D24A is needed for another purpose. The 140-mA TPS60150 has several advantages, such as its regulation accuracy, integrated protection, and small size while avoiding the use of an inductor. Only four components are needed as shown in [Figure 3](#). The circuit occupies about 15 in² of board space. The IC is 2-mm x 2-mm, each capacitor is in a 0603 package, and several vias are used that occupy a small space. The output voltage is fixed at 5 V to eliminate external resistors. The TPS60150 starts up in less than 150 μs and does not interfere with the operation of the TPS546D24A configuration sequence. Additionally, the charge-pump begins operation when the AVIN input is 2.7 V, which is lower than the 2.95 V start-up voltage of the TPS546D24 AVIN pin.

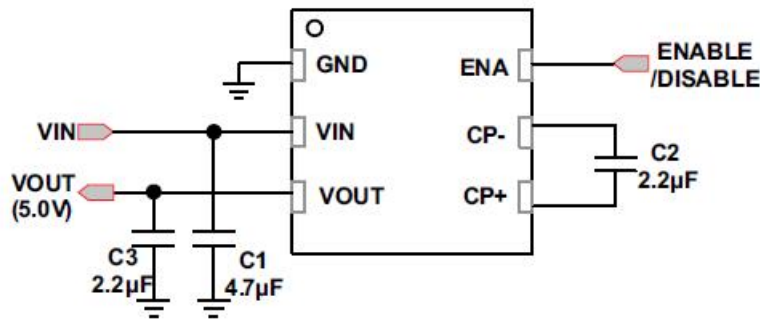
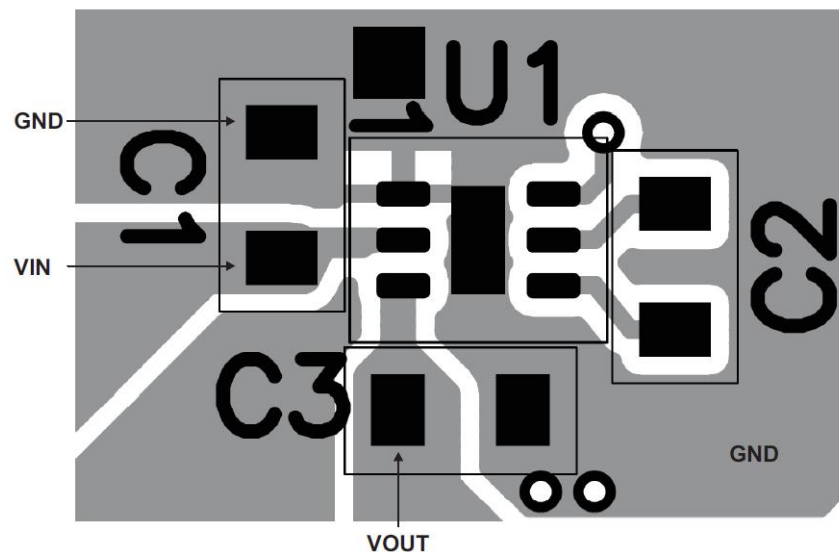
Figure 3. 140-mA, 5-V TPS60150 Charge-pump Circuit

Figure 4. 140-mA, 5-V TPS60150 Charge-pump Layout Example

4 3.3-V Operation with a Boost Converter Power Module

If the TPS546D24 needs to operate at a higher frequency, an inductive boost solution can be required to supply more current to AVIN. The TPS81256 is a 5-V output boost module as shown in [Figure 5](#) and integrates the inductor and input and output capacitors in a small 2.6-mm x 2.9-mm x 1-mm package. Since the inductor is integrated within the package, the total solution is smaller than the discrete charge-pump and the charge-pump integrated circuit. The current capability of the module is 550 mA with a 3.3-V input and a 5-V output. According to [Equation 1](#), the TPS81256 provides more than enough current to the TPS546D24 AVIN pin when the converter is operating at 1.5-MHz. The start-up is in 400 µs from active enable to turn on. The start-up voltage is 2.5-V, which does not interfere with the TPS546D24A configuration sequence. [Figure 6](#) shows the small size of the integrated power module and all of the included components within the dotted line of [Figure 5](#).

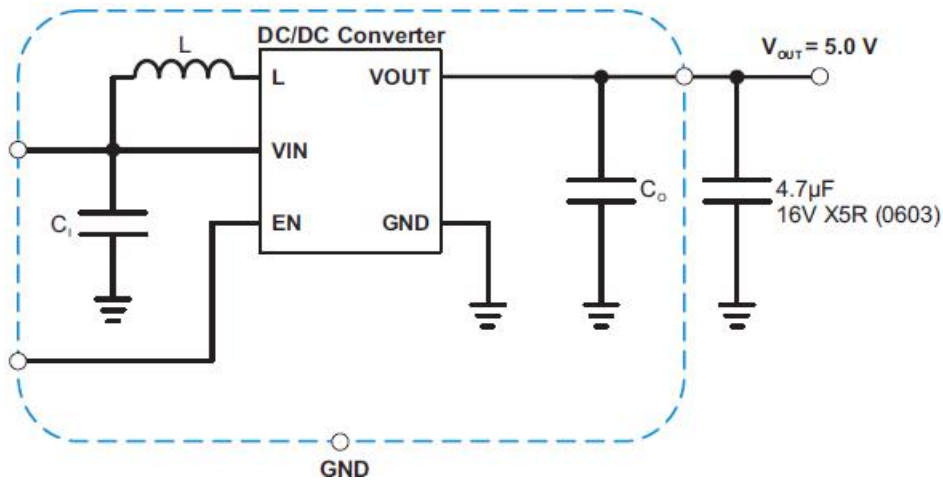

Figure 5. TPS81256 550-mA, 5-V Power Module Circuit

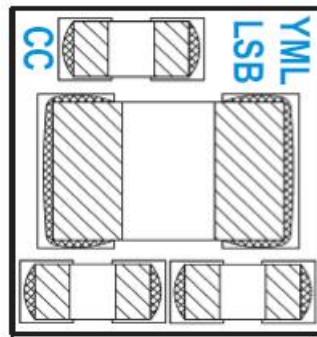

Figure 6. TPS81256 550-mA, 5-V Power Module Layout Example

5 Summary

The 3.3-V rail has not gone away. Certain applications like optical modules or X-haul transport equipment can use a 3.3-V rail and require a point-of-load power management solution for high-current processors. In some cases, the 5-V and 12-V rails of an ATX power supply can be exhausted without remaining current capacity. This document reviewed several solutions to provide a 5 V bias to the split-rail TPS546D24A from a simple discrete solution to an integrated power module. The key trade-offs of each solution are highlighted in [Table 2](#).

Table 2. Comparison of 3.3-V input to 5-V Output Solutions

5 V SOURCE FROM 3.3 V	SOLUTION SIZE	SOLUTION COST AT 1 Ku
Boost module – TPS81256	9 mm ²	\$1.00
Charge-pump IC – TPS60150	15 mm ²	\$0.63
Discrete charge- pump	20 mm ²	\$0.40

6 Resources

- Texas Instruments, [When and How to Supply an External Bias for Buck Controllers – Part 3 Blog](#)
- [TPS60150 Product Page](#)
- [TPS81256 Product Page](#)
- [TPS546D24A Product Page](#)

Revision History

NOTE: Page numbers for previous revisions may differ from page numbers in the current version.

Changes from Original (December 2019) to A Revision	Page
• Changed current and switching values of TPS546D24A device in Section 2	2
• Changed equation.	3

IMPORTANT NOTICE AND DISCLAIMER

TI PROVIDES TECHNICAL AND RELIABILITY DATA (INCLUDING DATA SHEETS), DESIGN RESOURCES (INCLUDING REFERENCE DESIGNS), APPLICATION OR OTHER DESIGN ADVICE, WEB TOOLS, SAFETY INFORMATION, AND OTHER RESOURCES "AS IS" AND WITH ALL FAULTS, AND DISCLAIMS ALL WARRANTIES, EXPRESS AND IMPLIED, INCLUDING WITHOUT LIMITATION ANY IMPLIED WARRANTIES OF MERCHANTABILITY, FITNESS FOR A PARTICULAR PURPOSE OR NON-INFRINGEMENT OF THIRD PARTY INTELLECTUAL PROPERTY RIGHTS.

These resources are intended for skilled developers designing with TI products. You are solely responsible for (1) selecting the appropriate TI products for your application, (2) designing, validating and testing your application, and (3) ensuring your application meets applicable standards, and any other safety, security, regulatory or other requirements.

These resources are subject to change without notice. TI grants you permission to use these resources only for development of an application that uses the TI products described in the resource. Other reproduction and display of these resources is prohibited. No license is granted to any other TI intellectual property right or to any third party intellectual property right. TI disclaims responsibility for, and you will fully indemnify TI and its representatives against, any claims, damages, costs, losses, and liabilities arising out of your use of these resources.

TI's products are provided subject to [TI's Terms of Sale](#) or other applicable terms available either on ti.com or provided in conjunction with such TI products. TI's provision of these resources does not expand or otherwise alter TI's applicable warranties or warranty disclaimers for TI products.

TI objects to and rejects any additional or different terms you may have proposed.

Mailing Address: Texas Instruments, Post Office Box 655303, Dallas, Texas 75265
Copyright © 2022, Texas Instruments Incorporated