

Laser and Motor Drives

This document is provided as a supplement to the [DRV8811](#) datasheet. It details the hardware implementation of the DRV8811 customer evaluation module (EVM).

Contents

1	Introduction	3
	1.1 Block Diagram	3
	1.2 Power Connectors	3
	1.3 Test Stakes	3
	1.4 Jumpers	4
	1.5 Motor Outputs	4
2	Installing Drivers And Software	4
	2.1 Installing the FTDI USB Driver	4
	2.2 GUI Software Installation	4
	2.3 Running the Windows Application Software	15
3	Windows Application	15
	3.1 Menu	17
	3.2 DRV8811 GPIO Control Signals	18
	3.3 Updating DAC Output for Current Control (VREF/DECAY)	19
	3.4 Updating DAC Output for Decay Control (DECAY)	19
	3.5 Operating the Stepper Motor	20

List of Figures

1	VREF SELECT Jumper	4
2	DECAY SELECT Jumper	4
3	Setup_DRV8811_EVM.exe	5
4	Installation Initialization	6
5	License Agreement	6
6	NI License Agreement	7
7	Installation Directory Screen	7
8	Component Selection	8
9	Configure Proxy	8
10	Ready to Install	9
11	Downloading RTE	9
12	LabVIEW RTE Self Extraction	10
13	LabVIEW RTE Installation Initialization	10
14	Installation of LabVIEW RTE in Progress	11
15	FTDI Installation Initialization	12
16	Driver Installation Wizard	12
17	License Agreement for FTDI Driver	13
18	Driver Installation Completion	14
19	Installation Complete	14
20	Readme Window	15
21	DRV8811EVM-001_R1p0.exe Main Screen	16

22	File Menu	17
23	Debug Menu	17
24	Schematic	17
25	Help Menu	18
26	About Page	18
27	Signals Frame	19
28	Curent Control Frame	19
29	Current Control Frame.....	20
30	Step Rate	20
31	Speed Control Frame.....	21
32	Step Control Frame	21

Trademarks

All trademarks are the property of their respective owners.

1 Introduction

The DRV8811EVM-001 customer EVM is the complete solution to evaluating the DRV8811 microstepping bipolar stepper driver. It houses a USB link to provide easy control from a PC computer, an MSP430 microcontroller that interprets serial commands from the PC and generates control signals to the driver device, and the DRV8811 device with access to all signals for a complete evaluation.

1.1 Block Diagram

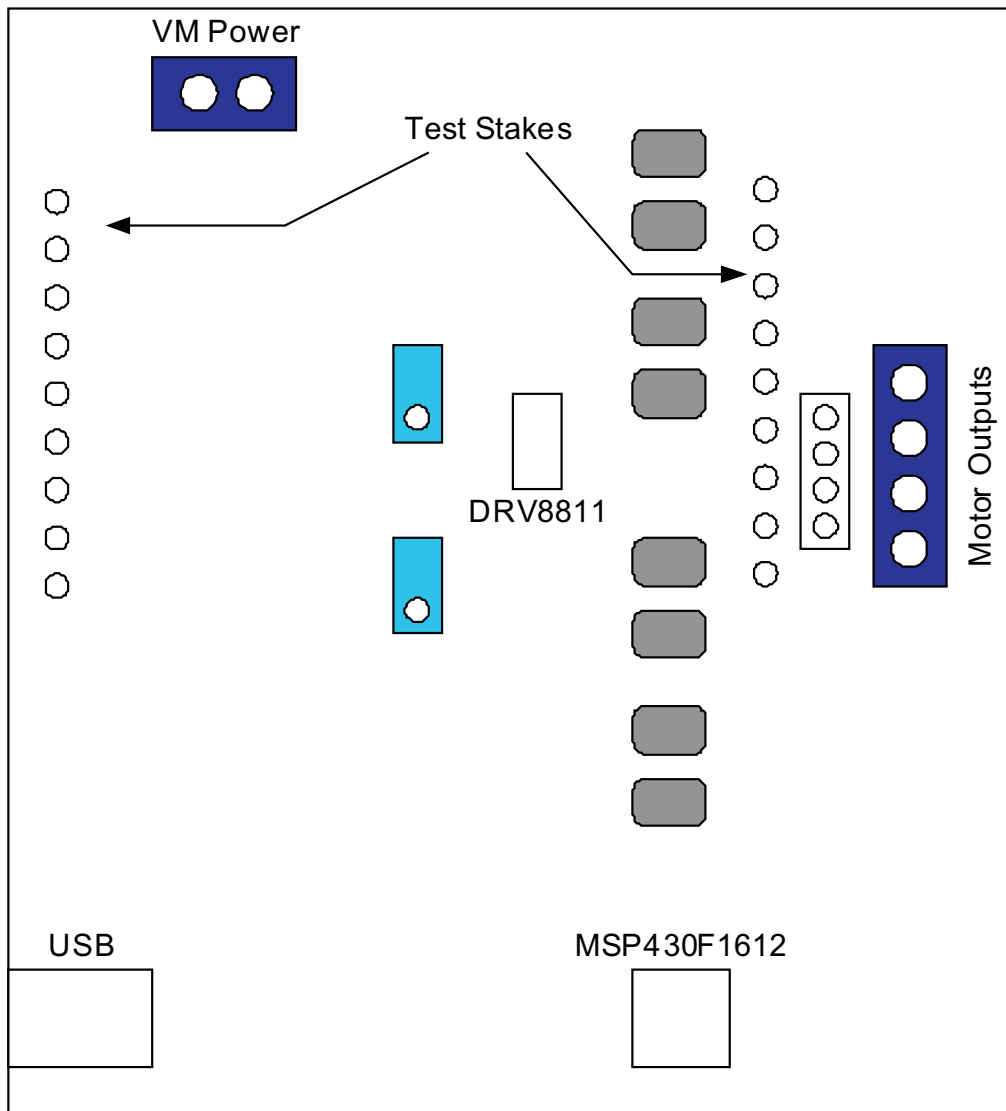

1.2 Power Connectors

The DRV8811 customer EVM uses a combination of terminal blocks and test clips for the application/monitoring of power. The only power rail the user must supply is VM for the device's power stage. VDD for logic levels is internally generated from the USB connection.

The user must apply VM according to datasheet recommended parameters.

1.3 Test Stakes

Every pin on the device has been brought out to a test stake. A label on the silkscreen identifies each signal.

1.4 Jumpers

Three pin jumpers can be configured independently from the other two or three pin jumpers. However, two pin jumpers must either be closed or open. Two pin jumpers (JP2 to JP5) connect the diodes to the motor outputs and are used under asynchronous rectification (SR = LO).

1.4.1 VREF SELECT (JP1) Jumper

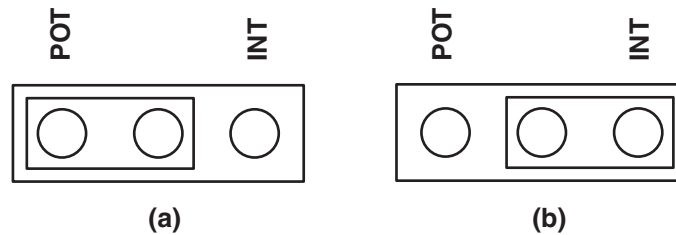

Figure 1. VREF SELECT Jumper

To configure the VREF SELECT jumper: [Figure 1 \(a\)](#) selects an analog voltage derived from VDD through a voltage divider implemented as a potentiometer R4. [Figure 1 \(b\)](#) selects an analog voltage derived from the MSP430's digital to analog converter channel 0 (DAC0).

1.4.2 DECAY SELECT (JP6) Jumper

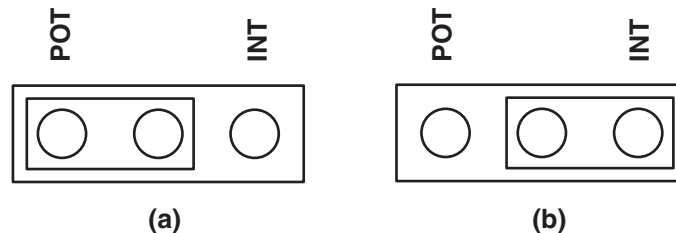

Figure 2. DECAY SELECT Jumper

To configure the DECAY SELECT jumper: [Figure 2 \(a\)](#) selects an analog voltage derived from VDD through a voltage divider implemented as a potentiometer R6. [Figure 2 \(b\)](#) selects an analog voltage derived from the MSP430's digital to analog converter channel 1 (DAC1).

1.5 Motor Outputs

There are three ways of connecting the bipolar stepper motor into the DRV8811 EVM: four pin header (J2), four position terminal block (J3) or test clips. Each connection style offers identical connectivity to the device's output terminals. It is recommended, however, to use the header or terminal block, as the test stakes traces are of low current handling capability.

2 Installing Drivers And Software

2.1 Installing the FTDI USB Driver

Instructions on how to install the FTDI USB driver on a Windows based computer are detailed in the "USB_Drivers_Install_Readme.pdf" file supplied with the CD inside the USB_Driver folder.

2.2 GUI Software Installation

The following section explains the location of files and the procedure for installing the software correctly.

NOTE: Ensure that no USB connections are made to the EVM until the installation is completed. The installer will also install LabVIEW RTE 2014 and FTDI Driver, along with the GUI.

2.2.1 System Requirements

- Supported OS – Windows 7 (32 Bit, 64 Bit). The window text size should be Smaller-100% (Default)
- Recommended RAM - 4 GB or higher
- Recommended CPU Operating Speed – 3.3 GHz or higher

2.2.2 Installation Procedure

The following procedure helps you install the DRV8811 GUI

1. Double click on the **Setup_DRV8811_EVM.exe** as shown in [Figure 3](#).

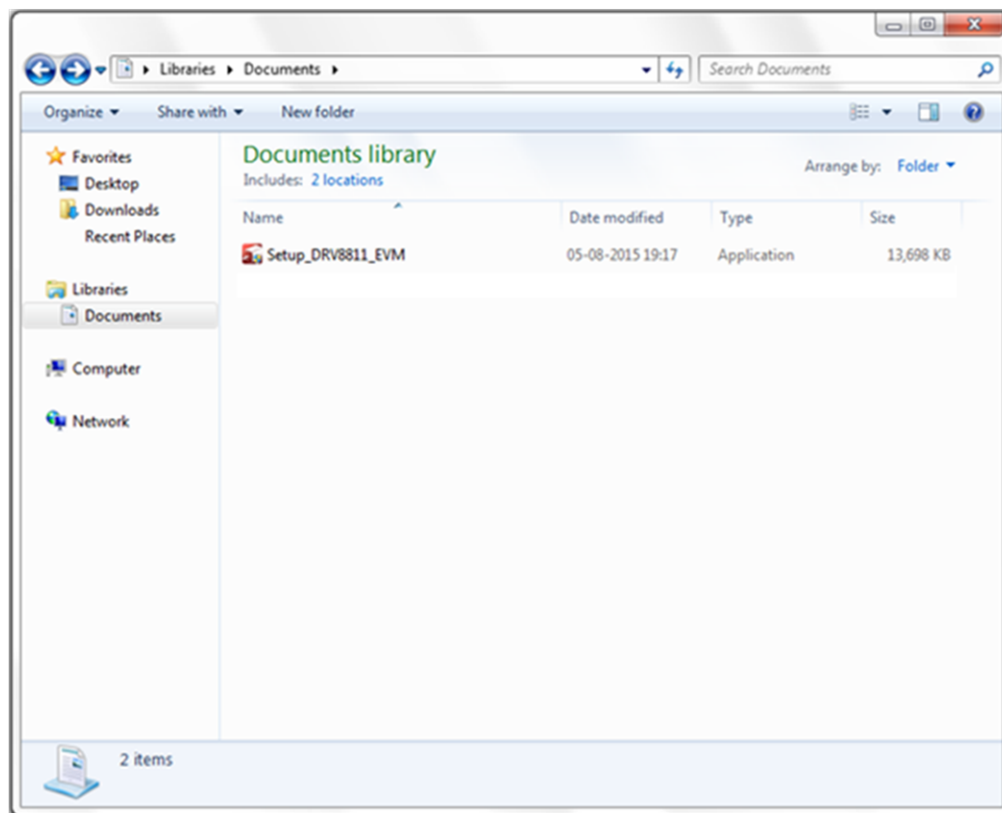

Figure 3. Setup_DRV8811_EVM.exe

2. The screen shown in [Figure 4](#) appears, indicating installer initialization. Click the **Next** button.

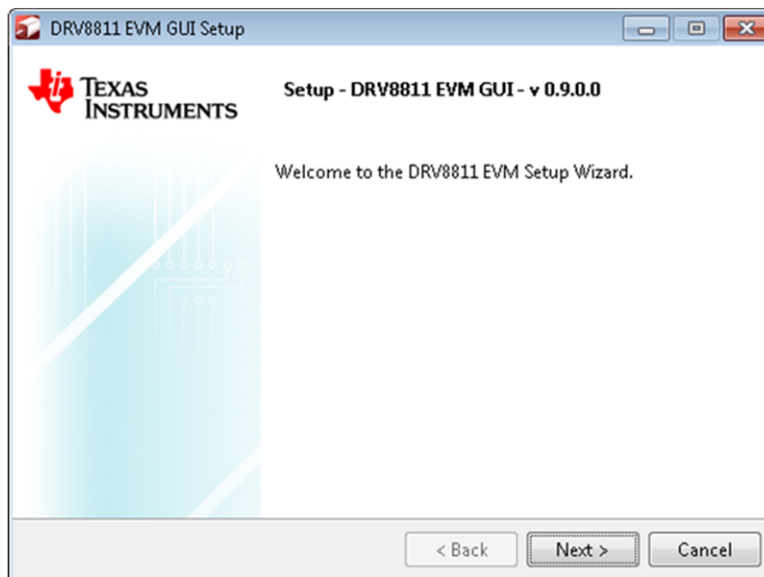

Figure 4. Installation Initialization

3. In the newly open installation pop-up window, click **Next**. The license agreement will be displayed. Please, read through it carefully and enable the "I Accept the Agreement" radio button and press **Next**.

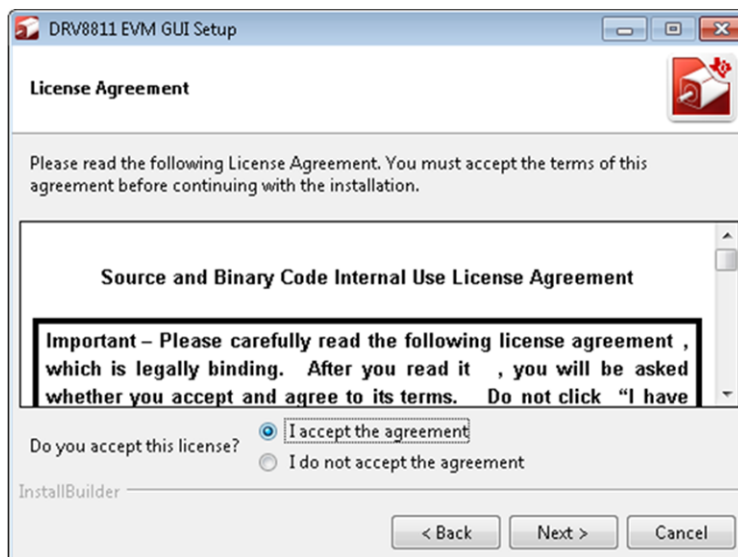

Figure 5. License Agreement

4. A screen as shown in [Figure 6](#) appears, displaying the license agreement of National Instruments. Please read through the agreement carefully and enable the "I Accept the License Agreement" radio button and press the **Next** button.

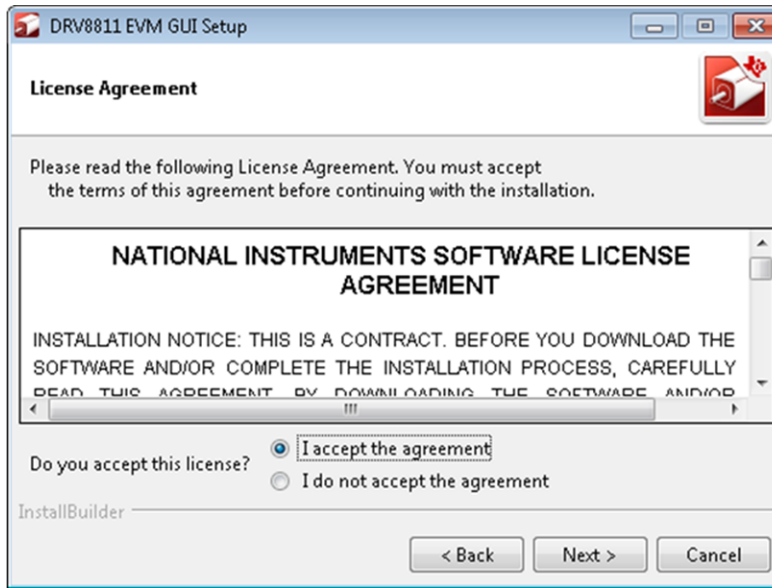

Figure 6. NI License Agreement

5. Set the default directory for the GUI Installation and click **Next**.

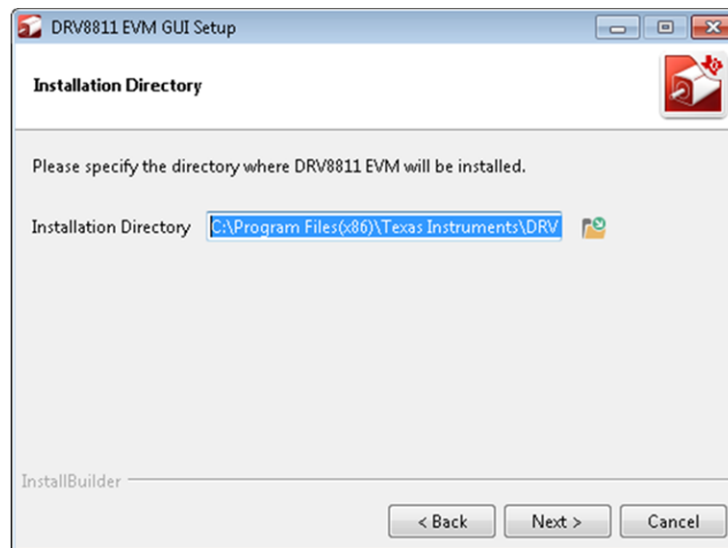

Figure 7. Installation Directory Screen

NOTE: It is highly recommended to keep the default values as provided in the installer.

6. A screen as shown in [Figure 8](#) appears. This screen is to select the components to install. Select the Components to Install and Click **Next** to continue installation. The LabVIEW RTE component checks out if the LabVIEW RTE 2014 is already installed on the PC.

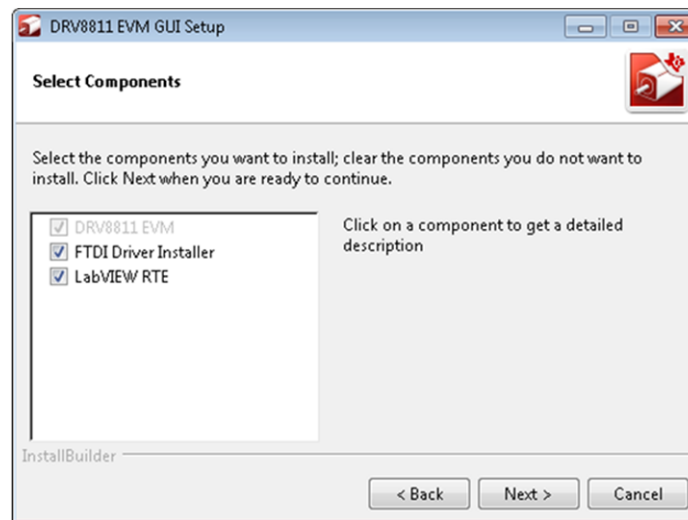

Figure 8. Component Selection

7. If LabVIEW RTE is selected as a component to install, a screen appears as shown in [Figure 9](#). Configure the proxy settings as required. This screen is to download the LabVIEW RTE 2014 from ni.com, Click **Next** to continue the installation.

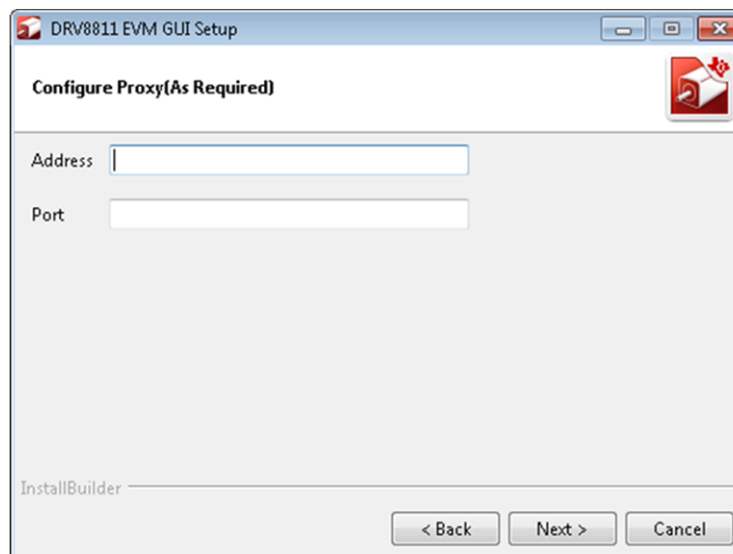

Figure 9. Configure Proxy

8. A screen as shown in [Figure 10](#) appears. Click **Next** to begin the installation.

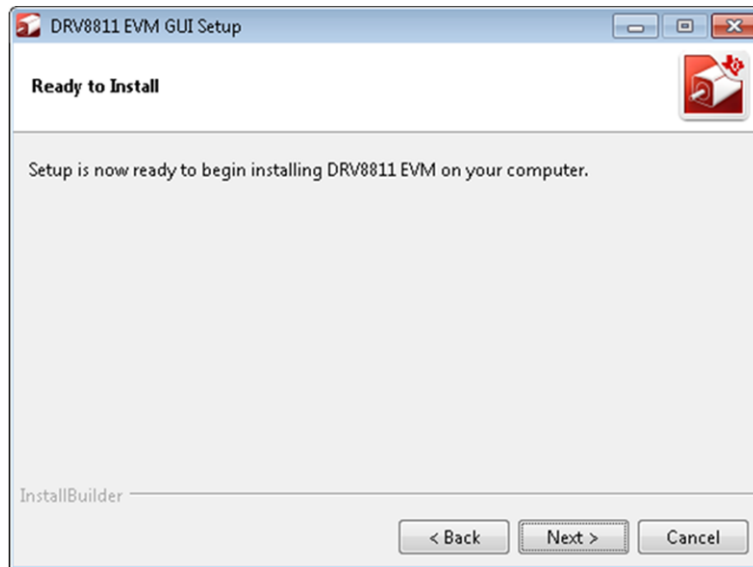

Figure 10. Ready to Install

9. If the LabVIEW RTE 2014 is selected as a component to install, LabVIEW RTE downloads and performs a silent mode installation.

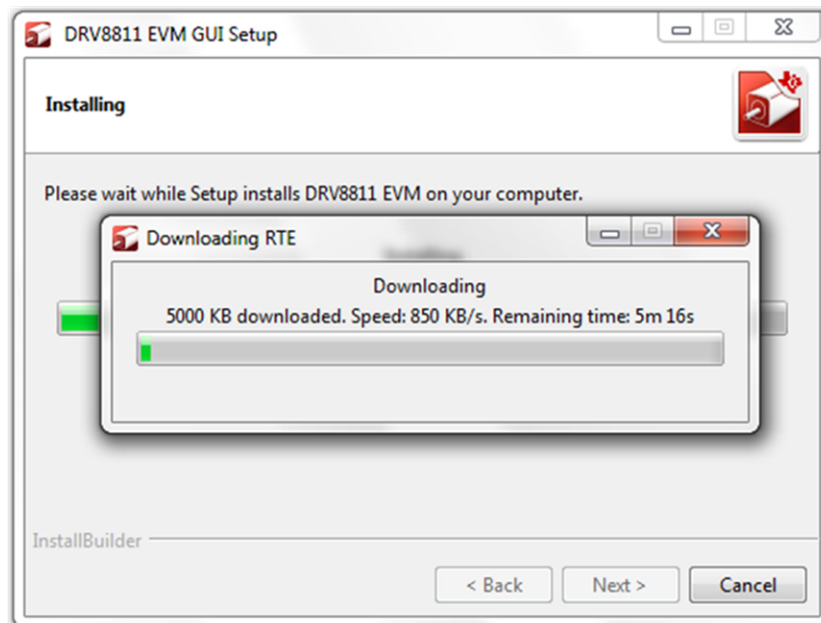

Figure 11. Downloading RTE

10. Once the download completes, LabVIEW begins with the self-extraction as shown in [Figure 12](#).

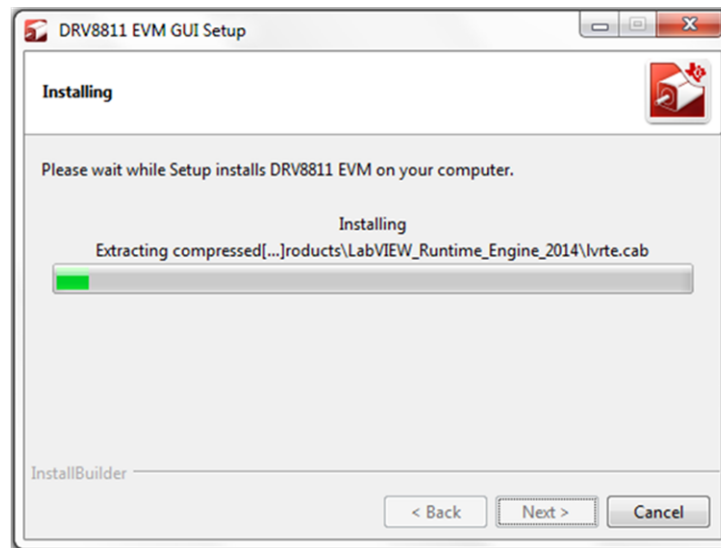

Figure 12. LabVIEW RTE Self Extraction

11. A Screen appears as shown in [Figure 13](#). It initializes the LabVIEW RTE Installation.

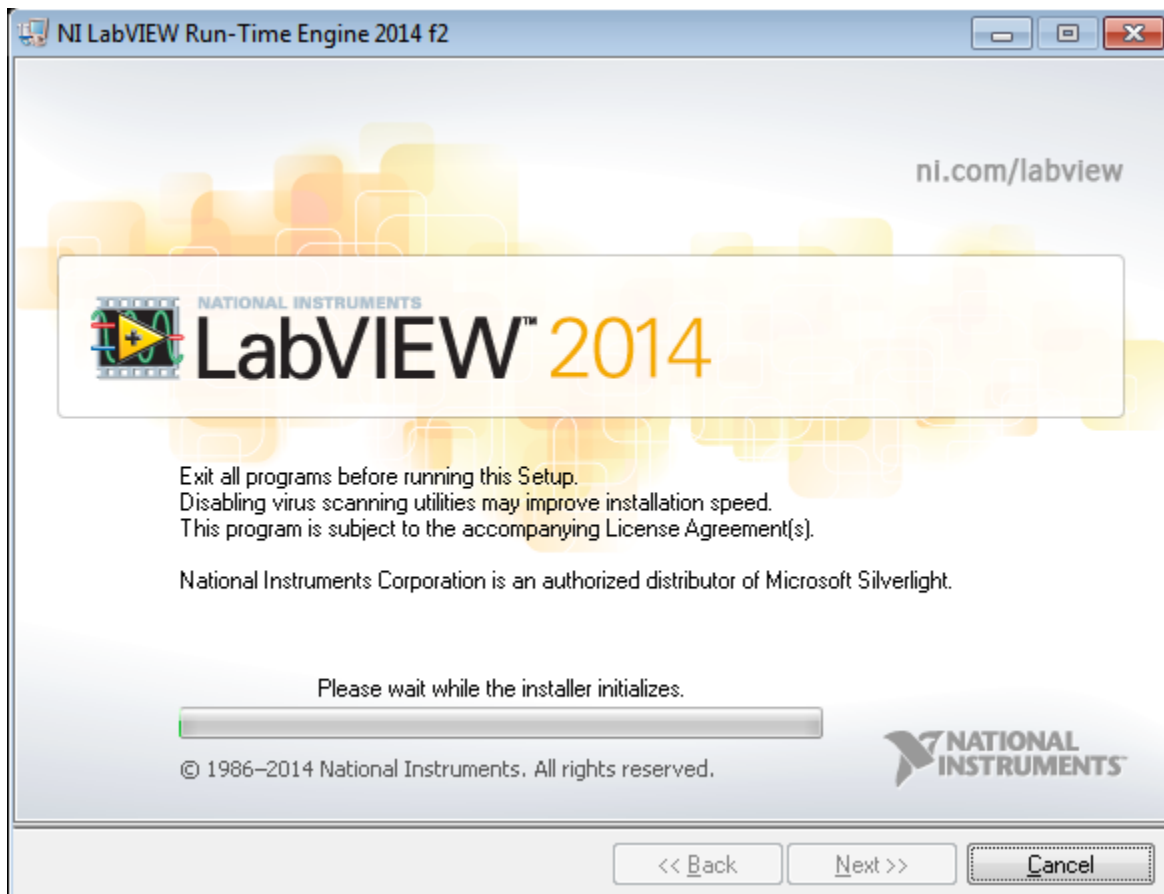

Figure 13. LabVIEW RTE Installation Initialization

12. A display as shown in [Figure 14](#) appears which indicates the progress of LabVIEW RTE installation.

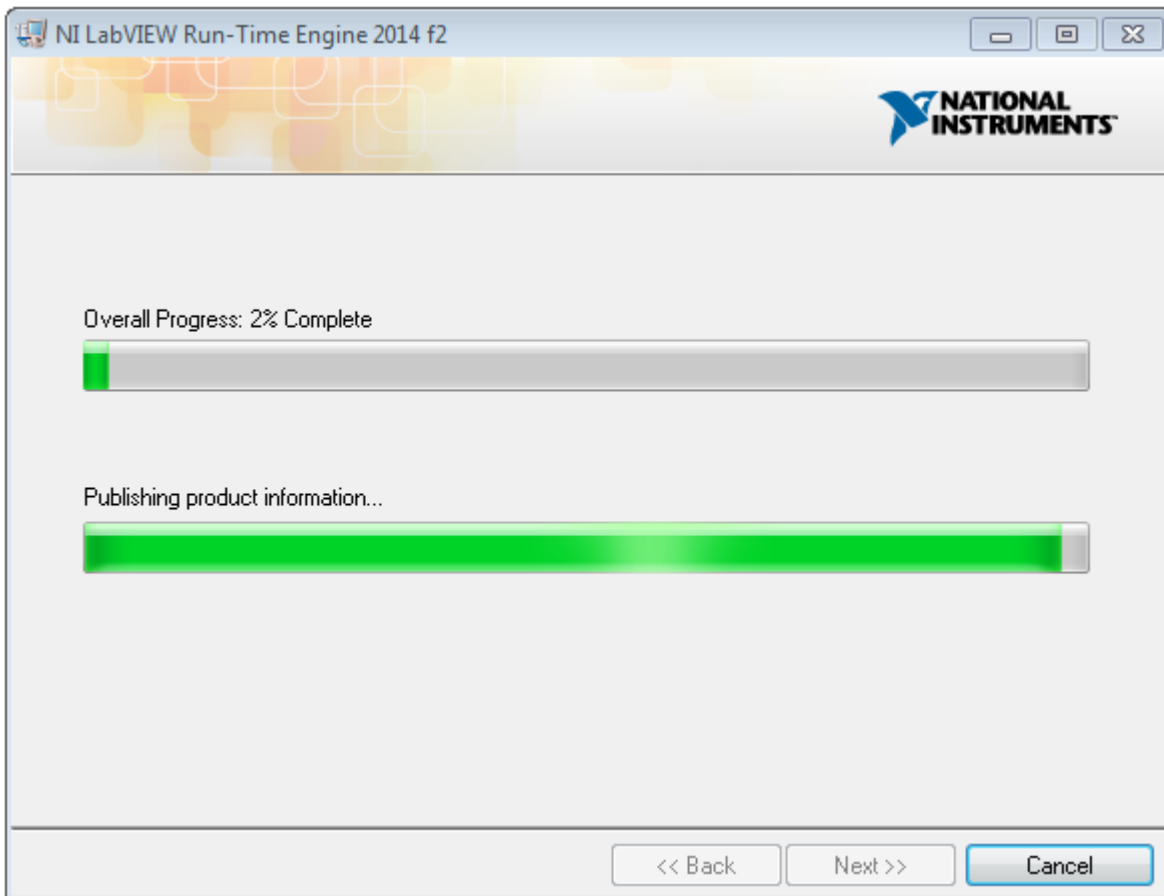

Figure 14. Installation of LabVIEW RTE in Progress

13. Once the LabVIEW RTE 2014 is installed, DRV 8811 EVM GUI component installs.
14. After DRV8811 Installation, FTDI Installation begins. A screen as shown in [Figure 15](#) appears, click **Extract** to proceed.

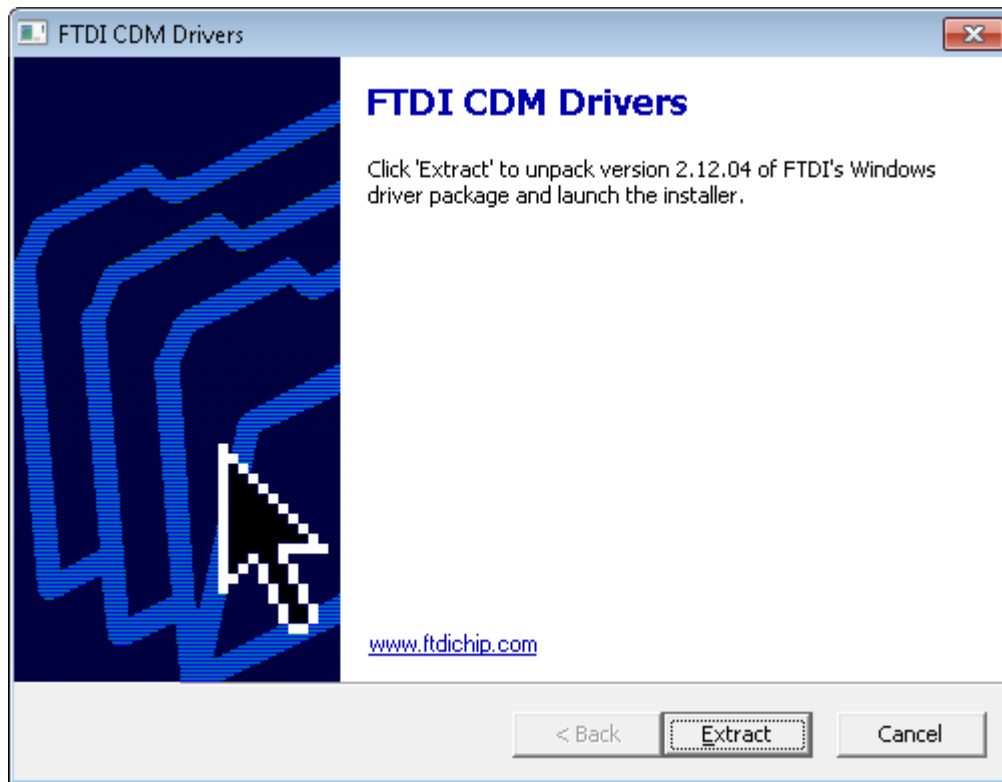

Figure 15. FTDI Installation Initialization

15. A screen as shown in Figure 16 appears, click **Next** to proceed.

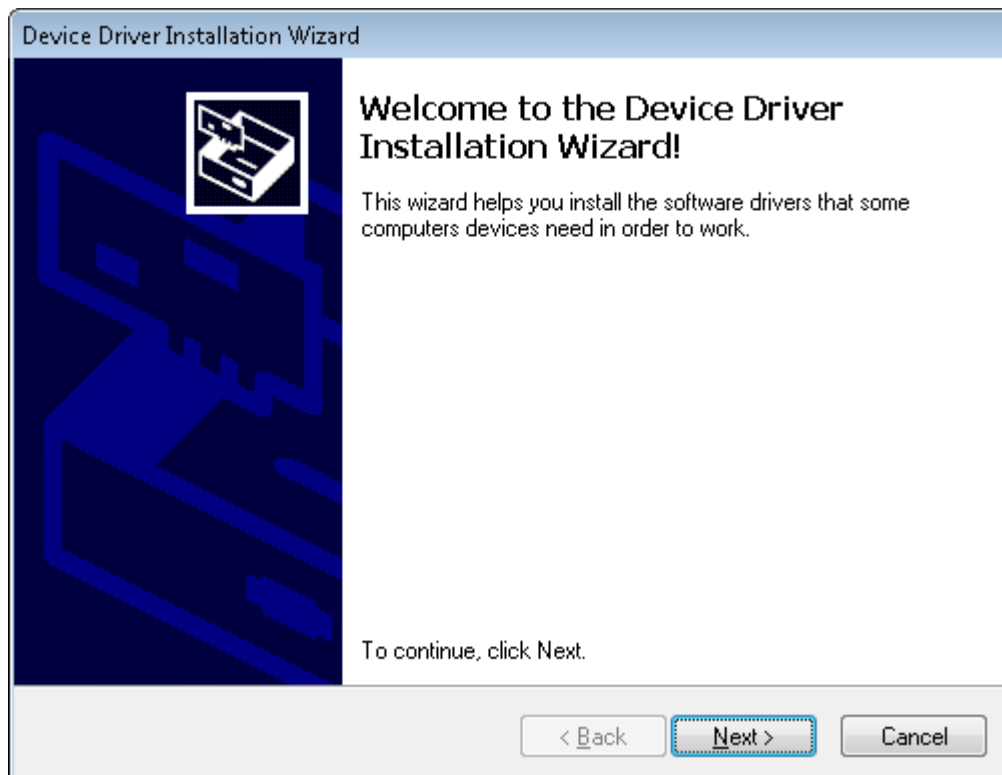

Figure 16. Driver Installation Wizard

16. The License Agreement appears on screen as shown in [Figure 17](#).
17. Read through the License Agreement carefully and enable the "I Accept this Agreement" radio button and Click on **Next**.

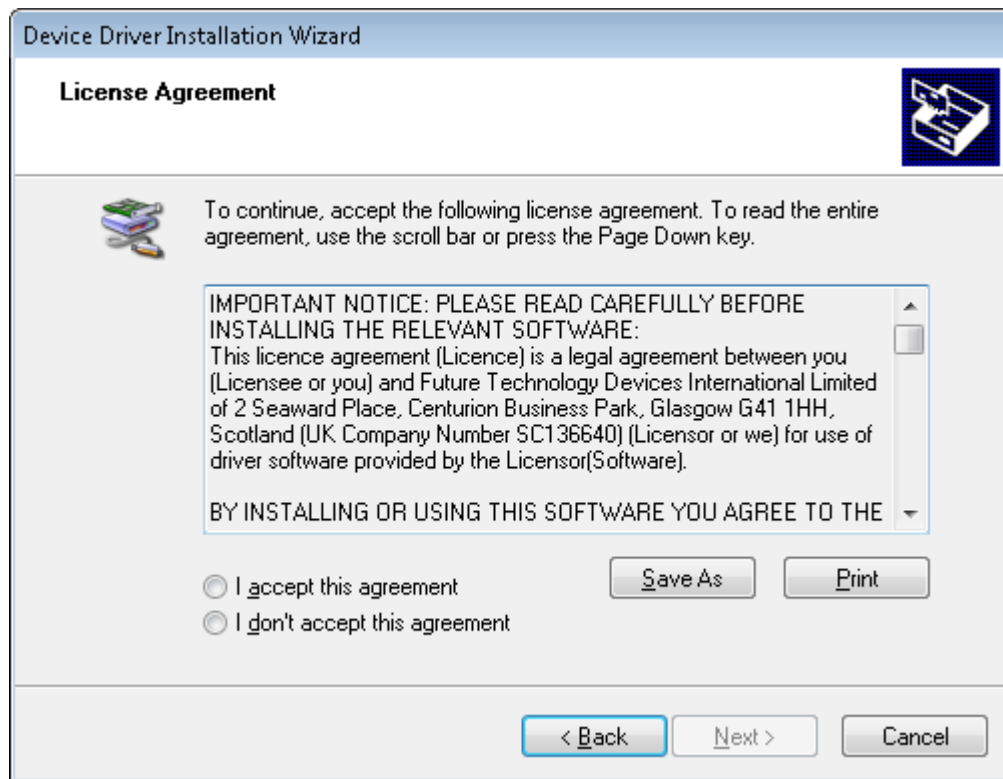

Figure 17. License Agreement for FTDI Driver

18. Click **Finish** to complete the Driver Installation.

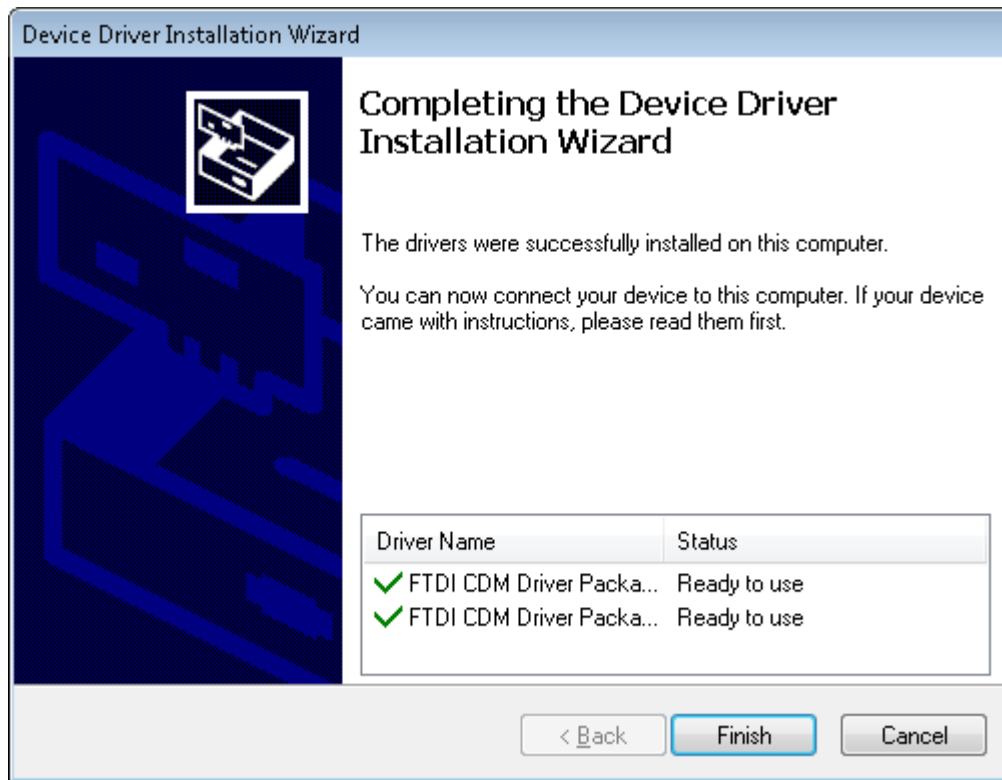

Figure 18. Driver Installation Completion

19. [Figure 19](#) appears denoting the completion of DRV8811 EVM GUI Installation. Click **Finish**.

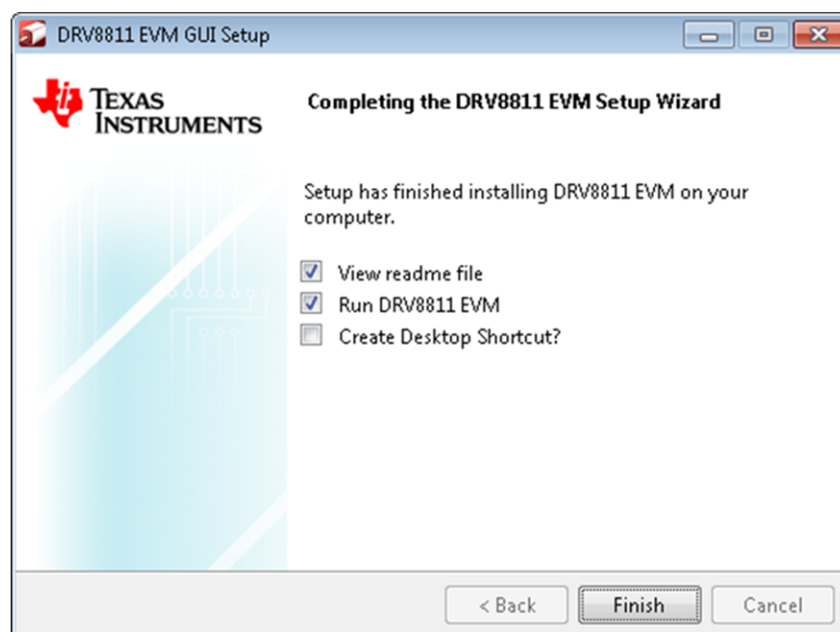

Figure 19. Installation Complete

20. A Readme window as shown in [Figure 20](#) appears displaying the link for LV 2014 RTE.

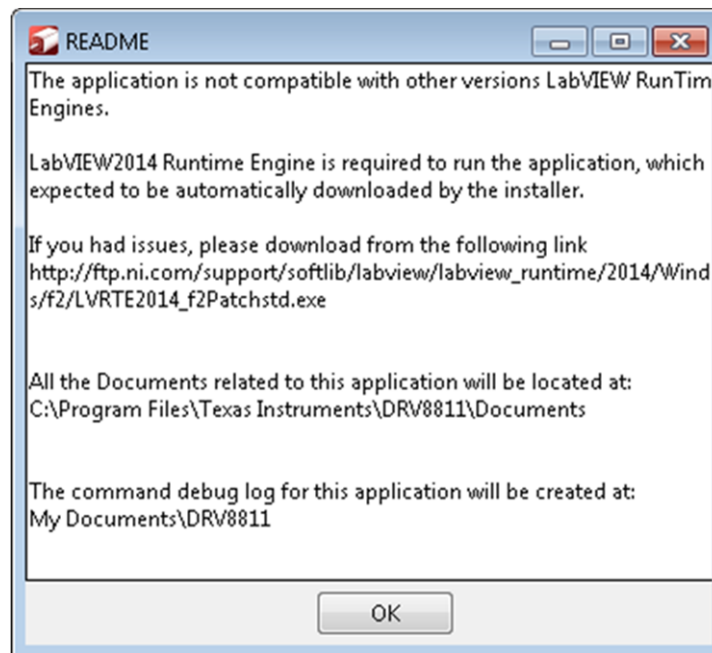

Figure 20. Readme Window

WARNING

The DRV8811 EVM GUI requires the LabVIEW Run-Time Engine 2014 to be installed before the GUI executes. Please note the application is not compatible with other versions of LabVIEW Runtime Engine.

You can download National Instruments LabVIEW Run-Time Engine 2014 from the below link:
[LabVIEW Run-Time Engine 2014](http://ftp.ni.com/support/softlib/labview/labview_runtime/2014/Windos/f2/LVRTE2014_f2Patchstd.exe)

NOTE: DRV8811 EVM GUI executable has been built in LabVIEW 2014 (32-bit) version, and it expects the LabVIEW Run-Time Engine version to be LabVIEW Run-Time Engine (32-bit version).

2.3 Running the Windows Application Software

To run the application, search for the desktop shortcut of the application or search for the DRV8811EVM GUI in your Programs or its installation directory.

3 Windows Application

The DRV8811 Windows Application is the software counterpart for the DRV8811 EVM. It is in charge of connecting to the MSP430 microcontroller via a USB connection which in turn selects the proper logic state for the DRV8811 control signals.

The graphical user interface (GUI) has been designed to allow for all of the DRV8811 device's functionality to be tested without having to intervene with the hardware, except for the proper configuration of jumpers when needed.

Figure 21 shows the GUI main screen. It contains menu items to configure and enable/disable the serial port, frames with GPIO control for the DRV8811 control signals, stepper motor control for start/stop and speed, and current/decay control through the MSP430 DACs.

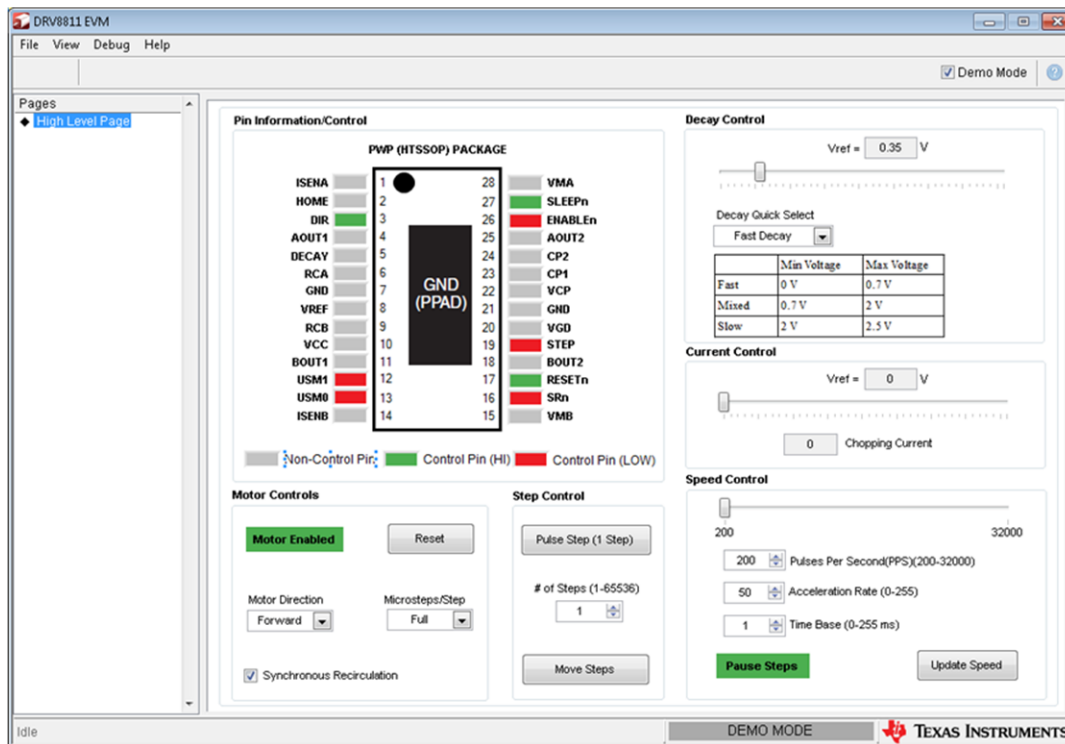

Figure 21. DRV8811EVM-001_R1p0.exe Main Screen

3.1 Menu

- File - The File menu contains the option Exit as shown in Figure 22 below.

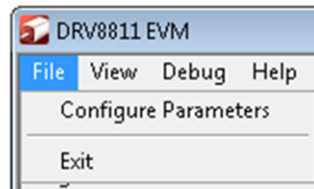

Figure 22. File Menu

- Debug - The Debug option can be used for the following operations.

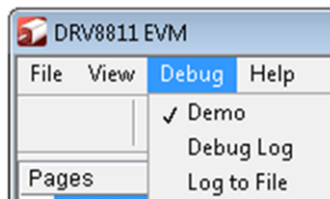

Figure 23. Debug Menu

- - Demo - By selecting the Demo in the submenu, the GUI runs in simulation mode, and by unselecting it, the GUI runs in connected mode.
 - Log to File - The log to file submenu is used to log the GUI activities to a log file that is specified.
 - Debug log - The Debug log option enables to log all the activities of the user. If that is not selected, only the high-level operations log.
- View - Select View-> Schematics->DRV8811 to view the GUIs schematics

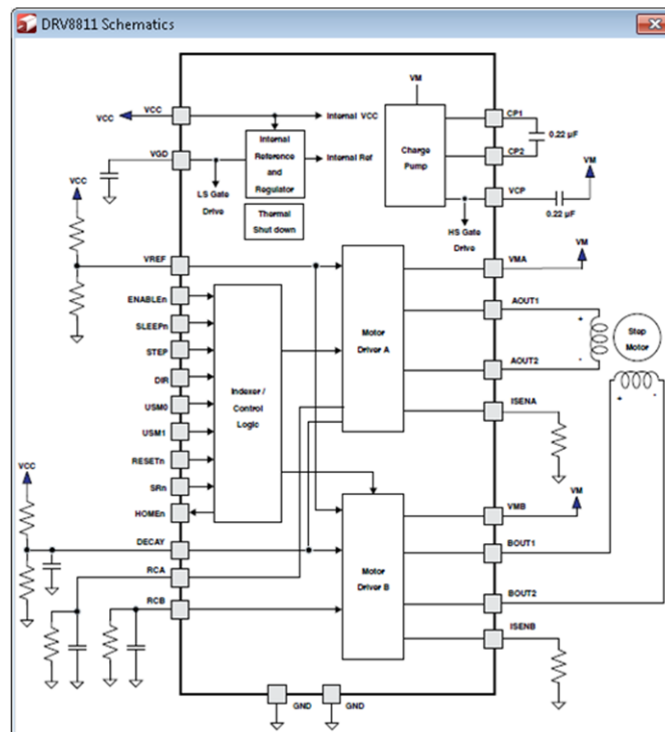

Figure 24. Schematic

- Help
 - Clicking the About in the Help Menu

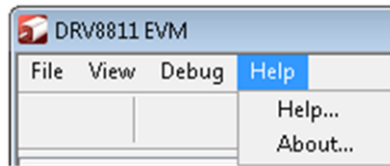

Figure 25. Help Menu

- The About Page provides the details like the Name of the GUI, GUI version, Supported OS and Copyright Information.



Figure 26. About Page

3.2 *DRV8811 GPIO Control Signals*

Once the application is communicating with the interface board, the control signals can be actuated by checking or un-checking check boxes on the Signals frame.

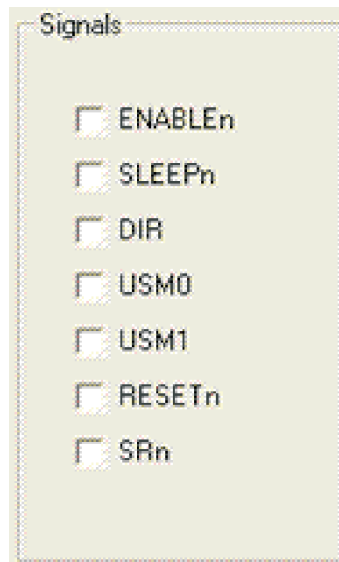

Figure 27. Signals Frame

A checked checkbox translates to a HI level on the respective control signal. A un-checked checkbox translates to a LO level on the respective control signal.

3.3 Updating DAC Output for Current Control (VREF/DECAY)

If the DRV8811 EVM has been configured to accept VREF analog voltages through the MSP430 microcontroller interface (JP1 is set to INT), then the slider bar on the Current Control frame can be used to set the VREF voltage.



Figure 28. Current Control Frame

The MSP430F1612 12-bit DAC channel 0 is connected to the DRV8811 VREF analog input. Changing the DAC digital value from 0 to 4095, changes the analog voltage at the VREF/DECAY pin from 0 V to 2.5 V respectively. See [Equation 1](#).

$$V_{REF} = DAC_VALUE \cdot \frac{2.5 V}{4095} \tag{1}$$

Where VREF is the output voltage and DAC_VALUE is a number from 0 to 4095.

3.4 Updating DAC Output for Decay Control (DECAY)

If the DRV8811 EVM has been configured to accept DECAY analog voltages through the MSP430 microcontroller interface (JP6 is set to INT), then the slider bar on the Current Control frame can be used to set the DECAY voltage.

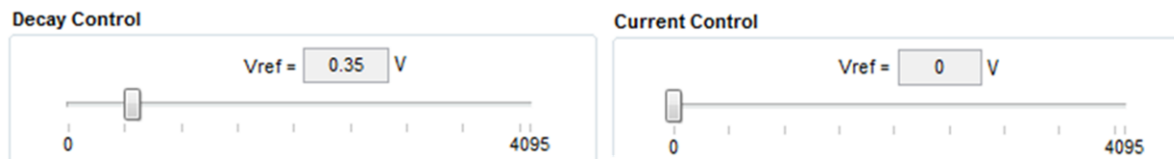
Figure 29. Current Control Frame

The MSP430F1612 12 bit DAC channel 1 is connected to the DRV8811 DECAY analog input. Changing the DAC digital value from 0 to 4095, changes the analog voltage at the DECAY pin from 0 V to 2.5 V respectively. See [Equation 2](#).

$$DECAY = DAC_VALUE \cdot \frac{2.5 V}{4095} \quad (2)$$

Where DECAY is the output voltage and DAC_VALUE is a number from 0 to 4095.

3.5 Operating the Stepper Motor

3.5.1 Turning the Stepper Motor

The Windows Application, in conjunction with the MSP430F1612 microcontroller, utilizes a series of timers to coordinate the rate of steps sent to the device. Once all the control signals are configured accordingly (ENABLE_n = LO, SLEEP_n = HI, RESET_n = HI; DIR, USM0 and USM1 can be HI or LO depending on preferred mode of operation; SR_n must be L, if external diodes are not populated), the motor is ready to be turned.

The DRV8811EVM-001 customer EVM allows for the possibility of coordinating step rates such that accelerating and decelerating profiles are achieved. Both acceleration and deceleration are controlled by the same parameters, acceleration rate and time base.

When the motor starts, it always starts at the slowed pulses per second (PPS) speed (62 pulses per second). The controller will accelerate the motor in order to reach the PPS speed. Acceleration rate is an 8-bit number (0 to 255) that gets added to the current PPS speed and time base is an 8-bit number (0 to 255) that specifies how many milliseconds will elapse from one speed increase to the next. Once the specified PPS speed has been achieved, the acceleration stops.

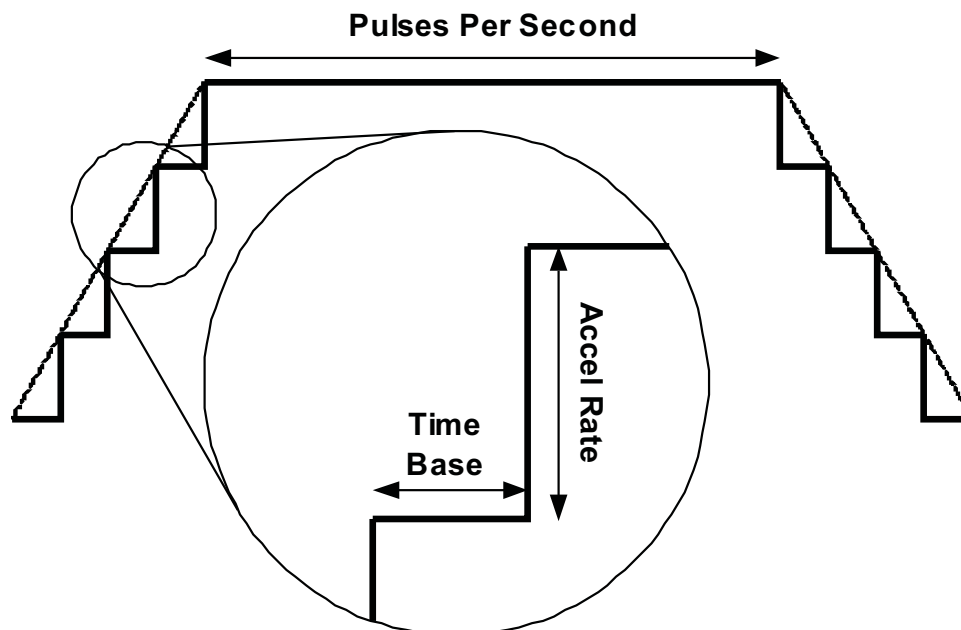
Figure 30. Step Rate

When the motor is commanded to stop, the inverse of the description above occurs.

The Windows Application frame to control speed, acceleration and deceleration, as well as motor start and stop, looks as portrayed in [Figure 31](#).

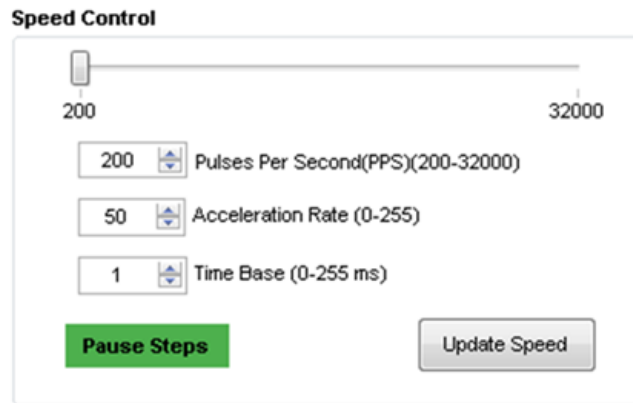

Figure 31. Speed Control Frame

Pressing the Start Steps button, will start the timer and pulses will be generated at the rate specified by the decimal number at the PPS text box. Once the Start Steps button is pressed it becomes the Stepping button. Press the Stepping button to stop the stepper motion.

When the motor is stepping, the Update Speed button becomes enabled. Speed can be updated by modifying the PPS text box and then pressing the Update Speed button. The Update Speed button is disabled every time the motor is not turning because the stepping has been halted by pressing the Stepping button.

3.5.2 Step by Step control

The Step Control frame has a series of tools to control the stepping of the motor on a predetermined number of steps fashion.

The Pulse Step button allows for a single step to be issued. At the same time, the STEP Control check box allows the control of the STEP signal in the same fashion that other GPIO signals on the Signals frame could be set and cleared. Checked stands for HI and unchecked for LO. Remember that a STEP takes place when STEP goes from LO to HI.



Figure 32. Step Control Frame

To move the motor a number of steps and then stop, fill the # of Steps text box with a decimal number from 0 to 65535 and the motor will move that number of steps at the speed specified on the PPS text box. No acceleration or deceleration takes place under this function.

IMPORTANT NOTICE AND DISCLAIMER

TI PROVIDES TECHNICAL AND RELIABILITY DATA (INCLUDING DATA SHEETS), DESIGN RESOURCES (INCLUDING REFERENCE DESIGNS), APPLICATION OR OTHER DESIGN ADVICE, WEB TOOLS, SAFETY INFORMATION, AND OTHER RESOURCES "AS IS" AND WITH ALL FAULTS, AND DISCLAIMS ALL WARRANTIES, EXPRESS AND IMPLIED, INCLUDING WITHOUT LIMITATION ANY IMPLIED WARRANTIES OF MERCHANTABILITY, FITNESS FOR A PARTICULAR PURPOSE OR NON-INFRINGEMENT OF THIRD PARTY INTELLECTUAL PROPERTY RIGHTS.

These resources are intended for skilled developers designing with TI products. You are solely responsible for (1) selecting the appropriate TI products for your application, (2) designing, validating and testing your application, and (3) ensuring your application meets applicable standards, and any other safety, security, regulatory or other requirements.

These resources are subject to change without notice. TI grants you permission to use these resources only for development of an application that uses the TI products described in the resource. Other reproduction and display of these resources is prohibited. No license is granted to any other TI intellectual property right or to any third party intellectual property right. TI disclaims responsibility for, and you will fully indemnify TI and its representatives against, any claims, damages, costs, losses, and liabilities arising out of your use of these resources.

TI's products are provided subject to [TI's Terms of Sale](#) or other applicable terms available either on ti.com or provided in conjunction with such TI products. TI's provision of these resources does not expand or otherwise alter TI's applicable warranties or warranty disclaimers for TI products.

TI objects to and rejects any additional or different terms you may have proposed.

Mailing Address: Texas Instruments, Post Office Box 655303, Dallas, Texas 75265
Copyright © 2022, Texas Instruments Incorporated